

NPS-AM-05-046



EXCERPT FROM THE PROCEEDINGS

OF THE
SECOND ANNUAL ACQUISITION
RESEARCH SYMPOSIUM

**NAVY ACQUISITION VIA LEASING: POLICY, POLITICS, AND
POLEMICS WITH THE MARITIME POSITIONED SHIPS**

Published: 1 May 2005

by

John Shank, Joe San Miguel and Don Summers

**2nd Annual Acquisition Research Symposium
of the Naval Postgraduate School:**

**Acquisition Research:
The Foundation for Innovation**

May 18-19, 2005

Approved for public release, distribution unlimited.

Prepared for: Naval Postgraduate School, Monterey, California 93943



ACQUISITION RESEARCH PROGRAM
GRADUATE SCHOOL OF BUSINESS & PUBLIC POLICY
NAVAL POSTGRADUATE SCHOOL

The research presented at the symposium was supported by the Acquisition Chair of the Graduate School of Business & Public Policy at the Naval Postgraduate School.

To request Defense Acquisition Research or to become a research sponsor, please contact:

NPS Acquisition Research Program
Attn: James B. Greene, RADM, USN, (Ret)
Acquisition Chair
Graduate School of Business and Public Policy
Naval Postgraduate School
555 Dyer Road, Room 332
Monterey, CA 93943-5103
Tel: (831) 656-2092
Fax: (831) 656-2253
E-mail: jbgreene@nps.edu

Copies of the Acquisition Sponsored Research Reports may be printed from our website www.acquisitionresearch.org

Conference Website:
www.researchsymposium.org



ACQUISITION RESEARCH PROGRAM
GRADUATE SCHOOL OF BUSINESS & PUBLIC POLICY
NAVAL POSTGRADUATE SCHOOL

Proceedings of the Annual Acquisition Research Program

The following article is taken as an excerpt from the proceedings of the annual Acquisition Research Program. This annual event showcases the research projects funded through the Acquisition Research Program at the Graduate School of Business and Public Policy at the Naval Postgraduate School. Featuring keynote speakers, plenary panels, multiple panel sessions, a student research poster show and social events, the Annual Acquisition Research Symposium offers a candid environment where high-ranking Department of Defense (DoD) officials, industry officials, accomplished faculty and military students are encouraged to collaborate on finding applicable solutions to the challenges facing acquisition policies and processes within the DoD today. By jointly and publicly questioning the norms of industry and academia, the resulting research benefits from myriad perspectives and collaborations which can identify better solutions and practices in acquisition, contract, financial, logistics and program management.

For further information regarding the Acquisition Research Program, electronic copies of additional research, or to learn more about becoming a sponsor, please visit our program website at:

www.acquisitionresearch.org

For further information on or to register for the next Acquisition Research Symposium during the third week of May, please visit our conference website at:

www.researchsymposium.org



THIS PAGE INTENTIONALLY LEFT BLANK



Navy Acquisition via Leasing: Policy, Politics, and Polemics with the Maritime Propositioned Ships

Presenter: John Shank, PhD, CPA, is Visiting Professor of Financial Management, Graduate School of Business & Public Policy, Naval Postgraduate School, and Emeritus Professor Dartmouth College Tuck Graduate School of Business. He received his PhD at The Ohio State University and has taught at Harvard, Ohio State, Babson, and Dartmouth Business Schools. He has consulted and taught executive programs for many companies. His interests are strategic cost management, financial controls, and finance.

Presenter: Joe San Miguel, PhD, CPA, is Professor of Financial Management, Graduate School of Business & Public Policy, Naval Postgraduate School. He received his PhD at the University of Texas at Austin. He has taught at NYU, Harvard, Stanford, and Dartmouth and consulted and taught executive programs for numerous companies. His interests are strategic resource management, strategic control, and corporate financial reporting.

Presenter: Don Summers, LtCol, USMC (Ret.), CMA, is Lecturer in Financial Management, Graduate School of Business & Public Policy, Naval Postgraduate School. He received an MS from the Naval Postgraduate School. Before retiring from the USMC, he was Program Budget Coordinator for the Chief Financial Officer, Headquarters Marine Corps. He has consulted for numerous companies and has been employed as a financial analyst. His interests are financial & managerial accounting, federal budgeting and armed forces comptrollership.

Abstract

In recent months, leasing has been prominent in the press in connection with the Air Force's ill-fated attempt to obtain the use of Boeing re-fueling tankers without buying them. Gone from memory is the early 1980's controversial Navy leasing program of Maritime Propositioned Ships that had a different result. This paper presents an analysis of the various issues and parties to the very creative and innovative financing on behalf of the Navy's Military Sealift Command. Still in existence today, the 1983 contracts for thirteen TAKX ships were valued at approximately \$2.6 billion. While the decision is often framed as a "lease versus purchase" choice, the facts indicate that the option to purchase was not seen as viable at the time. In hindsight, the TAKX leasing program was successful and cost effective, despite the whirlwind of political commentary and intrigue and the dueling quantitative analyses surrounding it. However, as an unintended (or, perhaps, intended) consequence, laws and policies have since been changed so that leasing is no longer viable for financing military assets. The case presented here considers altering existing laws and regulations to once again permit leasing of military resources.

Keywords: Leasing, Tankers, Financial Analysis, Present Value, Acquisition Alternatives



Introduction

On January 25 and February 7, 2005, *The Wall Street Journal* confirmed a widely reported major shift in Department of Defense (DoD) weapons acquisition policy over the next decade.¹ The articles cite retired VADM Arthur Cebrowski, head of the Pentagon's Office of Force Transformation, who sees an increasingly significant shift away from capital-intensive weapons towards the more labor-intensive systems used in guerilla wars.

Notwithstanding this transformative agenda, the Navy's FY2006/FY2007 President's Budget still makes a strong case for a steadily growing capital investment budget between 2005 and 2011. The budget proposal submitted on February 23, 2005, by RADM Bruce Engelhardt, Director of the Office of Budget in the Office of the Assistant Secretary of the Navy (Financial Management and Controller), shows proposed growth in annual weapons investments from \$26 billion in 2004 to \$42 billion in 2011.² The key components of this budget include the new Joint Strike Fighters, DD(X) destroyers, Virginia-class nuclear submarines, and MMA aircraft to replace the aging P3 Fleet, among many other programs. Not mentioned explicitly in RADM Engelhardt's report is the question of how to replace thirteen currently leased Maritime Prepositioned Ships (MPS) which support the readiness of three Marine Expeditionary Brigades. The use of these ships was arranged in the early 1980's through 25-year leases (five renewable periods of five years each), which will expire between 2009 and 2011.

This paper reviews the history of the MPS program to try to assess the lessons for current Navy acquisition policy. In 2005, we believe there is a strong disposition against leasing as a financing strategy for the US military. As just one piece of evidence, consider the recent firestorm of criticism which met the Air Force's attempt in 2002 to lease, instead of buy, replacements for 100 aging KC135E refueling tankers.³ We believe a dispassionate evaluation of the MPS history can contribute significantly to an assessment of the efficacy of leasing as a component of future acquisition policy.

Some History on the Policy Perspective

The Navy has a long history of leasing ships to augment military capability in times of war.⁴ Over 450 supply ships, using merchant marine crews, were leased and deployed during World War II. During the Korean War, over 200 leased ships were deployed. More recently, during the Vietnam War in 1972, the Navy entered into a lease agreement to charter nine new T-2 fuel tankers to replace 14 worn out WWII-vintage tankers. Originally, appropriated funds were earmarked to build these new tankers. However, when acquisition proved infeasible because of budget limitations, the DoD opted to approve a long-term lease instead. There is no indication that this transaction encountered substantial resistance within the military or in Congress.

¹ Jaffe, G. & Karp, J. (2005, January 25). Military faces even deeper cuts. *Wall Street Journal*. See also Pasztor, A. (2005, February 7). Army program could boost defense spending. *Wall Street Journal*.

² Engelhardt, B. RADM USN. (2005, February 23). *Department of the Navy FY2006/FY2007 President's Budget*. Washington DC: Office of Budget, Office of the Assistant Secretary of the Navy (Financial Management and Comptroller).

³ Furber, D. & Jaeger, H. (2004, June). An examination of the United States Air Force proposed lease of refueling tankers. [MBA Professional Report]. Monterey, CA: Naval Postgraduate School.

⁴ Peters, M. A. (1979). Is leasing by the Federal Government a good thing for the American taxpayer? The GAO tanker report—A case study. [PhD Dissertation]. San Francisco: Golden Gate University.



The Navy also has a long history of leasing several categories of what might be called “off the shelf” auxiliary support equipment. For example, even up to the present time, leasing (rather than buying) is the financing mechanism of choice for such items as power storage batteries on nuclear submarines, reduction gears on surface warfare ships, and medical equipment in Navy hospitals. Again, none of these policy choices seem to engender significant political controversy, even in peace time.

In spite of this historical context, the MPS program did generate substantial controversy and political conflict between 1981 and 1983. It was the first peace-time attempt to use leasing to acquire a multi-billion dollar pool of specially designed military equipment—thirteen ships, each valued at more than \$182 million. But, the program was not originally intended to bypass normal acquisition and appropriation review channels.

The MPS program grew out of the successful “Prepositioned Force” (deployed in the late 1970’s at Diego Garcia in the Indian Ocean) which was made up of older cargo vessels. Between 1977 and 1979, this idea was expanded to a proposed fleet of 13 specially designed cargo ships with sufficient Lift-off/Lift-on (LO-LO) and Roll-on/Roll-off (RO-RO) capabilities to support the equipment and supplies necessary for a rapid deployment of three Marine Expeditionary Brigades for thirty days of combat. Depending on the technical characteristics, three or four ships were required for each Brigade. This so-called TAKX Program was officially authorized by the Naval Sea Systems Command (NAVSEA) in 1979.

Between 1979 and 1981, NAVSEA struggled to find a way to fit TAKX into the Navy’s procurement backlog. The “good news” was that 1981 saw the beginnings of President Reagan’s program to vigorously rebuild US military forces, including the vision of a “600-ship Navy” and increasing amphibious capabilities for the marines. The “bad news” was that so many programs involving high-priority combat systems were simultaneously under consideration that requesting Congress to appropriate funds for non-combat support ships was not seen as justifiable.

Yet, the Navy and the Pentagon felt strongly that the TAKX Program was indeed a high priority. Updating the Military Sealift Command (MSC) was an essential component of the overall expansion program dictated by the threat of Soviet military power in the post-Vietnam stage of the Cold War. MSC operates a Combat Prepositioned Force for the Marine Corps and a Logistics Prepositioned Force for the Navy, Air Force, and Defense Logistics Agency (DLA), as well as the Maritime Prepositioned Ships; but only the MPS Program’s ships are leased.

It is worth repeating, in this context, that the MPS leases were not seen primarily as a financing device for the TAKX Program. The choice was not seen as “lease versus purchase,” but rather as “lease versus do-without.” As we move on to analyze the MPS Program in more detail, it is important to keep in mind this distinction as to whether leasing is a financing option for assets whose acquisition has already been approved, or a mechanism to avoid deleting assets from the overall acquisition program.

A Synopsis of the Policy Dilemma

There is no question that the legislative, regulatory, and political context in 2005 is structured such that leasing is virtually infeasible for billion-dollar military programs. If leasing is, in fact, a “bad idea” for US military acquisitions, the current structure is appropriate. But, *is* leasing a “bad idea”?



The MPS Program, in retrospect, is seen as a significant success. In 2004, Bailey & Escoe and Haslam, et al. documented many important uses of the ships between 1985 and 2005, including their crucial role in Operation Desert Storm in 1991.⁵ Without the leasing option, the Navy would not have been able to acquire the TAKX ships. Thus, leasing can be seen as one of the crucial elements in the success of Desert Storm.

Even if one were to grant the proposition that leasing is only an acceptable extension of acquisition policy under the exigencies of wartime, it is possible to counter that the events of September 11, 2001, mean the US is “at war,” and will be for the foreseeable future. In that context, one can question whether it is appropriate to take leasing off the table in 2005 as an option to finance the on-going “Global War on Terror (GWOT).” Should not leasing be considered very carefully, prospectively, as a mechanism to augment defense capabilities without forcing cut backs in acquisition planning for other programs?

That is, should not leasing be carefully evaluated, on its merits, as a way to expand defense capabilities beyond what can be paid for in the context of the year-by-year acquisition process?

The Structure of the MPS Deal

In October 1981, NAVSEA issued the Request for Proposal (RFP) which sought bids to supply thirteen ships for the MPS Program. This was the largest single ship financing program ever undertaken by the Navy, representing \$2.65 billion. Because of the tremendous scope and complexity of this program, the Navy also issued a RFP for consulting services. Argent Group, Ltd. (AGL), a small investment banking firm specializing in leveraged-lease financing, was engaged.

Although the ships involved thirteen separate contracts, the structure of each contract was the same and all were implemented at the same time. The Deal consisted of six principal participants: the Owner/Lessor, Federal Financing Bank, Shipyard, Contractor, Operator (MSC), and the Navy.

Figure 1 summarizes the legal relationships in the Deal, and Figure 2 summarizes the financial flows and business relationships.

Figure 1. The Legal Relationships

<u>Contractor</u> <u>Special Purpose Entity</u>	<u>Award</u>	<u>Private Investor/Owner</u>	<u>Shipyard</u>
General Dynamics Corp.	5 TAKX Ships	Salomon Brothers, Inc.	General Dynamics Corp.
Maersk Line, Limited	5 TAKX Ships	Morgan Guaranty Trust Co. of NY	Bethlehem Steel Corp.
Waterman Steamship Corp.	3 TAKX Ships	Citibank, N.A., and Manufacturers Hanover Leasing Corporation, acting jointly	National Steel and Shipbuilding Co.

⁵ Bailey, J. & Escoe, M. (2004, December). Innovations in funding the maritime prepositioning ships program—A case analysis of the how and why the lease option was successful. [MBA Professional Report] Monterey, CA: Naval Postgraduate School. See also: Haslam, P., Koenig, R. & Mitchell, S. (2004, December). An examination of the United States Navy leasing: Lessons from the MPS/T-5 experience. [MBA Professional Report] Monterey, CA: Naval Postgraduate School.



Figure 2. Business Relationships During Construction and Subsequently during Operation (See numerical key below)

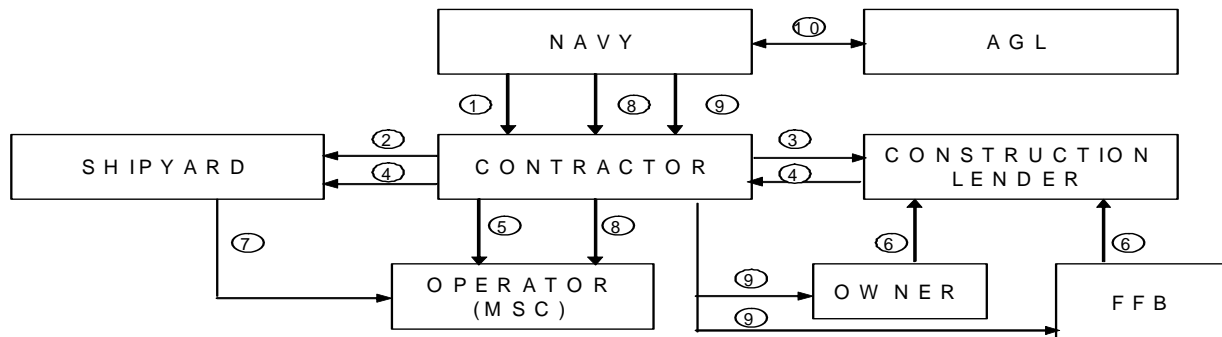

Construction Period

- (1) Agreement to Charter, after construction
- (2) Construction Contract
- (3) Construction Loan Agreement
- (4) Construction Progress Payments
- (5) Construction Supervision Payments

Operating Period

- (6) Repay Construction Loans (30% Owner/70% FFB)
- (7) Delivery, subject to terms of construction contract
- (8) Operating Hire Payments
- (9) Capital Hire Payments
- (10) Ongoing Consulting Fees

There were four elements of the Deal for each ship: construction, financing, delivery and time charter arrangements. Following is a discussion of each element.

Construction:

- The Contractor negotiated a fixed-price construction contract with the shipyard and provided progress payments during construction.
- The Contractor arranged interim loans to finance the construction. The Contractor assumed all risk associated with the loans until an acceptable ship was delivered to the Navy.
- The Contractor was responsible for supervising the construction to ensure the ship was completed according to the specifications and plans, including the Navy’s operational and technical requirements. The Contractor paid a supervisory fee to the Operator (MSC) to supervise construction.
- The Navy retained the right to inspect the construction, but it could not deal directly with the shipyard, nor did it have any supervisory obligations, unilateral design change rights, or liability to the shipyard in the event of cost overruns.



- The ships were constructed using current commercial specifications, known as American Bureau of Shipping (ABS) standards.

Financing:

- Prior to delivery, the Contractor arranged permanent financing for the ship, consisting of equity from private investors (30%) and debt from the FFB (70%).
- The private investors assumed ownership upon delivery of the ship. They were eligible, under existing legislation, to receive accelerated depreciation tax benefits associated with ownership.
- The debt was in the form of 25-year bonds purchased by the FFB which held a mortgage on each ship to secure the debt.

Delivery:

- When the shipyard completed the vessel, it was delivered to the owner who simultaneously delivered it to the Contractor under a “bareboat charter.” The proceeds of the debt and equity financing were used to pay off the interim construction loans.
- The Contractor turned the ship over to the MSC under an operating contract. The ship was chartered to the Navy under the Time Charter provisions.
- Upon delivery, the construction cost of each ship was adjusted to reflect actual interest rates paid during construction on the interim construction loans.

Time Charter:

- The Navy began its charter hire payments (comprising both the capital hire and operating hire payments) upon delivery and acceptance of each ship.
- The semi-annual capital hire payments were made on a “hell or high water” basis. Upon delivery, the capital hire rates were adjusted to reflect the actual debt and equity financing rates. Once adjusted, the Navy’s capital hire rates were fixed for the entire charter period.
- Each Time Charter was an initial five-year contract with four renewal periods, for a total of 25 years. If the Navy failed to exercise renewal options or terminated for convenience after the initial period, the vessel would be sold, and the Navy would pay the difference between the selling price and the contractual termination value—which was designed to repay the debt and give the owners their agreed-upon return on investment. However, the Navy held an option to purchase the ships at the higher of the termination fee or ship’s market value.
- The operating hire component was paid to the Contractor, who in turn paid the MSC. It includes operating expenses and a margin as agreed to in the contract. The Contractor assumed the risk for all off-hire provisions and ship non-performance. The Time Charter also contained inflation provisions to compensate for increases in crew wages, stores and subsistence, maintenance, and insurance. Provision for loss of the ship was also included.

The Politics and Polemics of the MPS Deal

From its formal authorization by the Secretary of Defense in August 1979, to its approval by the Office of Management and Budget (OMB) in December 1981 (to be included in the 1983 Budget), the TAKX Program moved along without any significant challenges or controversy. It was first authorized by Congress in September 1980. The tax aspects of the lease contract were reviewed with the Internal Revenue Service (IRS) in November 1981. The Navy



commissioned a study by the international CPA firm Coopers and Lybrand (C&L) in February 1982. C&L concluded that the lease agreement was substantially cheaper for the government than purchasing the ships, when considering the net present value of all payments over the term of the lease, based on existing laws and tax regulations. In response to the RFP, several bids were received in March 1982. In April 1982, AGL began its work to help the Navy zero-in on the best bids and begin signing contracts.

However, as the cherry trees started to bloom in Washington that spring, Congressional interest in the TAKX Program also began to blossom. The honeymoon was over. In early May, the Secretary of the Navy, John F. Lehman, received inquiries from Congress as to whether the TAKX Program complied with federal standards in support of the American Merchant Marine and the American shipbuilding industry. Senator Howard Metzenbaum of Ohio was concerned that no shipbuilding involved his state. Secretary Lehman responded by letter in late May to the House Appropriations Committee, assuring them that all federal standards were being fully met.

A letter from the Chairman of the Defense Subcommittee of the House Appropriations Committee to Secretary Lehman, dated July 20, 1982, noted that the 1980 authorization by Congress presumed procurement of the MPS through normal appropriations channels. Congressman Joseph Addabbo directed the Navy not to enter into any contractual agreements until a Surveys and Investigations (S&I) report could be commissioned and completed. Secretary Lehman agreed to this request on July 30.

On August 17, the Senate Armed Forces Committee and the House Appropriations Committee notified the Navy that they were undertaking a review of the TAKX lease contracts under Section 303 of the FY1983 Authorization Act. Section 303 required a 30-day review period for Congress to determine that leasing was preferable to purchasing through normal appropriations channels before lease contracts could be signed.

By mid-August, AGL's own financial analysis of the lease program confirmed C&L's favorable conclusion. Based on a firm belief that the Deal was "cost-effective," the Navy awarded contracts for 6 TAKX ships on August 17, 1982, with the option for 7 additional ships during the 1983 fiscal year. These contracts were publicly announced on August 18. The next day, AGL released its conclusion that the net present value of each lease was \$140.6 million versus a net purchase cost of \$184.0 million per ship.

One major component of the attractiveness of the leases to private owners was tax savings from the use of accelerated depreciation. Under applicable laws in 1981, the owners of the TAKX ships could use a five-year life and the Accelerated Cost Recovery System (ACRS) rates. In 1982, there was significant public indignation about the drain on the US Treasury from these generous tax "write offs" (which Congress had enacted in 1981) for wealthy private investors. Many in Congress were sympathetic to this criticism of "special tax deals." In 1982, Congress passed the Tax Equity and Fiscal Responsibility Act (TEFRA), which substantially eliminated special tax benefits due to short tax lives and accelerated depreciation for assets used by non-profit entities. The TEFRA provision would have reduced the present value of the depreciation tax benefits on each TAKX ship by \$8.3 million, but TEFRA did not become effective until December 1983, by which time all the TAKX ships were already under construction.

Another component of the tax incentive to the lessor/owners was the Investment Tax Credit (ITC). If the leases were deemed "qualified" for ITC under the tax laws, ten percent of the cost of the ships was available to the owner as an immediate tax credit upon purchase of the ship. Both C&L and AGL argued that the leases would qualify for ITC. However, many observers questioned whether the credit should be available to the owners since the Navy retained "significant risks of ownership." The ITC was also seen as an unwarranted drain on the



US Treasury for the benefit of “special interest” wealthy investors. A ruling by the IRS on December 10, 1984, did, in fact, disallow the ITC for the TAKX ships. This ruling resulted in an upward adjustment of the annual lease payment to make up for the lost tax benefits to the owners. But, by December of 1984, the TAKX Program was a “done deal.”

On September 1, 1982, the S&I Report commissioned by Congress to review the MPS was released. It confirmed the cost advantage of leasing over purchasing for any applicable discount rate up to 19%. The report also confirmed the appropriateness of the 10% interest rate used in the AGL analysis under applicable OMB and DoD regulations.

The S&I Report did, however, raise a major red flag about the TAKX Program concerning encumbrances to the Navy Industrial Fund (NIF). The TAKX leases presumed that, year by year, only the annual lease payments would be charged against the NIF. The S&I Report noted, instead, that the present value of all future lease commitments and potential termination penalties would need to be encumbered in the NIF as a matter of law. This could be a major problem, since the full present value of over \$2.6 billion was more than the current unencumbered balance of about \$2.2 billion in the NIF.

In spite of this potential concern, both the Senate Armed Forces Committee and the House Appropriations Defense Subcommittee notified the Navy on September 16 (one day before their 30-day deadline) that the provisions of Article 303 of the 1983 Authorization Act were successfully met, and the lease contracts could proceed. So far, so good.

But, on September 17, 1982, the House Subcommittee on Readiness held a hearing on the TAKX Program. Chairman Dan Daniel expressed serious dissatisfaction with the leases, which he said inappropriately circumvented the Congressional authorization/appropriations process and thus impeded effective legislative review. He noted that the leases obligated the Government to 25 years of lease payments or to substantial termination penalties if the leases were canceled. He concluded that although the TAKX leases were already approved, he would do his utmost to see that appropriate action was taken to prevent a recurrence of this “side-stepping” of Congressional authority.

On December 2, 1982, the Comptroller of the Navy requested the US General Accounting Office (GAO) to clarify the issue regarding the encumbrance to the NIF. The GAO report was released on January 28, 1983. It said that the Navy must encumber the NIF for five years of lease payments (the initial guarantee period) plus the full termination payments that would be due in five years if the leases were cancelled. This requirement ran the very real risk of overencumbering the NIF. That would be a very serious violation of the Anti-Deficiency Act. The GAO posed no legal objection to the Deal, as long as the NIF had sufficient available unencumbered funds. The GAO suggested that the Navy seek explicit legislative relief to cover this issue.

The Supplemental Appropriations Act of 1983 (P.L. 95-63) did grant the Navy the authority to proceed with the TAKX Program in the absence of an appropriation covering the total termination liability under the leases. This legislation was a necessary stop gap action to keep the program on track. But it was not a clear, definite response to the NIF encumbrance issue.

On February 15, 1983, the Joint Committee on Taxation (JCT) issued a lengthy and comprehensive analysis of the TAKX leases which contradicted the AGL conclusion that leasing was more cost effective than purchasing. The JCT’s overriding premise was very simple: leasing can only be cheaper if the borrowing cost of the lessor is lower than the borrowing cost of the lessee. Since the Federal Government has the lowest borrowing cost in the world, the TAKX leases involve compensating the lessor for financing costs that must be higher than the



Government would have borne to borrow money and buy the ships. The JCT report also challenged many of the assumptions and calculations in the AGL report with detailed alternative calculations. The JCT concluded that leasing each ship was \$9.7 million more expensive than purchasing. The difference between the AGL and JCT positions will be summarized in a later section of this paper. Suffice it to say here; as the TAKX Program was moving ahead, the release of a report by a respected Congressional unit that was negative toward the cost-benefit argument presented by the Navy was very embarrassing.

On February 23, 1983, Senator Metzenbaum wrote to the Secretary of the Treasury to describe parts of the TAKX leases as an “outrageous” subsidization by the Navy of a legal case against the IRS. The TAKX leases included a provision that the lease rates would increase if the IRS were to reject any of the tax benefits assumed in the contract. Senator Metzenbaum argued, very publicly, that this amounted to the Navy paying the legal costs of investors seeking to overrule the IRS.

Interestingly, an article in *The Washington Post* on February 25, 1983, reiterated Senator Metzenbaum’s charges under a rather inflammatory headline: “Navy Promises Suppliers Tax Breaks.”⁶ The Navy’s response was that the contracts constituted very normal business practice regarding issues of the tax impact of leveraged-lease deals. *The Post* likened these “tax breaks” to the buying and selling of tax advantages by wealthy investors that were targeted by Congress in the pending TEFRA legislation. Previously, on January 31, 1983, another *Washington Post* article entitled, “Rent-a-Navy,” concluded that the TAKX Program should be terminated because the bulk of its cost was hidden forever from public scrutiny in lost tax revenue to the Treasury.⁷ The leases, it argued, should be prohibited as a blatant “evasion of budgetary limits.”

It is not clear how *The Washington Post* came to see the TAKX leases as such bad public policy. But TAKX’s opponents in Congress clearly were more successful in influencing the public media than they were in influencing the House and Senate leadership. The Congressional political game continued.

On February 28, 1983, Chairman Charles Rangel of the Subcommittee on Oversight of the House Ways and Means Committee held hearings which continued to question the Navy’s judgment to lease the TAKX ships and, thereby, circumvent Congressional review and oversight of the Deal. Rangel’s Committee was not particularly impressed by the assertion by the Principal Deputy Assistant Secretary of the Navy (Shipbuilding and Logistics) that the use of “commercial standards” versus “military standards” saved the Navy \$35 million per ship. Normal “military standards” were not necessary for a cargo ship, she argued; but, normal appropriations law would have required their use anyway. Chairman Rangel followed up the hearings with more questions for the Secretary of the Navy in a public letter dated March 18, 1983. Secretary Lehman responded to Congressman Rangel’s concerns by reiterating the terms of the leases. The Oversight Subcommittee subsequently acknowledged they had no continuing objections to the TAKX Program.

On March 25, 1983, AGL issued a comprehensive rebuttal to the JCT report in which they systematically challenged each of the bases for the JCT opinion that leasing was not cost effective. The original AGL report, the JCT rebuttal, and the AGL response are all very lengthy, complex, and technical documents which require very careful study and very deep awareness of difficult business concepts to understand completely. In the authors’ opinion, no more than a

⁶ Navy promises suppliers tax breaks. (1983, February 25). *The Washington Post*.

⁷ Rent-a-Navy. (1983, January 31). *Washington Post*.



few people outside of AGL or the JCT staff probably fully understood the complex arguments being made or rebutted. However, the political significance of the three documents does not really hinge on a widespread understanding of any of the technical arguments being made.

The August 1982 AGL report served its purpose as a careful report from a credible professional source that reaffirmed the superiority of leasing over buying. One did not have to be able to digest the report fully in order to accept its significance. The JCT rebuttal of February 1983 served its political purpose in challenging the superiority of leasing, from a credible, professional source, whether or not one could fully comprehend its technical arguments. The AGL response in March 1983 served its purpose of reasserting the superiority of leasing by carefully rebutting all of the challenges raised by the JCT.

Whether or not one understood or agreed with the complex present-value arithmetic arguments, the point stood that the Navy was still convinced that leasing was cost effective, in spite of arcane intellectual attacks by opponents of the program. As far as the authors can tell, there was no public criticism of the AGL rejoinder by the JCT or by anyone in Congress.

In the authors' view, these dueling analyses are representative of the role that complex intellectual analysis often plays in policy debates. It is important to present an analytic base for one's policy positions, just as it is important to present an analytic base when challenging a policy. But the success of the policy initiative is much more dependent on the political acumen and political skill of the proponents and opponents than it is on the "intellectual truth content" of the analytical position papers. "Truth" is always ephemeral, and intellectual analysis is often subject to the political interests of the analyst. Credibility is always as much dependent on the "plausibility of denial of subjective bias" as it is on the "truth content" of complex logical arguments.

We consider this resort to complex intellectual arguments and counterarguments regarding the cost-effectiveness of the TAKX leases as a "polemic" (an argument designed more to influence policy than to advance understanding). The arguments play a role in understanding the political success of the program. They also play a role in understanding the success of the program's opponents in stopping any repetition. But the role they play is largely unrelated to the supporting analysis. We try to unravel the competing claims and counterclaims later in the paper, so that we can defuse the cost-effectiveness "polemic" in considering future policy directions. Regardless of the specific arguments, the analytic dimension of the TAKX debate in 1982-1983 was effectively neutralized by the AGL rejoinder report.

Although the Congressional and public media challenges to the TAKX Program were largely finished by June 1983, a new round of congressional actions began. If the TAKX opponents could not derail that program, they seemed willing to do everything they could to see that similar deals would never be repeated.

The Political Response to the Approval of the TAKX Program

Cementing the legality of the TAKX Program was a specific provision of the Appropriations Act of 1985 (P.L. 98-473), which required the Navy each year to encumber the NIF for only that year's lease payments and 10 percent of the possible termination fees. Without this special legislation, the TAKX leases would have over-encumbered the NIF.

The MPS were not even out of their shipyards before three legislative actions were enacted which were clearly intended to ensure that the TAKX Program would never be repeated. In June 1983, the GAO issued an analytic report on the use of leasing by the DoD in which it recommended legislation that would prevent any future long-term leases without Congressional analysis and authorization. It was not clear what such Congressional oversight



might entail until the Defense Authorization Act of 1984 (P.L. 98-94) spelled out these conditions:

- All DoD long-term leases must be specially authorized by law.
- A notice of intent to solicit such leases must be given to the appropriate committees in both houses of Congress.
- A detailed justification for lease versus purchase must be submitted to Congress and that justification must be approved by the OMB and Treasury.
- The OMB and Treasury must jointly issue guidelines as to when leasing may be appropriate.

Clarification of just how restrictive these conditions would be was quick to follow. The required joint OMB/Treasury guidelines were published in 1984 and dictated that any special tax incentives for ship owners (such as accelerated depreciation) be disregarded in any lease versus purchase analysis for DoD leases. The Deficit Reduction Act of 1984 (P.L. 98-369) disallowed accelerated depreciation to the owners of all assets leased to Government entities. The Balanced Budget and Emergency Deficit Control Act of 1985 (P.L. 99-177) further restricted leasing by requiring full, up-front budgetary authority for the estimated present value of all anticipated obligations over the life of any lease.

Finally, OMB Circular A-94, dated October 29, 1992, requires that any “lease versus purchase” analysis must exclude consideration of any tax revenues to the Treasury from lease payments received by the lessor; further, the analysis, must use the Treasury’s borrowing cost as the discount rate.

Congress, GAO, OMB, and the Treasury Department have spoken—no more long-term leases.

Unraveling the Present-Value Polemic

As noted earlier, AGL originally concluded that leasing was \$43.4 million cheaper per ship, while the JCT concluded that leasing was \$9.7 million more expensive. AGL’s rebuttal to the JCT showed leasing as still \$34.2 million cheaper than purchase. The differences lie primarily in the impact of the tax aspects of the deal on Treasury revenues. The leasing advantage depends on the tax benefits to investors from the depreciation deductions. Without the depreciation deductions, the lease payments would have to be \$72.4 million higher in present-value terms to give the same return to investors. This would negate the leasing advantage.

In Figure 3, the authors summarize the key differences between the AGL and JCT positions in one page. We also include our own conclusions about the key differences. In our view, one page and four footnotes is all that is required to isolate the key issues. Whether or not leasing is cheaper than purchasing hinges on three subjective judgments about the impact of the Deal on Treasury revenues. In other words, the “polemic value” of long and complex reports largely disappears.

We believe our interpretation of these three judgments is sound when one is not trying to choose answers that support political conclusions. We conclude that leasing was substantially more cost-effective than purchase—\$64.4 million per ship. By our calculations, leasing would even be cost-effective at the prevailing rate in 2005—5%. We leave the readers to judge whether the “polemic” can be thus unraveled or not.



Figure 3. Comparing Purchase to Three Different Viewpoints on the Net Total Cost to the Government from Leasing (5% semiannual discounting=10.25% per year) (in millions)

	<u>AGL</u>	<u>JCT</u>	<u>SSS</u>
<u>Ship Cost if Purchased</u>	(182.4)	(178.2) ⁸	(182.4)
Tax revenue from interest on Treasury Bonds Issued to finance the purchase			2.5 ⁹
<u>Leasing</u>	<u>(182.4)</u>	<u>(178.2)</u>	<u>(179.9)</u>
Present value of 25 years of capital hire payments by the Navy	(135.1)	(135.1)	(135.1)
Residual value payments by the Navy at termination, net of tax	(1.7)	(1.7)	(1.7)
Lost tax revenue from the amortization deduction	(.7)	(.7)	(.7)
Tax payments by the lessor on capital hire payments received (46% tax rate)			
Return of capital component	22.0	22.0	22.0
Interest component ¹⁰	39.7	-	-
Lost tax revenue from depreciation deductions ¹¹	(72.4)	(72.4)	-
Total PV with Leasing	<u>(148.2)</u>	<u>(187.9)</u>	<u>(115.5)</u>
Leasing benefit versus purchase	34.2	(9.7)	64.4

⁸ The JCT report excludes from the purchase cost \$4.2 million in base-year legal costs paid to arrange the purchase contracts. AGL and the authors treat the \$182.4 purchase price as given.

⁹ The authors do not believe it is appropriate to assume that the purchase would be fully funded out of tax revenues (as AGL originally did) or fully funded by Treasury borrowing (as JCT did). We assume the purchase is financed by a mix of tax revenues and government borrowing that reflects the overall percentage of deficit financing in the federal budget that year (21% deficit financing via Treasury borrowing). We also assume the purchasers' of Treasury Bonds were, on average, in a 13.5% tax bracket because many investors pay no US tax at all (foreign investor and tax exempt organizations). Thus, the government will receive only 6.2% as much tax revenue as if the purchase price were all borrowed from investors who were in the normal 46% tax bracket [$.21 \times .135 / .46 = .062$]. The \$2.5 million offset to the purchase price is 6.2% of the multiyear present value of the full tax revenue from interest under the lease option (\$39.7 million).

¹⁰ AGL counts the present value of the tax payments by the lessor on the interest component of the capital hire payments as revenue to the government and, thus, as an offset to the Navy cost. The JCT report argued that the investors would receive taxable interest income and pay tax on it regardless of whether they invest in the TAKX leases or not. The item is, therefore, not incremental to the TAKX deal and should not be offset against the lease cost. AGL argued that investors would put their money in tax exempt investments if the TAKX leases were not available. Thus, the tax revenue is incremental to the TAKX deal. The authors believe the JCT is correct—investors would earn taxable interest, whether or not they invested in the TAKX leases. We thus do not count this offset as incremental to the TAKX leases.

¹¹ This item is the present value of the depreciation deductions available to the shipowners. AGL and the JCT argue that this item represents lost tax revenue to the government and, thus, is considered an additional cost of the TAKX leases. The authors believe, as AGL argued elsewhere in their report, that there is a finite pool of leveraged lease investments, based on the pool of investors sophisticated enough to understand such deals and act on them. The TAKX deal does not change the total pool; it only allocates a portion of it to the government because of the favorable risk/return profile (an 11.745% after-tax return on a "hell or high water" basis with the federal government). The leveraged-lease investors will gain these tax deductions, whether or not the TAKX leases exist. Thus, the lost tax revenue is not incremental to the TAKX Program and should not be considered an additional cost of the deal.



The Desirability of Leasing: A 2005 Perspective

Lost in the political backlash against the TAKX leases was the significance of the fact that leasing can reduce the acquisition process from 5 to 7 years to about 2 years, and that use of commercial shipbuilding standards reduced the cost of each TAKX ship by \$35 million (\$182 million versus \$217 million). Actually, the thirteen MPS were built for an average cost of \$177.9 million. The prevailing wisdom in Washington was that conventional appropriations review is worth the cost and should not be circumvented by leases financed through operations and maintenance budgets. The authors believe there are conditions under which leasing should not be viewed so unfavorably.

When Support Equipment is Mission Critical and Funding Is Not Available:

Since the end of the cold war, the military has consistently experienced tight budget constraints. During any budget year, there are always programs that go unfunded. The question that should be asked is, "How critical is the requirement for national security?" If there is a requirement that is mission-critical, then perhaps capital leasing is a viable option. Capital leasing allows the Government to receive and use assets immediately and spread the cash outlays over the lease period rather than front-loading 100 percent of the cost. Thus, leasing can provide the Government with an extremely powerful tool to provide financing alternatives that normally would not be available.

When Leasing Provides Advantages over Procurement:

In the normal military procurement process, the requirements document spells out in great detail the operating characteristics and military specifications for any piece of military equipment. This step normally happens even before Congress approves or appropriates procurement funds. The military specifications found in the requirements document generally require higher standards than commercially built items, and almost always cost more due to their unique features and requirements. In the case of military assets which normally operate in harm's way, building to military specifications ensures survivability.

The mission objective for MPS vessels was to operate in a peaceful environment with only a remote possibility of going in harm's way. Thus, it was not deemed necessary to build the ships to military specifications. But, whether needed or not, appropriations policy would dictate military specifications as the standard. By building the ships to ABS, or commercial, standards, cost savings of \$35 million per ship were passed to the Government.

Leasing can also provide another advantage besides reduced cost. Since commercial shipyards built the ships, the Navy was not allowed to intervene in the construction process. Each shipyard was under a tight contract where delays and design changes were not allowed. In fact, severe penalties were imposed for late delivery of any ship. These factors motivated the shipbuilder to stay on schedule and ensured on-time delivery. The ships were in use within about 24 months.

In situations where commercial design can be adequate, construction under private ownership can avoid the delays and changes common in military-initiated construction. Such changes often place the project over-budget, which increases Congressional oversight. The ability to avoid all these problems through leasing (when the assets do not require special design to military specifications) may be extremely beneficial in terms of delivery and mission.



Leasing should be considered a viable option when the requirement can be filled with a “commercial off-the-shelf” (COTS) application such as computers, medical equipment, standard industrial components, or general-purpose supply equipment. Since the COTS application has already been designed and built, the lengthy procurement process does not add value.

When Timing is Critical:

It might also be advantageous to lease when a requirement is mission-essential and there is not sufficient time for the full procurement process. Shortly after 9-11, for example, there were a multitude of immediate security requirements. One viable option for fulfilling some of these requirements could have been capital leases. Arguably, this context would have applied to the refueling tankers which the Air Force wanted to lease from Boeing in 2002. By leasing, the Government could have fulfilled its requirements in a much shorter time and at greatly reduced up-front outlays.

The Cost Advantage:

If one accepts the authors’ conclusion that leasing can also be more cost effective than purchase, the reduced present value of outflows can also be an additional inducement for leasing when the conditions cited here do prevail.

The Current Legislative Context

In 2005, leasing as a part of acquisition strategy is effectively prohibited by the three pieces of legislation passed in 1983, 1984 and 1985, which were discussed earlier. Re-opening the leasing option would require re-evaluating all three of these consciously constructed impediments.

Tax Deductibility of Depreciation Expense:

The Economic Recovery Act of 1981 allowed companies to realize accelerated depreciation tax benefits over a very short time period. Under this Act, the ACRS allowed the owners of the MPS vessels to depreciate their ships using accelerated rates over a five-year period, even though the lease terms were 25 years. The present value of this depreciation tax shelter to the owners was over \$72 million per ship, a major component of the economic return.

In 1984, the Deficit Reduction Act (P.L. 98-369) modified tax laws to disallow owners the use of ACRS for assets leased to tax-exempt entities, including the Government. The Legislation also reduced the impact of the tax benefits by lengthening the tax life for depreciation to a period equal to 125 percent of the lease term. While this Legislation was not retroactive, if the MPS vessels had been built after 1984, depreciation lives would have been 31.25 years.

This 1984 Act discouraged leasing by reducing the tax benefits. But, the bigger blow was disallowing all depreciation deductions for leases to the Government. If the military hopes to foster an environment where owners desire to lease to the military, Congress needs to re-institute the ability of lessors to take depreciation deductions—at least on a straight-line basis over the ACRS life of the assets.



NIF Encumbrance:

The Balanced Budget and Emergency Deficit Control Act of 1985 (P.L. 99-177) required all DoD agencies to request up-front budget authority for the estimated full present value of all capital lease payments and termination provisions. One of the benefits of leasing in the commercial world is the ability to spread payments over the useful life. If a private-sector user of equipment were required to pay 100 percent of the lease before the equipment is used, there would be no reason to lease. The same concept applies to the Government.

If the Government requires its agencies to obligate the sum of total payments for the first option period plus the termination value (which virtually equals the cost of the total lease) then it will never make financial sense to lease. In order to make leasing a viable option for the Government, special legislation needs to be passed that frames leasing as an annual obligation, which does not encumber the NIF beyond one year.

Prior Approval:

The *1984 Department of Defense Authorization Act* (P.L. 98-94) further restricted Government leasing by requiring all long-term leases with substantial termination values to be specifically authorized by law. It further required Congressional notification prior to issuing a solicitation for leasing. Finally, the Act required a present-value cost comparison be submitted to Congress after OMB and Treasury Department review and evaluation. Given the known aversion to leasing in OMB and Treasury, this law effectively eliminates serious consideration of leasing.

In essence, these three laws make it nearly impossible for leasing to be an effective alternative to purchasing. This forces DoD agencies to use the full procurement process for all asset acquisition.

Conclusion

With a different legislative context and regulatory climate, leasing could be made potentially viable again. Whether such action is desirable depends on one's view of the current environment that effectively precludes leasing. This paper was intended to review the Navy's experience with the TAKX Program to frame a discussion of the prospective efficacy of such programs in 2005.

References



- Bailey, J. & Escoe, M. (2004, December). Innovations in funding the maritime repositioning ships program—A case analysis of the how and why the lease option was successful. [MBA Professional Report]. Monterey, CA: Naval Postgraduate School.
- Engelhardt, B., RADM USN. (2005, February 23). *Department of the Navy FY2006/FY2007 President's Budget*. Washington DC: Office of Budget, Office of the Assistant Secretary of the Navy (Financial Management and Comptroller).
- Furber, D. & Jaeger, H. (2004, June). An examination of the United States Air Force proposed lease of refueling tankers. [MBA Professional Report]. Monterey, CA: Naval Postgraduate School.
- Haslam, P., Koenig, R. & Mitchell, S. (2004, December). An examination of the United States Navy leasing: lessons from the MPS/T-5 experience. [MBA Professional Report]. Monterey, CA: Naval Postgraduate School.
- Jaffe, G. & Karp, J. (2005, January 25). Military faces even deeper cuts. *Wall Street Journal*.
- Navy promises suppliers tax breaks. (1983, February 25). *Washington Post*.
- Pasztor, A. (2005, February 7). Army program could boost defense spending. *Wall Street Journal*.
- Peters, M. A. (1979). Is leasing by the Federal Government a good thing for the American taxpayer? The GAO tanker report—A case study. [PhD Dissertation]. San Francisco: Golden Gate University.
- Rent-a-Navy. (1983, January 31). *Washington Post*.
- Economic Recovery Act of 1981*
- Deficit Reduction Act (P.L. 98-369)*
- Balanced Budget and Emergency Deficit Control Act of 1985 (P.L. 99-177)*
- 1984 Department of Defense Authorization Act (P.L. 98-94)*



THIS PAGE INTENTIONALLY LEFT BLANK



2003 - 2006 Sponsored Acquisition Research Topics

Acquisition Management

- Software Requirements for OA
- Managing Services Supply Chain
- Acquiring Combat Capability via Public-Private Partnerships (PPPs)
- Knowledge Value Added (KVA) + Real Options (RO) Applied to Shipyard Planning Processes
- Portfolio Optimization via KVA + RO
- MOSA Contracting Implications
- Strategy for Defense Acquisition Research
- Spiral Development
- BCA: Contractor vs. Organic Growth

Contract Management

- USAF IT Commodity Council
- Contractors in 21st Century Combat Zone
- Joint Contingency Contracting
- Navy Contract Writing Guide
- Commodity Sourcing Strategies
- Past Performance in Source Selection
- USMC Contingency Contracting
- Transforming DoD Contract Closeout
- Model for Optimizing Contingency Contracting Planning and Execution

Financial Management

- PPPs and Government Financing
- Energy Saving Contracts/DoD Mobile Assets
- Capital Budgeting for DoD
- Financing DoD Budget via PPPs
- ROI of Information Warfare Systems
- Acquisitions via leasing: MPS case
- Special Termination Liability in MDAPs

Logistics Management

- R-TOC Aegis Microwave Power Tubes



- Privatization-NOSL/NAWCI
- Army LOG MOD
- PBL (4)
- Contractors Supporting Military Operations
- RFID (4)
- Strategic Sourcing
- ASDS Product Support Analysis
- Analysis of LAV Depot Maintenance
- Diffusion/Variability on Vendor Performance Evaluation
- Optimizing CIWS Life Cycle Support (LCS)

Program Management

- Building Collaborative Capacity
- Knowledge, Responsibilities and Decision Rights in MDAPs
- KVA Applied to Aegis and SSDS
- Business Process Reengineering (BPR) for LCS Mission Module Acquisition
- Terminating Your Own Program
- Collaborative IT Tools Leveraging Competence

A complete listing and electronic copies of published research within the Acquisition Research Program are available on our website: www.acquisitionresearch.org





ACQUISITION RESEARCH PROGRAM
GRADUATE SCHOOL OF BUSINESS & PUBLIC POLICY
NAVAL POSTGRADUATE SCHOOL
555 DYER ROAD, INGERSOLL HALL
MONTEREY, CALIFORNIA 93943

www.acquisitionresearch.org