



The Objective

- Describe and configure a PLM prototype for United States Air Force (USAF) early acquisition program activities from DoD 5000.2 pre-Milestone A up to Milestone B process.
- Take a design from one program and, with the oversight of the Subject matter Experts within the Air Force, proving out a template that will work for all other programs.
- This includes forms of acquisition where down-select has not been performed, or where more than two vendors may be included within Technical Maturity Readiness Review (TMRR).



- ID Key R&M Cost Drivers
- Failure Definition/Scoring Criteria
- Reliability Allocations
- Feasibility Analysis

To here.

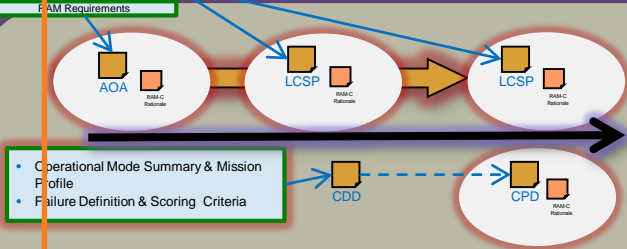

- Operational Mode Summary & Mission Profile
- Failure Definition & Scoring Criteria

- Requirements
- Logical Models
 - Analytics
 - Reporting
- Documents
 - CDRLs
- Parts/systems
- Supporting Technical Data

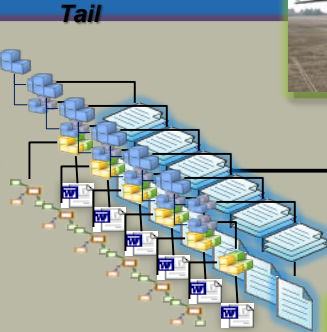

Move the focus from here...

Teamcenter



Requirements Management Process

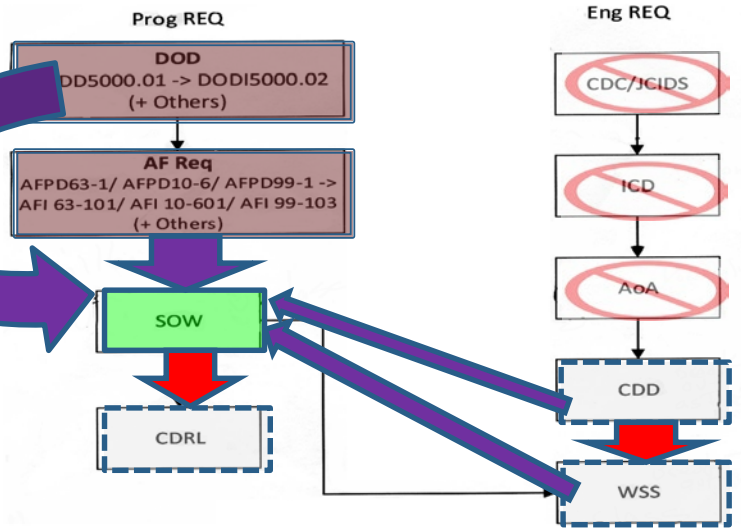

CDC = Capability Development Council
 JCIDS = Joint Capabilities Integration & Development System
 ICD = Initial Capability Document
 AoA = Analysis of Alternatives
 CDD = Capability Development Document
 WSS = Weapon System Spec

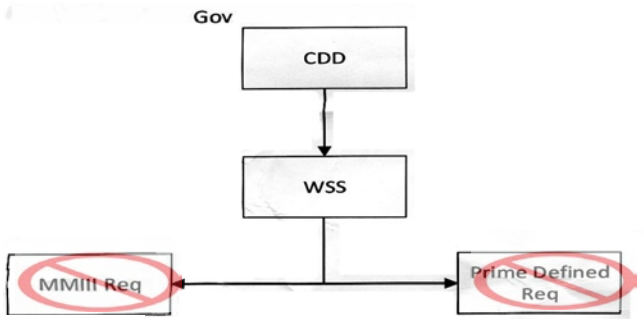
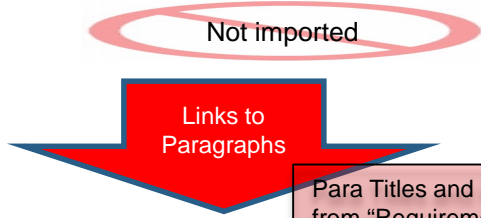

Requirements Cameo Doors TC Req

Architecture
 - Enduring Arch
 - Analytical Arch
 - Gov Arch





Workflows

BP – Submittal Approval

