

NPS-LM-06-048



## ACQUISITION RESEARCH SPONSORED REPORT

---

**Process Improvement at the Aircraft Intermediate  
Maintenance Detachment (AIMD) at Naval Air Station  
Whidbey Island**

**15 December 2006**

**by**

**LCDR Eric Jafar, USN**

**LCDR(sel) Terence Noel C. Mejos, USN, and**

**LT Chieh Yang, USN**

**Advisors: Dr. Keebom Kang, Associate Professor, and  
Dr. Uday Apte, Professor**

Approved for public release, distribution unlimited.

Prepared for: Naval Postgraduate School, Monterey, California 93943



ACQUISITION RESEARCH PROGRAM  
GRADUATE SCHOOL OF BUSINESS & PUBLIC POLICY  
NAVAL POSTGRADUATE SCHOOL

The research presented in this report was supported by the Acquisition Chair of the Graduate School of Business & Public Policy at the Naval Postgraduate School.

**To request Defense Acquisition Research or to become a research sponsor, please contact:**

NPS Acquisition Research Program  
Attn: James B. Greene, RADM, USN, (Ret)  
Acquisition Chair  
Graduate School of Business and Public Policy  
Naval Postgraduate School  
555 Dyer Road, Room 332  
Monterey, CA 93943-5103  
Tel: (831) 656-2092  
Fax: (831) 656-2253  
e-mail: [jbgreene@nps.edu](mailto:jbgreene@nps.edu)

Copies of the Acquisition Sponsored Research Reports may be printed from our website [www.acquisitionresearch.org](http://www.acquisitionresearch.org)



ACQUISITION RESEARCH PROGRAM  
GRADUATE SCHOOL OF BUSINESS & PUBLIC POLICY  
NAVAL POSTGRADUATE SCHOOL

# Abstract

This project focuses on the J52-P408 engine repair process and the implementation of the “AIRSpeed” program at the Aircraft Intermediate Maintenance Department (AIMD) at Naval Air Station Whidbey Island (NASWI), WA. The project was conducted with the sponsorship and assistance of Program Executive Office Ships (PEO SHIPS) and Program Executive Office Integrated Warfare Systems (PEO IWS). The goal of this project is to analyze how the leadership of AIMD incorporated Theory of Constraints (TOC), Just in Time (JIT), Lean, Six-Sigma, and Lean Six-Sigma methodologies in the engine repair process, and examine the effects of its application in relation to repair cycle time and overall readiness level. This report will describe and compare the earlier and the current AIRSpeed engine removal and repair processes, starting from the flight line to the ready for issue (RFI) pool at AIMD. Using simulation modeling tools and private industry production and inventory management philosophies, we will make recommendations for further improvement in the repair process. We will examine how the application of AIRSpeed processes contributes to the mission readiness of the United States Navy and Marine Corps’ fleet of EA-6B Prowler aircraft, while reducing operation and maintenance cost.

**Keywords:** AIRSpeed, Lean, Six-Sigma, Engine Repair Process, Repair Cycle Time, Value Stream Mapping, Process Improvement and Arena Simulation.



THIS PAGE INTENTIONALLY LEFT BLANK



ACQUISITION RESEARCH PROGRAM  
GRADUATE SCHOOL OF BUSINESS & PUBLIC POLICY  
NAVAL POSTGRADUATE SCHOOL

# Acknowledgements

We would like to thank Professors Keebom Kang and Uday Apte for their guidance and support during this project. Also, we are grateful for the support of AIMD at Naval Air Station, Whidbey Island, Washington in providing background information on the AIRSpeed process at the Power Plants Division, as well as the assistance of CDR Katherine D. Erb, LCDR James R. Galyean, LT John S. Stevens, ADCS (AW/SW) Romulus J. Devilla, ATCS (AW/SW) Bryan C. Barton, AT1 (AW) Joshua N. Cook, AD1 (AW) Juan M. Ocanas, and AD1 (AW) Cody A. Shouse.

Om Gum Ganapatayei Namaha (salutations to the remover of obstacles). To my loving wife Indira and awesome son Kevin, thank you for your patience and understanding during my tour at the Naval Postgraduate School in Monterey, California. I know you both have given up a lot for me to earn my Master's degree. I could not have done it without all of your love and support. Also, I would like to thank my mother-in-law Amis for taking care of Kevin and for all of the hot meals while I was going to school, and for your kind support. May God Bless you! To my teammates Terry Mejos and Chieh Yang, I could not have asked for a better couple of guys to work with on this project. Many thanks for all of your hard work, the good times, the wonderful memories, and most importantly, your friendship.

– *Lieutenant Commander Eric Jafar*

To my parents, Gregory and Pitzu Krueger, who are my best friends and confidants, thank you for your unwavering support. These academic triumphs pale in comparison to what you two have taught me about life. Thank you.

To my children, Jay, Christopher, and Amanna, for being my greatest treasures—you could never be replaced. You are my most remarkable accomplishment. I am grateful to you for supportively enduring many long days and late nights of study—I love you. The quest for knowledge is a lifelong endeavor, and



I hope I can be an example to all three of you and be there to support you when you decide to pursue the journey.

To my advisors, Professors Keebom Kang and Uday Apte, for your continued inspiration, tutelage, and mentorship that I know I can always draw from. I look forward to researching broad-ranging topics for you in the future.

To my project team members, LCDR Eric Jafar and LT Terry Mejos, thank you for the constant support and for providing a clear direction. I will always be grateful for your contributions and guidance. I look forward to returning to the Fleet and with good fortune I will be able to serve with you in future commands.

*– Lieutenant Chieh Yang*

“Mabuhay at maraming salamat po sa inyo.” is a humble, jovial, and most respectful way of saying thanks in my native language in the Philippines. My contributions to this project were made possible by the inspiration bestowed by the people around me. To our Divine Creator, who I continually turn to for strength, wisdom, hope, and guidance, I am most gracious. To Cheryl, who always inspires and supports me, and unfailingly endures the sacrifices of a military spouse, I am most fortunate. To Terence, Camille, and Cailene, who patiently await my arrival and refresh my tired flesh after a long day of work, I am most proud. To my parents, who serve as my foundation for every endeavor, I am most honored. To Ate Nerissa, who always reminds me of youth and grace, I am most blessed.

Furthermore, this project could not have been effectively crafted without the cohesiveness of this team. To Eric Jafar and Chieh Yang, thank you for the entertainment, refreshments, and most of all, friendship. To Rich Mastowski, thank you for interlacing our ideas together and turning our works into one useful product.

*– Terence Noel Corpus Mejos, LT, USN*



## About the Authors

**Lieutenant Commander Eric Jafar**, Supply Corps, United States Navy, is currently assigned to the Navy Expeditionary Combat Command (NECC) Staff at the Naval Amphibious Base, Little Creek, Virginia.

Lieutenant Commander Jafar came to the Navy Expeditionary Combat Command (NECC) Staff from an assignment as a student in the Graduate School of Business and Public Policy at the Naval Postgraduate School, Monterey, California. Prior to that assignment he served as the Principal Assistant for Logistics and Principal Assistant for Services aboard *USS Theodore Roosevelt* (CVN 71), Norfolk, Virginia.

Lieutenant Commander Jafar has earned qualifications as a Surface Warfare Supply Officer, and Aviation Supply Officer. His tours afloat as an officer began with a tour as First Lieutenant, *USS Vincennes* (CG 49), Supply Officer in *USS George Philip* (FFG-12), and Principal Assistant for Logistics and Principal Assistant for Services, *USS Theodore Roosevelt* (CVN-71).

Lieutenant Commander Jafar's assignments ashore include Department of Defense Navy Acquisition Contracting Officer Intern at the Defense Supply Center, Richmond, Virginia, and Logistics Management Student at the Naval Postgraduate School, Monterey, California.

Lieutenant Commander Jafar grew up in New York and earned his bachelor's degree at San Diego State University, San Diego, California, and was commissioned in January 1996 through the Enlisted Commissioning Program as an Ensign. He received a master's degree in Business Administration with a subspecialty in Supply Chain Management from the Naval Postgraduate School, Monterey, California.

His personal awards include the Joint Commendation Medal, the Navy and Marine Corps Commendation Medal (third award), and the Navy and Marine Corps Achievement Medal (third award).

**LCDR(sel) Terence Noel C. Mejos**, Aerospace Maintenance Duty Officer, United States Navy, was born on October 30, 1970 in Olongapo City, Philippines. He graduated from the Philippine Air Transport and Training School of Aeronautics with a Bachelor of Science degree in Aeronautical Engineering in 1990. He also graduated from Southern Illinois University at Carbondale with a Bachelor of Science degree in Aviation Management in 1994. He is a licensed Aeronautical Engineer in the Philippines.

He enlisted in the Navy in 1991 as an Aircraft Structural Mechanic. He completed the military indoctrination course at the Naval Recruit Training Center in San Diego, CA, and received the Most Outstanding Recruit Award. He attended the



Aircraft Structural Mechanic “A” School at the NATTC Millington, TN, and finished top of his class. His tours of duty and accomplishments as an enlisted include:

- VF-124/101 NAS Miramar, San Diego, CA (1992-95). Collateral Duty Inspector and Low Power Turn Qualified for F-14A/D “Tomcat” model aircraft.
- VP-1 NAS Whidbey Island, Oak Harbor, WA (1995-98). Quality Assurance Representative and Aviation Gas-Free Engineer/Qualifier for P-3 “Orion” model aircraft.

He completed the Officer Candidate School in Pensacola, FL in June, 1998. His first AMDO assignment was in HSL-41 at NAS North Island, San Diego, CA. He served there as Aircraft Assistant Division Officer, Material Control Officer and Material/Maintenance Control Officer. In 2002, he reported aboard the USS Carl Vinson in Aircraft Intermediate Maintenance Department, and served there as Quality Assurance Officer, IM-2 (General Aircraft Maintenance), and IM-3 (Aircraft Avionics and Armament) Division Officer. He also performed collateral duties, such as, Departmental 3M Officer and Damage Control Repair Locker Officer. While on Vinson, he completed the 2003 Western Pacific deployment in support of Operation Southern Watch, and majority of the 2005 “global” deployment in support of the Global War on Terrorism. In 2005, he reported aboard the Naval Postgraduate School as a Defense-Focused Master of Business Administration Program student, specializing in Material Logistics Support.

His personal awards include the Navy and Marine Corps Commendation Medal (one award), and the Navy and Marine Corps Achievement Medal (three awards).

LCDR(sel) Terry Mejos is married to Cheryl Avenido of Cagayan de Oro, Philippines. They have three children: Terence (10), Camille (3) and Cailene (6 months).

**Lieutenant Chieh Yang**, Aviation Limited Duty Officer, United States Navy, is an immigrant from Taiwan. He enlisted in the Navy in 1986 as Aviation Structural Mechanic (Structural). In December 1996 He graduated from the University of Illinois at Carbondale with a Bachelor of Science in Aviation Management. He was commissioned on October 1, 2002 as an Ensign via the Navy’s Limited Duty Officer Program.

On December 13, 1986, LT Yang reported for duty to Fleet Logistics Support Squadron 30 (VRC-30) in San Diego, California. He deployed on all west coast based aircraft carriers in support of squadron carrier qualification. In May 1990 he deployed onboard USS Constellation in support of Rim of the Pacific Exercise (RIMPAC). In September 1990 he checked onboard Helicopter Combat Support Squadron 11 (HC-11) for duty. In December 1990, he made his first 6 month





deployment aboard USS Kansas City (AOR-3) in support of Operation Desert Shield/Storm. In September 1993, he was deployed aboard USS New Orleans (LPH-11) in support of Exercise Valiant Usher and Operation Restore Hope at Mogadishu, Somalia. In July 2001 he checked onboard Service School Command at Naval Training Center, Point Loma, California. After completing his Bachelor degree he received orders to Early Airborne Warning Squadron 115 (VAW-115) in Naval Air Facility Atsugi, Japan. Upon checking into VAW-115 in January 1997, within a week he was deployed onboard USS Independence in support of Exercise Southern Swing and in February 1998 made another deployment in support of Operation Southern Watch (OSW) in the Persian Gulf. After the deployment he was selected for Officer Candidate School in Pensacola, Florida. Due to personal reasons, he declined the opportunity and was sent back to HC-11. In November 1998 he returned to serve a second tour at HC-11. In February 1999 he was deployed onboard USS Sacramento in Support of OSW and Maritime Interception Operation (MIO). After the deployment he was hand-selected to be the Day shift Maintenance Control Leading Petty Officer for one year. After Maintenance Control, he was selected to serve as Detachment TWO's chief and flight deck coordinator aboard the USS Nimitz in support of her voyage around the Cape of Good Hope to her new Homeport in Naval Operating Base Coronado in San Diego, California. In January 2002 he checked onboard Aircraft Intermediate Maintenance Department at NASNI. In February 2002 he was selected as an Aviation Limited Duty Officer and was commissioned on October 1, 2002. He was assigned to Helicopter Combat Support Squadron 6 (HC-6) as his first commissioned tour. In December 2002 he reported for duty and served as a Detachment Maintenance Officer and deployed onboard the USS BATAAN in support of Operation Iraq Freedom (OIF) and Enduring Freedom (OEF). In June 2005 he reported aboard Naval Postgraduate School serving as a student to obtain the Master of Business Administration Degree that specializes in logistics.

His personal accomplishment includes: Chosen twice as VRC-30's junior sailor the month. He was selected as AOR-3's Junior Sailor of the Month, for March and AOR-3's Junior Sailor of the Cruise (1991). At HC-11 he was meritoriously advanced to Second Class Petty Officer under the Command Advancement Program (CAP). He earned the Enlisted Aviation Warfare Specialist qualification. The selection to EEAP (1994), OCS (1998), LDO program (2002), selected as HC-11 and Helicopter Combat Support Wing Pacific's Sailor of the Year for 2000. He has received one Navy Commendation Medal and five Navy Achievement Medals.

He has three children living in Monterey, California, they are: Jay Michael 17, Christopher Blake 13, and Amanna 5.



THIS PAGE INTENTIONALLY LEFT BLANK



ACQUISITION RESEARCH PROGRAM  
GRADUATE SCHOOL OF BUSINESS & PUBLIC POLICY  
NAVAL POSTGRADUATE SCHOOL

NPS-LM-06-048



## ACQUISITION RESEARCH SPONSORED REPORT

---

**Process Improvement at the Aircraft Intermediate  
Maintenance Detachment (AIMD) at Naval Air Station  
Whidbey Island**

**15 December 2006**

**by**

**LCDR Eric Jafar, USN**

**LCDR(sel) Terence Noel C. Mejos, USN, and**

**LT Chieh Yang, USN**

**Advisors: Dr. Keebom Kang, Associate Professor, and  
Dr. Uday Apte, Professor**

Disclaimer: The views represented in this report are those of the author and do not reflect the official policy position of the Navy, the Department of Defense, or the Federal Government.



ACQUISITION RESEARCH PROGRAM  
GRADUATE SCHOOL OF BUSINESS & PUBLIC POLICY  
NAVAL POSTGRADUATE SCHOOL

THIS PAGE INTENTIONALLY LEFT BLANK



ACQUISITION RESEARCH PROGRAM  
GRADUATE SCHOOL OF BUSINESS & PUBLIC POLICY  
NAVAL POSTGRADUATE SCHOOL

# Table of Contents

<b>List of Symbols, Acronyms, and/or Abbreviations .....</b>	<b>xiii</b>
<b>I. Introduction .....</b>	<b>1</b>
A. Background .....	1
B. Purpose .....	4
C. Research Question.....	5
<b>II. Background .....</b>	<b>7</b>
A. Naval Aviation Maintenance Program .....	7
B. Naval Air Station Whidbey Island .....	11
<b>III. Literature Review .....</b>	<b>15</b>
A. Theory of Constraints (TOC) .....	15
B. Just-in-Time (JIT) System .....	17
C. Lean Production .....	24
D. Total Quality Management (TQM) .....	28
E. Six Sigma .....	29
F. LEAN SIX-SIGMA (LSS) .....	33
<b>IV. Process Description .....</b>	<b>35</b>
A. Overview .....	35
B. SQUADRON ENGINE REMOVAL PROCESS .....	35
C. J52 Shop Pre-Airspeed Engine Repair Process.....	37
D. Pre-Airspeed Repair Process Analysis.....	42
E. Cultural Transformation .....	48
F. Site Visits' Observations.....	52
G. AIRSpeed Engine Repair Process .....	54
<b>V. Simulation Model .....</b>	<b>65</b>
A. Overview .....	65
B. Establishment of Baseline .....	66
C. Simulation Model Assumption .....	73
D. Simulation Model Limitations.....	75
E. Simulation Results and Analysis .....	76



F.	Embellishments and Analysis.....	83
G.	Maximizing Operational Availability .....	91
<b>VI. Conclusions and Recommendations.....</b>		<b>93</b>
A.	Conclusions.....	93
B.	Recommendations.....	94
C.	Criticisms on “Lean”.....	95
D.	Summary .....	97
E.	Future if Naval Aviation Repair Facilities .....	98
<b>List of References.....</b>		<b>101</b>
<b>Initial Distribution List .....</b>		<b>105</b>



## List of Symbols, Acronyms, and/or Abbreviations

AGI	Avraham Y. Goldratt Institute, LLP (consultants)
AIMD	Aircraft Intermediate Maintenance Department
AMSU	Aircraft Maintenance Screening Unit
Ao	Operational Availability
ASD	Aviation Support Division
ATAF	All Tools Accounted For
AWP	Awaiting Parts
BCM	Beyond Capability of Maintenance
CAG	Carrier Air Wing
CCS	Component Control Section
CDI	Collateral Duty Inspector
COMNAVAIRFOR/CNAF	Commander, Naval Air Forces
CNO	Chief of Naval Operations
COMVAQWINGPAC	Commander, Electronic Attack Wing, Pacific
D-level	Depot-level (maintenance)
DMAIC	Define, Measure, Analyze, Improve, Control
DMADV	Define, Measure, Analyze, Design, Verify
DoD	Department of Defense
DoN	Department of the Navy
DBR	Drum-Buffer Rope
DRC	Dynamics Research Corporation (consultants)
FCA	Field Cognizant Activities
FIFO	First-In-First-Out
FOD	Foreign Object Damage (engine damage from foreign materials)
FRC	Fleet Readiness Center
GE	General Electric
I-level	Intermediate-level (maintenance)
IMA	Intermediate Maintenance Activities



IW	In Work
JIT	Just-in-Time
LSS	Lean Six-Sigma
MALS	Marine Aviation Logistics Squadron
MATCON	Material Control
MC	Mission Capable
MDT	Mean Down Time
MDU	Material Delivery Unit
MEI	Major Engine Inspection
MTBF	Mean Time Between Failure
NALCOMIS	Naval Aviation Logistics Command Maintenance Information System
NAMP	Naval Aviation Maintenance Program
NASWI	Naval Air Station Whidbey Island
NATO	North Atlantic Treaty Organization
NAVAIR	Naval Air Systems Command
NAVRIIP	Naval Aviation Readiness Integrated Improvement Programs
NADEP	Naval Aviation Depot
NMC	Non-Mission-Capable
NRFI	Not Ready for Issue
OIC	Officer-in-Charge
O-level	Organizational-level (maintenance)
OMA	Organizational Maintenance Activities
PC	Production Control
PEB	Pre-Expend Bin (Unit)
PMU	Program Management Unit
QAR	Quality Assurance Representative
QECK	Quick Engine Change Kit
RFI	Ready for Issue
RFT	Ready for Test
ROI	Return on Investment





SAR	Search and Rescue
SE	Support Equipment
SPT	Shortest Processing Time
SRS	Supply Response Section
SSU	Supply Support Unit
TAD	Temporary Additional Duty
TD	Technical Directive
T/M/S	Type, Model, Series
TPS	Toyota Production System
TQM	Total Quality Management
TOC	Theory of Constraints
VSM	Value Stream Mapping



THIS PAGE INTENTIONALLY LEFT BLANK



ACQUISITION RESEARCH PROGRAM  
GRADUATE SCHOOL OF BUSINESS & PUBLIC POLICY  
NAVAL POSTGRADUATE SCHOOL

# I. Introduction

## A. Background

For many years, Naval aviation measured command performance and mission success according to operational availability<sup>1</sup> or readiness rate. As guidance, the Chief of Naval Operations (CNO) periodically publishes a set of standards for all Navy units to maintain. Operational commanders aim not only to surpass this standard, but to achieve perfection. Though most commanders are successful in attaining mission-capable (MC) rates above the CNO's set readiness standard, many overlook the actual cost of achieving such rates. With a mindset of reporting the highest operational availability rate, commanders and maintenance managers in the aviation community instinctively compete for replacement parts, personnel, and higher repair capability according to the level of maintenance<sup>2</sup> their units are allowed to accomplish. Based on their combined 56 years of experience in Naval supply and aviation maintenance, the authors opine that redundant or non-value-added procedures and management practices have been culturally ingrained among maintainers and managers in the Naval aviation community, which unnoticeably contribute to fluctuations in the levels of production and readiness. Decades of "in house" competition resulted in an accumulation of excessive spare parts, unnecessary personnel, and redundant repair procedures.

There are two ways of achieving a high level of operational availability. The first is to exceed the required level of spares needed and the other is to improve Mean Time Between Failures (MTBF), decrease Maintenance Down Time (MDT),

---

<sup>1</sup> Operational Availability ( $A_o$ ) is a commonly used readiness measure for weapon systems. This value provides the percentage of weapon systems in MC status; this value also represents the percentage of time that a system is in MC status. Keebom Kang, Logistics Engineering: Lecture Notes, Graduate School of Business and Public Policy, 2006, p. 17. Operational Availability = number of MC systems/total number of systems.

<sup>2</sup> See Chapter II for more information about the different levels of Naval aircraft maintenance.



and reduce total cycle time. The AIRSpeed program was implemented to solve these issues. Therefore, a management norm that requires careful analysis is the practice of stocking excess spare parts in an effort to reduce equipment down time by eliminating lead time for replacement parts and achieving a small percentage increase in readiness. Because of this perceived value created from having available parts on site, hoarding excessive spare parts becomes the alternative solution for readiness rate issues, which results in accountability problems and shortage of spare parts at other maintenance facilities. Facilities experiencing a shortage of parts ends up resorting to cannibalization<sup>3</sup> which poses an adverse impact on equipment repair cycle time (i.e., turnaround time).

In January 2001, the Comptroller General of the United States reported that lack of control and accountability over inventory and equipment are two major management challenges or inefficiencies faced by the Department of Defense (DoD).<sup>4</sup> In fiscal years 2001 and 2002, the Navy reportedly spent over \$8 billion in operations and maintenance appropriations to acquire more spare parts.<sup>5</sup> Consequently, the Navy accumulated over 475,000 cannibalizations between fiscal years 1996 and 2000, which translates into millions of maintenance hours.<sup>6</sup> Additionally, management inefficiencies in its aircraft repair facilities cost the Department of the Navy (DoN) billions of dollars. Meanwhile, the cost of operating and maintaining aircraft continues to increase, while the DoD's budget steadily declines—which affects the future capability of the Navy to buy more ships and

---

<sup>3</sup> Cannibalization is the process of transferring serviceable parts from one weapon system (i.e., aircraft, engine, etc.) for installation on another.

<sup>4</sup> General Accounting Office, "Major Management Challenges and Program Risks: Department of Defense," GAO-01-244, January 2001, p. 32 and 66.

<sup>5</sup> General Accounting Office, "Defense Inventory: Navy Logistics Strategy and Initiatives Need to Address Spare Parts Shortages," Report to the Chairman, Subcommittee on Defense, of the House Committee on Appropriations, GAO-03-708, June 2003, p. 1.

<sup>6</sup> General Accounting Office, "Military Aircraft: Cannibalization Adversely Affects Personnel and Maintenance," Testimony before the Subcommittee on National Security, Veterans Affairs, and International Relations, of the House Committee on Government Reform, GAO-01-693T, May 2001, pp. 1-3.



aircraft. In response to this behavior, the CNO directed the Navy to operate more efficiently,<sup>7</sup> thus, Naval Air Systems Command (NAVAIR) turned toward successful organizations in the private sector in search of production philosophies and techniques that could be applicable to Naval aircraft maintenance facilities, i.e., Naval Aviation Depot (NADEP) and Aircraft Intermediate Maintenance Detachment (AIMD). As a result, NAVAIR mandated the implementation of a cost-wise readiness initiative leveraging the Theory of Constraints (TOC), Just-in-Time (JIT), Lean, Six-Sigma, and Lean Six-Sigma methodologies that sparked a Fleet-wide transformation under the AIRSpeed program.<sup>8</sup> NAVAIR's goal is to reduce production turnaround time by eliminating unnecessary procedures. In July 2003, AIRSpeed concepts were first implemented at NADEP facilities and produced substantial cost savings for the Navy, which realized that these practices could also increase performance and readiness levels. After the initial foundation was established at NADEP facilities, the implementation process commenced at intermediate maintenance activities (IMA).

In early April 2004, AIRSpeed concepts were first introduced at NASWI's J52-P408 Engine Repair Shop under the guidance of consultants Avraham Y. Goldratt Institute, LLP (AGI) and Dynamics Research Corporation (DRC).<sup>9</sup> The Navy contracted with both firms to develop, implement, and sustain AIRSpeed concepts at aircraft repair facilities. AGI is headquartered in New Haven, Connecticut and has over 19 years of experience in TOC development, implementation, and education. DRC is headquartered in Andover, Massachusetts and is experienced in providing workshops for the Lean and Six-Sigma methodologies.

---

<sup>7</sup> Department of the Navy, Office of Information, "CNO Guidance for 2003," retrieved on August 13, 2006, from <http://www.chinfo.navy.mil/navpalib/cno/clark-guidance2003.html>

<sup>8</sup> Mark Nieto, "Enterprise AIRSpeed," *The Navy Supply Corps Newsletter*, Vol. 68, Iss. 5, September/October 2005, p. 10.

<sup>9</sup> PRNewswire, "U.S. Navy Awards a Major Contract to a Connecticut Small Business," January 2006, retrieved on July 19, 2006 from <http://www.prnewswire.com/cgi-bin/stories.pl?ACCT=104&STORY=/www/story01-13-2006/0004248807&EDATE>



Initial assessments by AIMD Whidbey Island AIRSpeed Teams<sup>10</sup> of the production area and repair procedures in the J52 shop revealed several “muda.” Under the Lean concept, muda is the Japanese word for waste or non-value-added.<sup>11</sup> This concept was adopted from the Toyota Production System developed by Taiichi Ohno.<sup>12</sup> By eliminating muda and streamlining the repair process, AIMD projected that the J52 engine repair cycle time would decrease from 468 hours to 233 hours.<sup>13</sup>

## B. Purpose

Currently, AIMD NASWI has implemented these processes and is providing increased engine availability for the EA-6B community. We will analyze how the leadership of AIMD incorporated the TOC, JIT, Lean, Six-Sigma, and Lean Six-Sigma methodologies in the engine repair process, and examine the effects of its application in relation to repair cycle time and overall readiness level. We will describe and compare the pre and present AIRSpeed engine removal and repair processes, starting from the flight line to the ready for issue (RFI) pool at the AIMD. Using simulation modeling tools and private industry production and inventory management philosophies, we will make recommendations for further repair process improvement. We will examine how the application of AIRSpeed processes contributes to the mission readiness of the United States Navy and Marine Corps’ fleet of EA-6B Prowler aircraft, while reducing operation and maintenance costs.

---

<sup>10</sup> The AIRSpeed Team consists of one officer (O-3), one chief petty officer (E-7), and four senior petty officers (E-5 – E-6).

<sup>11</sup> William M. Feld, *Lean Manufacturing: Tools, Techniques, and How to Use Them*, Boca Raton, FL: St. Lucie Press, 2001, p. 10.

<sup>12</sup> David McBride, “The 7 Manufacturing Wastes,” August 2003, retrieved on July 10, 2006 from <http://www.emsstrategies.com/dm090203article2.html>

<sup>13</sup> Betsy Haley, “EA-6B Thrives with NAVRIIP/Enterprise AIRSpeed,” November 2004, retrieved on May 13, 2006 from <http://www.cnaf.navy.mil/airspeed/main.asp?ItemID=413>



### C. Research Question

Based on the authors' Naval aviation maintenance and supply experiences with regard to implementing changes on a Navy-wide scale, the changes necessary in order to implement AIRSpeed present the greatest challenge and opportunity as far as who and what are affected. AIRSpeed puts sensible ideas into action that decades before seemed infeasible. It aims to close the gap between supply and maintenance departments, synchronize maintenance activities' differing mission objectives, and introduce a new work culture vastly different than what most personnel (maintainers and managers) learned and embraced from their predecessors. The authors are interested in analyzing how AIRSpeed concepts were implemented at military repair facilities, specifically in the J52 shop. What benefits did these improvements provide to the repair cycle time and engine availability for the EA-6B fleet? What other areas in the logistics pipeline should be improved on to further increase engine availability? These are the questions we address in this research.



THIS PAGE INTENTIONALLY LEFT BLANK





## II. Background

### A. Naval Aviation Maintenance Program

The Commander of Naval Air Forces (CNAF) established the Naval Aviation Maintenance Program (NAMP). The NAMP outlines the mission of the three levels of maintenance: (1) Depot-level (D-level) maintenance; (2) Intermediate-level (I-level) maintenance; and (3) Organizational-level (O-level) maintenance. The following paragraphs are excerpts from the Commander, Naval Air Forces (COMNAVAIRFOR) Instruction 4790.2, Volume I, dated 1 February 2005.

#### 1. Objective

The objective of the NAMP is to achieve and continually improve aviation material readiness and safety standards established by the CNO/COMNAVAIRFOR, with coordination from the Commandant of the Marine Corps, with optimum use of manpower, material, facilities, and funds. COMNAVAIRFOR aviation material readiness standards include:

- Repair of aeronautical equipment and material at that level of maintenance, which ensures optimum economic use of resources.
- Protection of weapon systems from corrosive elements through the prosecution of an active corrosion control program.
- Application of a systematic, planned maintenance program and the collection, analysis, and use of data in order to effectively improve material condition and safety.

#### 2. Levels of Maintenance

The NAMP is founded on the three-level maintenance concept and is the authority governing management of O-level, I-level, and D-level aviation maintenance. It provides the management tools required for efficient and economical use of personnel and material resources in performing maintenance. It also provides the basis for establishing standard organizations, procedures, and responsibilities for



the accomplishment of all maintenance on Naval aircraft, associated material, and equipment.

The division of maintenance into three levels allows management to:

- Classify maintenance functions by levels.
- Assign responsibility for maintenance functions to a specific level.
- Assign maintenance tasks consistent with the complexity, depth, scope, and range of work to be performed.
- Accomplish any particular maintenance task or support service at a level that ensures optimum economic use of resources.
- Collect, analyze, and use data to assist all levels of NAMP management.

**a. Organizational-Level Maintenance**

O-level maintenance is performed by an operating unit on a day-to-day basis in support of its own operations. The O-level maintenance mission is to maintain assigned aircraft and aeronautical equipment in a fully mission capable status, while continually improving the local maintenance process. While O-level maintenance may be done by I-level or D-level activities, it is usually accomplished by maintenance personnel assigned to aircraft reporting custodians. O-level maintenance functions generally can be grouped under the categories of:

- Inspections.
- Servicing.
- Handling.
- On-equipment corrective and preventive maintenance. (This includes on-equipment repair, removal, and replacement of defective components.)
- Incorporation of technical directives (TDs), less support equipment (SE), within prescribed limitations.
- Record keeping and reports preparation.



- Age exploration of aircraft and equipment under reliability centered maintenance.

**b. Intermediate-Level Maintenance**

The I-level maintenance mission is to enhance and sustain the combat readiness and mission capability of supported activities by providing quality and timely material support at the nearest location with the lowest practical resource expenditure.

I-level maintenance consists of on- and off-equipment material support and may be grouped as follows:

- Performance of maintenance on aeronautical components and related SE.
- Field calibration activities, which perform I-level calibration of designated equipment.
- Processing aircraft components from stricken aircraft.
- Providing technical assistance to supported units.
- Incorporation of TDs.
- Manufacture of selected aeronautical components, liquids, and gases.
- Performance of on-aircraft maintenance when required.
- Age exploration of aircraft and equipment under reliability centered maintenance.

**c. Depot-Level Maintenance**

D-level maintenance is performed at or by Naval aviation industrial establishments to ensure the continued flying integrity of airframes and flight systems during subsequent operational service periods. It is also performed on material requiring a major overhaul or rebuilding of parts, assemblies, subassemblies, and end items. It includes manufacturing parts, modifying, testing, inspecting, sampling, and reclamating. D-level maintenance supports O-level and I-level maintenance by providing engineering assistance and performing maintenance beyond their capabilities. D-level maintenance functions may be grouped as follows:



- Aircraft standard D-level maintenance (standard and special rework).
- Rework and repair of engines, components, and SE.
- Calibration by Navy calibration laboratories and Navy primary standard laboratories.
- Incorporation of TDs.
- Modification of aircraft, engines, and SE.
- Manufacture or modification of parts or kits.
- Technical and engineering assistance by field teams.
- Age exploration of aircraft and equipment under reliability centered maintenance.

### 3. AIRSpeed

AIRSpeed is Naval Aviation Readiness Integrated Improvement Program's (NAVRIIP's) architecture for operationalizing cost-wise readiness across the Naval Aviation Enterprise. It is characterized by an integrated culture of self-sustaining, Continuous Process Improvement (CPI) aligned toward delivering mission requirements at reduced resource costs thus enabling world-class logistics excellence for the Naval Aviation Enterprise in support of the T/M/S teams. AIRSpeed provides the planning, training, integration, sustainment, and monitoring of business practices across the Naval Aviation Enterprise. Functions include practical application, progress assessment, communications, innovation, and documentation of barriers and effects-cause-effects (lessons learned).

To revolutionize the way Naval aviation does business, AIRSpeed will focus on the following fundamental principles:

- Properly manage ready-for-tasking aircraft.
- Manage inventory and investments (parts, equipment, and facilities).
- Reduce operating expenses.
- Identify and address interdependencies.



- Identify constraints.
- Manage and reduce variability.
- Create a culture of continuous process improvement.

## B. Naval Air Station Whidbey Island

### 1. **Aircraft Intermediate Maintenance Detachment (AIMD)**

AIMD Whidbey Island provides intermediate maintenance support to 15 EA-6B “Prowler “ squadrons, 6 P-3 “Orion “ squadrons, 12 aircraft carriers, 1 C-9 squadron, the station Search-and-Rescue (SAR) component, and various Northwest Regional activities.

In addition, the sea component<sup>14</sup> provides afloat I-level support by repairing avionics, airframes, power plants, and life support systems for embarking EA-6B squadrons via 22-man team detachments on board 12 aircraft carriers.

The Expeditionary Logistics Unit component of the AIMD provides I-level maintenance and logistics support to forward-deployed expeditionary EA-6B Prowlers at overseas expeditionary sites, and assists other NATO aviation units with maintenance and logistics support by utilizing the unique capabilities of the Expeditionary Logistics Units.

AIMD has a staff of 481 permanently-assigned enlisted Sailors, 13 Marines, 29 civilian personnel, and 213 Sea Operational Detachment personnel supporting all carrier requirements; 190 Van Operational Detachment personnel; and 81 P-3 Operational Detachment personnel supporting the operational requirements of three P-3 squadrons. Additionally, a limited number of temporary additional duty (TAD)

---

<sup>14</sup> The sea component of AIMD is a group of maintenance personnel who pose as regular mechanics when on shore and provide aircraft specific I-level maintenance support for Carrier Air Wings (e.g., a group of aircraft squadrons) when deployed. These personnel accompany the Carrier Air Wing every time it embarks a carrier.



personnel are provided from nondeployed EA-6B squadrons for ALQ-99 Pod Pool maintenance support.<sup>15</sup>

AIMD schedules over 147,000 maintenance actions each year in support of NASWI-based aircraft, deployed aircraft carriers, and various other Naval activities in the Pacific Northwest region.

Roughly 100,000 aircraft parts are inducted, of which 82.5% are repaired and returned to service, while the rest are referred for D-level repair or scrapped. There are 73 work centers that log over 940,000 man-hours of aviation maintenance annually.

AIMD also staffs and manages the Support Equipment Rework Facility at Naval Air Station Everett in support of Pacific Northwest aircraft carriers. In addition to permanently assigned technicians, Navy and Marine Corps Reservists receive mobilization training and contribute to the production effort during drill weekends.

## **2. Aviation Support Division (ASD)**

The ASD is the single point of contact for maintenance activities requiring direct supply support. It is responsible for providing supply support for assigned organizational and intermediate maintenance activities (OMA and IMA). It is where Material Control (MATCON) places requirements for material and equipment needed to support maintenance of weapons systems. MATCON places these requirements by submitting requisitions to ASD.

NASWI ASD provides supply support to the EA-6B and P-3 tenant commands. ASD is comprised of two major sections, the Component Control Section (CCS) and the Supply Response Section (SRS); Figure 1 is a simplified organization chart of an ASD. CCS manages an inventory of over 2,800 line items valued at over \$362 million and processes an average of 2,400 repairable demands

---

<sup>15</sup> Benchmark Publications, Inc., Naval Air station Whidbey Island Website, 2004, retrieved in May 2006 from <http://www.militarynewcomers.com/WHID/Resources/Tenantcommands.html>



monthly. CCS includes Awaiting Parts and Supply Screening units. SRS is the pulse point of ASD, encompassing the Program Management Unit, Preexpended Bin Unit, and the Material Delivery Unit. SRS is responsible for the receipt and delivery of over 4,500 aviation and related support requirements monthly.

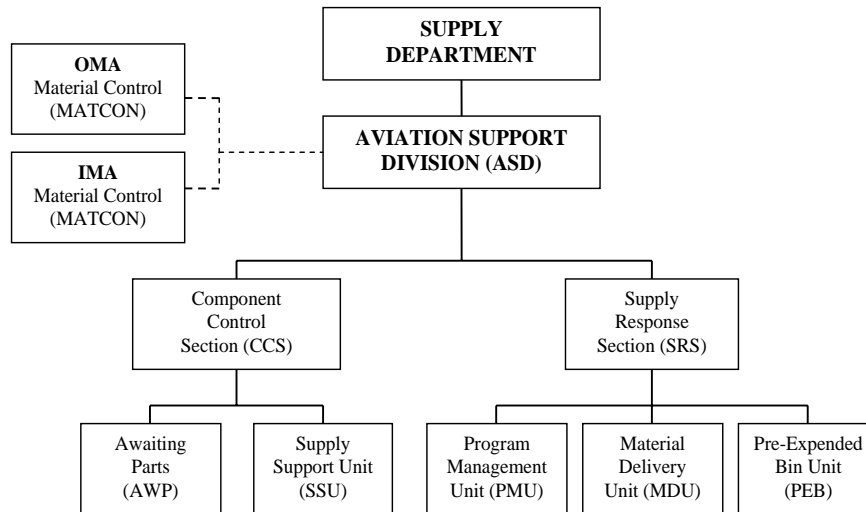

Figure 1. Simplified ASD Organizational Chart.<sup>16</sup>

### 3. Aviation Squadrons

Squadrons are tenant commands assigned to Naval air installations and are referred to in Naval aviation documents as the supported activities, otherwise known as customers. Squadrons are synonymous to OMAs. NASWI supports 15 EA-6B “Prowler” squadrons, 13 of which deploy to aircraft carriers, 4 expeditionary squadrons not assigned to carrier air wings, and 1 Whidbey-based training squadron. With the exception of the training squadron, each deployable or expeditionary squadron consists of an average of four aircraft, each of which has two J52-P408 Pratt and Whitney engines. These EA-6B squadrons are under the leadership of Commander, Electronic Attack Wing, Pacific (COMVAQWINGPAC) that oversees their training operations. COMNAVAIRFOR or CNAF, based in Norfolk, Virginia, manages the total inventory of 366 J52 engines for the Navy and

<sup>16</sup> Department of the Navy, OPNAVINST 4790.2J, *Naval Aviation Maintenance Program*, February 1, 2005, Vol. I, Chapter 18, pp. 18-41.



Marine Corps and directs the repositioning and transfer of these engines to different locations or aircraft, depending on the priority of need.<sup>17</sup>

Similar to AIMD, squadrons are manned with the same mix of aviation technical talents necessary for the upkeep of assigned aircraft. Squadron maintenance personnel are limited to performing only O-level maintenance procedures, which are “on-aircraft” repair such as engine or parts removal and reinstallation, minor aircraft inspection, minor crack repair, etc. Maintenance Control is responsible for the planning and tasking of maintenance operations as well as assigning aircraft to meet the daily flight schedule. Working hours in the squadron vary depending on aircraft availability for the next day’s flight schedule or deployment requirements. Otherwise, EA-6B squadrons operate in two 10-hour shifts on weekdays with a small crew working on weekends.

---

<sup>17</sup> John E. Pike, “J52 Engines,” March 2006, retrieved on July 13, 2006 from <http://globalsecurity.org/military/systems/aircraft/systems/j52.htm>





### III. Literature Review

#### A. Theory of Constraints (TOC)

The TOC, which was created by Eliyahu M. Goldratt, is a body of knowledge that addresses effective management of various organizations as systems.<sup>18</sup> It is a management philosophy and business unit strategy that improves the performance of a system by focusing on its constraints. TOC methodology views organizations as systems consisting of resources, which are linked by the processes they perform (interdependencies). Inherent in such systems are variability in its processes, suppliers, and customers. Within that system, a constraint is defined as any element that restricts the flow of the system. A market, vendor, or an internal resource can be a constraint. Just as the strength of a chain is governed by the weakest link, TOC maintains that the ability of the organization to achieve its goal is governed by the capability of a single or very few constraints.<sup>19</sup>

##### 1. Tenets of TOC

TOC requires a fundamental shift in how an organization is viewed, understood, and measured. To adequately implement TOC requires a five-step, focused approach in order to pursue continuous improvement. These steps include:

- 1) Identify the system's constraint.
- 2) Decide how to exploit the system's constraint.
  - a. Maximize the constraint so throughput is maximized now and in the future.
  - b. Determine what the market values are relative to the industry's current offerings, and align the organization to deliver value as solutions to the market's high-value problems.

---

<sup>18</sup> Thomas B. McMullen, *Introduction to the Theory of Constraints (TOC) Management System*, Boca Raton: FL, St. Lucie Press, 1998, p. 47.

<sup>19</sup> Patrick Hickey, Marcos Da Cruz, and Susie Seaver, "Benchmarking Lean Manufacturing and the Theory of Constraints Implementations," August 2003, p. 2, retrieved in July 2006 from <http://www.cnaf.navy.mil/airspeed/content.asp?AttachmentID=56>



- 3) Subordinate everything else to the above decision.
  - a. Once the constraint has been identified, do not allow the improvement initiatives to interfere with the high priority of the above decisions. Policies, processes, or resources must be altered or managed in order to support the decision to address the constraint.
- 4) Elevate the systems constraint.
  - a. Generate more sales if market is a constraint.
  - b. Acquire new sources for material (vendor constraint).
  - c. Purchase more equipment, hire more employees, reduce setup costs, add additional shifts, etc. (internal resource constraint).
- 5) Decide if the constraint has been broken.
  - a. If the constraint is not broken, return to step 4; if it is, return to step 1.
  - b. Do not allow inertia to become the system's constraints. When a constraint is broken, go back to step 1.

However, prior to the identification of the constraint, it is important to understand the basic facts about the system. Primarily, it is important to know the system and its purpose as well as the measurement of the system's goal. TOC requires the organization to have clear and concise verbalization of its goals because constraints are best identified and dealt with in relation to the system's objective.<sup>20</sup> Additionally, TOC measures if an organization is meeting its goal (in most cases, the goal of making money). It starts by categorizing what a firm does with its money in three ways:

- **Throughput:** The rate at which the organization generates money through sales.
- **Inventory/Investment:** All of the money that the organization spends on things it intends to turn into throughput.

---

<sup>20</sup> Patrick Hickey, Marcos Da Cruz, and Susie Seaver, "Benchmarking Lean Manufacturing and the Theory of Constraints Implementations," August 2003, p. 2, retrieved in July 2006 from <http://www.cnaf.navy.mil/airspeed/content.asp?AttachmentID=56>



- **Operating Expense:** All of the money the organization spends in order to turn inventory into throughput.

The challenge and power of allocating all of the money in the system into one of three mutually exclusive and collectively exhaustive categories lies in the improved ability of the organization to evaluate the impact of decisions relative to the goal of making money.<sup>21</sup>

## 2. Operational Elements of TOC

TOC employs a drum-buffer-rope (DBR) method in its manufacturing process as a means of improving throughput and increasing net profit. The drum is the detailed master production schedule that emerges when demand is matched with the capabilities of the system's constraints. The buffer is the protection allotted to the constraints. This ensures that if disruptions occur in the manufacturing process, work will still be available to the constraint. Rope synchronizes all resources to the beat of the drum by releasing just the right materials into the system, in the right quantity, and at the right time.<sup>22</sup> As such, TOC is essentially a "pull system" that moves the material downstream based on demand. In this case, the beat of the drum is synchronized with the demand. Simply stated, TOC is a key element of the JIT delivery system.

### B. Just-in-Time (JIT) System

There are many things that businesses do to cut costs and keep quality high and JIT is one of the ways that is most often utilized. It is an important process for companies that work around the clock and that use large quantities of parts and other supplies. JIT works by delivering small amounts of needed parts and supplies to a company instead of delivering large bulk quantities.

---

<sup>21</sup> Patrick Hickey, Marcos Da Cruz, and Susie Seaver, "Benchmarking Lean Manufacturing and the Theory of Constraints Implementations," August 2003, p. 2, retrieved in July 2006 from <http://www.cnaf.navy.mil/airspeed/content.asp?AttachmentID=56>

<sup>22</sup> Ibid.



## 1. Advantages

JIT allows companies to operate more efficiently by reducing the amount of material on hand, safety stock, and by eliminating the need for large amounts of money for rent or mortgage on large storage facilities. Utilizing JIT helps many companies keep warehousing costs very low, which in turn allows them to pass these savings on to their customers. Another advantage of using JIT is that it can improve the quality and condition of products delivered to customers, thus avoiding customer-related problems that would otherwise cause difficulties for companies. For example, parts and supplies that sit in warehouses for long periods of time have the potential to get damaged or stop working. Warehouses are often cold, drafty, and leaky places that frequently contain rodents or have other problems. They are usually not well maintained or climate-controlled places. Because of these issues, there is a potential for dust, water damage, rust, extreme heat or cold, and other problems that could damage sensitive parts. On the other hand, there are items that can be stored in warehouses in these conditions and not sustain much damage; however, any delicate or sensitive parts or supplies would likely be easily damaged by adverse conditions. Not only would this slow down production of whatever the company was building with the supplies, but they would need to purchase more supplies to make their orders and get them onto the store shelves in a timely manner.<sup>23</sup> Because of the elements, the cost of manufacturing goods would increase and that cost would very likely be passed on to the consumer. There would also be the disposal costs associated with the damaged parts, which would cause additional labor, transportation, and environmental expenses.

Even in the best of warehousing conditions, many parts that set for a long period of time seem to break virtually on their own. They are made to be used and when they sit idle they can become stuck or otherwise stiffened by long periods of

---

<sup>23</sup> Tim Minahan, "JIT: How Buyers Changed It!" *Purchasing – Boston*, Vol. 121, Iss. 3, September 5, 1996, p. 36.



inactivity. This can cause the same problems that rusting and other issues can cause for a company that is trying to create products.

## **2. Disadvantages**

Chrysler and Ford are two automakers that use JIT for their assembly plants. As long as all of the necessary elements align, JIT is a feasible solution. However, when terrorist attacks were carried out on September 11, 2001, everything came to a halt. Chrysler, Ford, and other countless companies across the country relied on trains, trucks, and airplanes to get parts to their assembly plants; however, following the terrorist attack, United States airspace was closed for several days and virtually everything stopped moving. Road transportation even slowed to a minimum. Although this stoppage did not last very long, it lasted long enough to shut Chrysler down for several hours and Ford down for several days. This event was not only catastrophic and upsetting to companies and those that worked for them, but it also showed how easily the JIT system can fail when things do not run smoothly.<sup>24</sup>

There are obviously pros and cons to the system, as the lack of warehousing and quality problems is certainly important, but the JIT system also works on a very delicate balance that assumes that all traffic, including on the roads and in the air, will run smoothly and on time. There are so many vulnerabilities in the JIT system that it is amazing how many companies still use it; however, when the cost of warehousing and other quality issues are examined, the advantages of JIT more than outweigh the disadvantages.

Despite all of the advantages, after September 11, 2001 companies examined their JIT process closely to determine if it was really in their best interest to continue using it, or if it would be better to find another system of delivery or warehousing that would not require specific timetables for trucks and planes. Since most companies continue to save money and time by using JIT, they will continue to

---

<sup>24</sup> Jeffrey Ball, "Chrysler Averts a Parts Crisis," *Wall Street Journal* (Eastern ed.), New York, NY, September 24, 2001, p. B1.



take the chance that something catastrophic could delay or postpone their incoming inventory. The rewards that they receive from this type of inventory control are worth the risks.

JIT inventory relies on supply chains. Supply chains are vital and important to any business, but they must be flexible and agile to truly be the best that they can be for the customers.<sup>25</sup> The supply chain defines how things get from the manufacturer to the end user, but it also involves how the raw materials that are needed in manufacturing get to the manufacturer. Whoever creates or collects the raw materials is the manufacturer, and the manufacturing company that makes goods from them is the end user of that particular supply chain. What is important, however, is how that supply chain is managed. If it is not managed correctly, there are delays in the production process or there are too many shipments of materials and not enough places to store them, which is why agile supply chains are so very important for any business.

Problems with the production process and problems with materials can be disastrous for any kind of business, because these businesses rely on the idea that they have JIT inventory.<sup>26</sup> This greatly reduces their storage costs, while at the same time ensuring that they always have what they need on hand to continue their work. Both money and time are saved by doing things this way. Managing this supply chain, however, is not always easy, as even small problems can greatly disrupt many different businesses and cost them money and time.<sup>27</sup>

---

<sup>25</sup> Mani K. Agrawal and Minsok H. Pak, "Getting Smart About Supply Chain Management," *The McKinsey Quarterly*, New York: 2001, p. 22.

<sup>26</sup> V.G. Narayanan and Ananth Raman, "Aligning Incentives in Supply Chains," *Harvard Business Review*, Vol. 82, Iss. 11, Boston: November 2004, p. 94.

<sup>27</sup> Hau L. Lee, "The Triple-A Supply Chain," *Harvard Business Review*, Vol. 82, Iss. 10, Boston: October 2004, p. 102.



### 3. Strategy

The lower costs are better for companies, and it is vital that they have the supplies that they need when they need them, especially in times like these where the threats of terrorism and war remain high.<sup>28</sup> External factors can affect any supply chain, whether corporate or military, at virtually any time, so the agility of the supply chain is critical. In order to understand why the agility of the supply chain is so important, it is also necessary to understand a little bit about the marketing strategy of a company.

A firm develops its marketing strategies by first identifying the target market for its products or services. It then develops a marketing mix—a particular combination of product, price, promotion, and place (i.e., distribution and delivery functions in the supply chain) designed to enhance sales to the target market.<sup>29</sup> A unique mix of these elements in a given industry allows firms to compete more effectively, thus ensuring profitability and sustainability. For example, by coordinating various product offerings and associated price discriminations with sales promotions and effective logistics, a firm can increase its sales and profit. Since the Internet has a significant impact on the makeup of this marketing mix, companies should develop strategies that take the unique nature of online marketing into account.

To some extent, the Internet can be used in the supply chain as well, because some companies purchase goods and services that way. Often, they can get these goods and services very cheaply, and more importantly, they can get them quickly. Receiving goods quickly helps the supply chain because it allows for companies to have a fast turnaround, and it also ensures that the companies do not spend a lot of money on storage facilities, because they do not have a large stack of inventory sitting around that they must keep track of, take care of, and work with to sell to others.

---

<sup>28</sup> Mani K. Agrawal and Minsok H. Pak, “Getting Smart About Supply Chain Management,” *The McKinsey Quarterly*, New York: 2001, p. 22.

<sup>29</sup> Mani K. Agrawal and Minsok H. Pak, “Getting Smart About Supply Chain Management,” *The McKinsey Quarterly*, New York: 2001, p. 22.





The Internet also changes the balance of power in relationships with buyers and suppliers by increasing or decreasing the switching costs of these buyers and suppliers. By reducing customers' search costs, the Internet makes price comparison easy for customers, and thus increases price competition.<sup>30</sup> The price competition resulting from lowered customer search costs increases rivalry among existing competitors, reduces switching costs of customers, and thereby shifts the bargaining power to consumers.

On the other hand, information technology reduces menu cost—the cost of administering multiple prices for a number of different products or services—and, in part, facilitates price discrimination. The Internet creates new substitution threats by enabling new approaches to meeting customer needs and performing business functions. World Wide Web technology itself has produced new promotion venues. The Internet also facilitates an electronic integration of the supply chain activities, achieving efficient distribution and delivery. It also facilitates partnerships or strategic alliances by networking partners or allies.

This marketing mix is very important for companies, and the supply chain fits in there clearly. In other words, for most companies, place refers to the supply chain (or value chain). The place aspects of the marketing mix are closely related to the distribution and delivery of products or services.<sup>31</sup> The Internet has significantly changed the way companies' products or services are delivered by reducing transaction and distribution costs, thus helping the supply chain.

One way for companies to differentiate their products from rival companies is faster and more efficient delivery of products to their customers, which also necessitates a more agile supply chain. The Internet allows companies to jump over parts of the traditional supply channel. For example, Dell pioneered the direct-sales approach, eschewing the then-dominant indirect model that interposes a network of

---

<sup>30</sup> Ibid.

<sup>31</sup> Hau L. Lee, "The Triple-A Supply Chain," *Harvard Business Review*, Vol. 82, Iss. 10, Boston: October 2004, p. 102.





distributors, value-added resellers, and retailers between the personal computer maker and the personal computer buyer, and making things much simpler for many people involved with the computer business.

In these complicated times and complex circumstances, however, some businesses are seeing that there arises a need for a third party provider, which is the logistics management firm, as the goal of the supply chain is to link the market place, the distribution network, the manufacturing process, and the procurement activity in such a way that customers are serviced at higher levels and yet at a lower total cost.<sup>32</sup> This is in agreement with the concept of logistics, which is all about gaining competitive advantage in the marketplace.

Today, it has gone beyond that era where the logistics operator has a supply chain from the seller's factory to the buyer's premises. The logistics operators for larger companies that work with the supply chain also do all the packaging, labeling, sorting, customs, documentation, consolidation, collection, and delivery of the supplies.<sup>33</sup> Their systems are generally fully computerized and therefore offer a tracking system and online access to suppliers and buyers alike. This is very important for those that need to keep track of the supplies that they have and the goods that they sell.

As can be seen, having an agile supply chain is very important and very valuable for companies, because they must keep up with their competitors. One of the ways that they can do this is to price things competitively, but they have to be able to do this while still making a profit. If the supply chain that they have is very agile and the companies can use JIT inventory for virtually everything that they do,

---

<sup>32</sup> V.G. Narayanan and Ananth Raman, "Aligning Incentives in Supply Chains," *Harvard Business Review*, Vol. 82, Iss. 11, Boston: November 2004, p. 94.

<sup>33</sup> Ibid.



they will cut costs and therefore will be able to reduce their prices to some extent.<sup>34</sup> The price reduction, in turn, will entice more customers to purchase from them.

JIT inventory is not required for all businesses, of course, but for the larger ones that deal with a great deal of goods, it is almost a necessity. For these businesses, the supply chain is very important, and the agility of that supply chain is what is most crucial. For companies that do not have agile supply chains, they will find themselves struggling with their inventory of raw materials, not being able to react quickly enough to what the market might do and what their competitors might do, and experiencing problems with the amount of goods that they sell and that remain on hand. This could potentially bankrupt a business, and therefore the agility of the supply chain is one of the most critical issues that a business has to deal with in today's global market.

### C. Lean Production

Similar to Little's Law,<sup>35</sup> the concepts used under Lean Manufacturing have been around for years and been applied by operations managers on a regular basis. Lean is a process improvement strategy that focuses on the ability to make everything, everyday, in the exact quantity required, with no defects. The goal is to achieve perfection through the total elimination of waste in the value stream of the process. Lean uses incremental improvement to constantly expose waste to balance operational and standard work flows. Lean is the name used by James Womack in his book *The Machine that Changed the World* to best describe Japan's Toyota manufacturing plant methodology, a.k.a. Toyota Production System (TPS).<sup>36</sup> The word Lean in manufacturing involves eliminating non-value-added processes, which

---

<sup>34</sup> Ibid.

<sup>35</sup> John D. Little published Little's Law in 1961, which simplified the queuing problems that service managers deal with using an assumption-free mathematical equation and theory. The average number of customers in a stable system (over some time interval) is equal to their average arrival rate, multiplied by their average time in the system.

<sup>36</sup> EMS Consulting Group, Inc., "Lean and the Extended Value Stream," 2006, p. 1, retrieved on August 21, 2006 from <http://www.lean-supply-chain.com>



in the history of manufacturing has been applied by many U.S. manufacturers to cut costs and mass produce within a short period of time, long before Lean became popular. The first of such innovations in the United States was the use of templates or patterns in gun-making to make parts interchangeable.<sup>37</sup> The innovation sparked the dawn of the American System of Manufacturing, which was believed to have helped the United States defeat Germany and Japan during World War Two by producing more and bigger war equipment.

After the war, two Japanese engineers, Taiichi Ohno and Shigeo Shingo, began analyzing the American manufacturing techniques to boost Toyota's production amidst capital constraints. Ohno and Shingo improved the American manufacturing processes and tailored it to meet Toyota's needs, which conceived the TPS or Lean Manufacturing.<sup>38</sup>

The Lean philosophy revolves around constant identification and elimination of waste across all activities, from producing the product to its delivery to the end-user.<sup>39</sup> To apply this philosophy, we must first understand how and where to find waste. Ohno identified seven types of waste in the manufacturing process:<sup>40</sup>

- **Overproduction** – Manufacturing an item before it is actually required.
- **Transportation** – Moving products between processes costs time and an opportunity for quality to deteriorate.
- **Unnecessary Inventory** – Work in progress is considered inventory that consumes floor space, increases lead times, and delays identification of problems.

---

<sup>37</sup> Almyta Systems, "History of Lean Manufacturing," 2006, p. 1, retrieved on August 21, 2006 from [http://systems.almyta.com/articles/Inventory\\_Management\\_History\\_7.asp](http://systems.almyta.com/articles/Inventory_Management_History_7.asp)

<sup>38</sup> Ibid.

<sup>39</sup> Patrick Hickey, Marcos Da Cruz, and Susie Seaver, "Benchmarking Lean Manufacturing and the Theory of Constraints Implementations," 29 August 2003, retrieved in July 2006 from <http://www.cnaf.navy.mil/airspeed/content.asp?AttachmentID=56>

<sup>40</sup> David McBride, "The 7 Manufacturing Wastes," August 2003, retrieved on July 10, 2006 from <http://www.emsstrategies.com/dm090203article2.html>



- **Waiting** – Goods that are not moving or being processed.
- **Inappropriate Processing** – Using expensive high-precision equipment that a simple tool can perform. Another example is a floor plan layout where associated operations are located far apart.
- **Unnecessary/Excess Motion** – Involves bending, stretching, walking, lifting, and reaching.
- **Defects** – Defects result in rework and scrap.

The eighth waste has been added in the book, *Lean Thinking*, as **Underutilization of Employees**, which involves underutilization of workers' creative ideas.<sup>41</sup>

The application of the Lean concept begins with the value stream mapping (VSM) process. VSM is a process that lays out the current and future states of the manufacturing system. It forces personnel to ask why things are done a certain way, which uncovers opportunities for improvement in the flow of material and information.<sup>42</sup> Using ideas from personnel at all levels of production, the current state VSM is analyzed, rid of unnecessary “muda,” and streamlined to layout the future state. After the future state has been created, the implementation plan begins through engineering projects or “kaizen” events. Kaizen is a Japanese word that means “change for the better.”<sup>43</sup>

One of the kaizen events employed during the implementation plan of Lean is the 5S Method.<sup>44</sup> This method is the tool used in TPS to organize a workplace. 5S

---

<sup>41</sup> Darren Dolcemascolo, “Seven Wastes of the Extended Value Stream,” EMS Consulting Group, December 1, 2004, retrieved on July 10, 2006 from <http://www.emsstrategies.com/dd120104article1.html>

<sup>42</sup> Darren Dolcemascolo, “Value Stream Mapping,” EMS Consulting Group, February 1, 2005, p. 1, retrieved on August 21, 2006 from <http://www.emsstrategies.com/dd020105article.html>

<sup>43</sup> Patrick Hickey, Marcos Da Cruz, and Susie Seaver, “Benchmarking Lean Manufacturing and the Theory of Constraints Implementations,” August 2003, p. 3, retrieved in July 2006 from <http://www.cnaf.navy.mil/airspeed/content.asp?AttachmentID=56>

<sup>44</sup> Ibid.



represents five activities that begins with S in Japanese and are explained as follows:

- **“Seiri”** – Sorting the necessary from unnecessary items.
- **“Seiton”** – Straightening neatly and labeling items for ease of use.
- **“Seiso”** – Shining or maintaining tidiness at the workplace.
- **“Seiketsu”** – Standardizing or maintaining the first three Ss.
- **“Shitsuke”** – Sustaining adherence to rules and proper procedures.

After organizing the workplace, various operational techniques are used and modified to make the system work flawlessly. Examples of these techniques are:

- **“Poka yoke”** – A Japanese term that means mistake-proofing. It uses techniques that prevents errors from occurring by designing the process, equipment, and tools in such a manner that an operation would not function incorrectly.
- **Visual Control** – Use of visual cues (i.e., lights, markings, etc.) to alert or communicate to everyone a state of normal or abnormal operational conditions.
- **Pull System** – A technique that eliminates the presence of excess spare parts. This is accomplished by only drawing parts from suppliers when they are required. A replenishment triggering system is designed so that parts arrive just in time for installation.<sup>45</sup>

It is important to stress that a successful Lean implementation involves the participation of all employees at all levels of the manufacturing system. Employees must be motivated, empowered, educated, and properly equipped to accept the cultural shift they must undertake in order to arrive at and sustain the desired manufacturing state.<sup>46</sup>

---

<sup>45</sup> Darren Dolcemascolo, “Lean Production Control: Pull Systems,” October 1, 2005, p. 1, retrieved on August 21, 2006 from <http://www.emsstrategies.com/dd100105article.html>

<sup>46</sup> David McBride, “Lean Culture,” July 2004, p. 1, retrieved on August 21, 2006 from <http://www.emsstrategies.com/dm070104article1.html>



TPS turned Toyota around to become one of the largest automobile producers in the world. Today, American companies such as General Motors and Boeing have embraced the Lean Manufacturing System, and have reported major improvements.<sup>47</sup>

#### D. Total Quality Management (TQM)

The origins of TQM come from W. Edward Deming, who is credited with starting a quality revolution in Japan during the mid-1940s. Around that same time period, Armand V. Feigenbaum, who worked at General Electric, was developing quality principles for his organization.<sup>48</sup> TQM concepts became widespread in U.S. organizations during the 1980s.

TQM is simply a customer-focused approach centered on quality. It demands that one knows exactly who is being served, what they need, and why. TQM requires change as a reaction to the needs of the customers. In other words, it champions the belief that continual improvement is possible, the evaluation is necessary, that collaboration is truly essential, and that focus on a particular mission remains critical.<sup>49</sup> TQM is also, out of necessity, based on participation from all of the members that are involved with it and looks ahead to the long-term success through satisfying the customer.<sup>50</sup> When this satisfaction is seen, there are benefits to all of the members in the organization, as well as to customers and society. TQM requires that a company set a quality standard, not just for its products, but in all aspects of the business. Among the issues that must be addressed in TQM is an assurance that things are done correctly initially and that waste and defects are virtually eliminated from all operations. The business must operate smoothly and give the

---

<sup>47</sup> Ibid., p. 8.

<sup>48</sup> William D. Mawby, *Decision Process Quality Management*, Milwaukee, WI: ASQ Quality Press, 2004, p. 39.

<sup>49</sup> Kenneth A. Shaw, "Sunflower Seeds at Syracuse," *The Education Record*, Vol. 74, Iss. 2, Washington, D.C., Spring 1993, p. 21.

<sup>50</sup> William Mawby, *Decision Process Quality Management*, Milwaukee, WI: ASQ Quality Press, 2004, p. 39.



customer a high quality product, when it is needed, in order to ensure customer satisfaction.

## 1. TQM Applications

In companies that deal with manufacturing, quality assurance is usually addressed through various statistical methods. One of the ways that this is done is through a sampling of a completely random selection of product. The sample is tested in areas that have been determined to be significant to potential consumers. Failures that are found are studied until the cause is determined and changes to the design process are not made until the cause is eliminated and the quality of the product is improved.<sup>51</sup>

Manufacturing is not the only area where TQM is used; it is also used in managing accounting systems.<sup>52</sup> Despite these attributes, there were many who believed that TQM was simply a management fad that would not last because many of the management quality ideas appeared to follow a specific life cycle that takes the form of a bell curve. This notion is supported by the peak interest in TQM between 1992 and 1996, after which its popularity declined rapidly in 2000. One reason is that TQM took on different meanings throughout the business world; as a result, not every one felt confident that TQM was truly taking place in accordance with the founding principles of its methodology.

### E. Six Sigma

TQM eventually worked its way into Six-Sigma, or Lean Six-Sigma, which was created by Bill Smith of Motorola during the mid-1980s.<sup>53</sup> Originally, it was defined as a metric that was used for improving quality and measuring defects, and

---

<sup>51</sup> William Mawby, *Decision Process Quality Management*, Milwaukee, WI: ASQ Quality Press, 2004, p. 39.

<sup>52</sup> Ibid.

<sup>53</sup> Praveen Gupta, *Six Sigma Business Score Card: Ensuring Performance for Profit*, New York, NY: McGraw-Hill, 2004, p. 17.





also a methodology that was used in order to reduce the level of defects below 3.4 defects taking place for every one million defect opportunities. In other words, less than 3.4 products, on average, could be defective for every one million produced if everything was working properly in the company. The Six-Sigma approach was designed for the control of defects, but it has since grown beyond that. Now the definition of Six-Sigma is closer to a methodology that is used to manage the variations in processes that cause the defects and are generally defined as the unacceptable deviations that are seen from the target (the mean). The goal of Six-Sigma is to work toward a systematic management of the variation until defects are eliminated from the product, and to deliver reliability, performance, and value to the customer or the end user on a world-class level.

There are many areas of business where Six-Sigma is being used today, and these include insurance, banking, health care, telecommunications, software, and marketing. While Six-Sigma, a trademark and a registered service of Motorola, has saved the company approximately \$17 billion since its inception, other companies have also adopted its approach. These companies include: Cummins, Microsoft, Quest Diagnostics, Siemens, Merrill Lynch, 3M, Lear, SKF, Seagate Technology, Raytheon, Caterpillar, and Ford Motor Company.<sup>54</sup> Additionally, the CEO of General Electric (GE) has been vital in helping with the popularity of the Six-Sigma approach, and has publicly stated that GE uses the Six-Sigma approach and realized a savings of \$300 million in the first year of its implementation.

## 1. Methodology of Six-Sigma

There are two key methodologies that are involved with Six-Sigma—Define, Measure, Analyze, Improve, Control (DMAIC) and Define, Measure, Analyze, Design, Verify (DMADV). DMAIC is used in the improvement of an existing process in an existing business, and DMADV is used to create either new process designs or

---

<sup>54</sup> Praveen Gupta, *Six Sigma Business Score Card: Ensuring Performance for Profit*, New York, NY: McGraw-Hill, 2004, p. 17.





product designs in a way that results in mature, predictable, and defect-free performance for the company.<sup>55</sup>

The basic DMAIC methodology consists of five specific phases—define, measure, analyze, improve, and control.<sup>56</sup> It is important to **define** what the goals are when it comes to process improvement and how these are consistent with both enterprise strategy and customer demands. **Measure** involves a baseline of the current processes so that future comparisons can be made. The third phase includes **analyzing** the relationship between the factors based on causality. The fourth phase includes **improving** and optimizing the process based on the analysis that was created. The last phase includes **controlling** the process capability, the production transition, and future processes. It is also important to ensure that the changes that have been made are continuously monitored so that future variances can be seen and quickly corrected before they are allowed to result in defects.

The DMADV methodology also has five phases, but some are slightly different from those seen in the other methodologies—define, measure, analyze, design, and verify.<sup>57</sup> The **define** step in DMADV is the same as in DMAIC. It is important to **define** the activity design and goals as they relate to the enterprise strategy and customer demand. After which, it is important to **measure** the production process capabilities, the product capabilities, the risk assessment, and other issues. Once this has been completed, one must **analyze** the alternatives for design and create or evaluate different **design** elements until one is chosen. From there, the selected **design** will be developed in detail, optimized, verified, and require some simulation tests to be conducted. The last step is to **verify** the design that was chosen, address some pilot runs, implement the process that was agreed on, and then hand the process over to the owners of the company.

---

<sup>55</sup> Praveen Gupta, *Six Sigma Business Score Card: Ensuring Performance for Profit*, New York, NY: McGraw-Hill, 2004, p. 23.

<sup>56</sup> Ibid.

<sup>57</sup> Ibid.



## 2. Key Roles of Six-Sigma Implementation

The Six-Sigma approach, however, cannot just be implemented without a great deal of dedication toward the process. There are five key roles that must be addressed for a Six-Sigma approach to be successful in its implementation— executive leadership, champions, master Black Belts, Black Belts, and Green Belts.<sup>58</sup>

The first key role, executive leadership, includes not only the CEO, but other top management as well. These individuals are responsible for the actual development of the vision that they will use for the Six-Sigma implementation. These individuals also empower others that have specific roles so that they have the resources and the freedom to explore new ideas and make improvements. The second key role is that of the champions who are charged with the duty of integrating Six-Sigma into the organization.<sup>59</sup> The next level, master Black Belts, are identified and selected by the champions, and they are in-house experts to coach others on Six-Sigma. All of their time is spent on this, and they help assist the champions and guide the Black Belts and the Green Belts. In addition to working with statistics, they also spend time to ensure that the Six-Sigma approach is integrated across all departments and functions. The Black Belts operate under these individuals to make sure that the Six-Sigma approach is applied to certain specific projects. They also devote all of their time to Six-Sigma and generally focus most of their attention on the project execution. The last level, the Green Belts, are standard employees who work on Six-Sigma in addition to the rest of their duties. They work under the guidance of the Black Belts and they help to support them so that overall results can be achieved. There are specific training programs that are utilized to ensure that these people are able to perform properly in their roles. Overall, much of what is used in Six-Sigma is not all that new, but the old tools are used together, and a far greater effort is put into them than what was seen in the past.

---

<sup>58</sup> Praveen Gupta, *Six Sigma Business Score Card: Ensuring Performance for Profit*, New York, NY: McGraw-Hill, 2004, p. 24.

<sup>59</sup> Ibid.



## F. LEAN SIX-SIGMA (LSS)

The Navy's AIRSpeed initiative was developed by merging the "Lean" and "Six-Sigma" methodologies together, the combination of which came to be known as "Lean Six-Sigma." Although these are two different bodies of knowledge, merging them yielded great benefits for the military. Lean focuses on "improving the overall process," while Six-Sigma focuses on "locating and eliminating root causes of the process problems."<sup>60</sup> The successes of LSS led to the implementation of AIRSpeed throughout the Naval Aviation Enterprise as a way to improve cost-wise readiness.

---

<sup>60</sup> Uday Apte and Keebom Kang, "Lean Six Sigma for Reduced Cycle Costs and Improved Readiness," Technical Report NPS-LM-06-033, Naval Postgraduate School, Monterey, CA, 2006, p. 9.



THIS PAGE INTENTIONALLY LEFT BLANK



## IV. Process Description

### A. Overview

Engine removal is categorized as scheduled and unscheduled. Scheduled engine removal is performed on engines that are within minus 10% of an operating cycle or “high-time” (unless granted a waiver by CNAF). The high-time interval for J52 engines is 1,100 flight hours. Unscheduled engine removal is triggered by unplanned events such as engines damaged from foreign object ingestion, unacceptable flight performance parameters, failing oil samples, or characteristics of an internal leak.

### B. SQUADRON ENGINE REMOVAL PROCESS

The engine removal process begins from the time the discrepancy is reported to or identified by the squadron Maintenance Control (see Figure 2). Maintenance Control would direct the Line Division to tow the aircraft from the flight line to the hangar bay. The Aircraft Division would remove and mount the discrepant engine on a mobile or wheeled-engine rack. Removed engines are further stripped of parts that are required to stay with the aircraft. These parts include clamps, oil/fuel lines, constant speed drive generators, hydraulic pumps, air inlet and nose cone assemblies, exhaust pipes, and engine performance wiring harness and connectors. The Administrative Division would perform part and serial number verification of the engine and its associated components to ensure that the part and serial numbers match with the engine logbook records. After the quality assurance inspection, the squadron’s MATCON Division (Supply) would verify the serial number and part number of the engine to match them with the Naval Aviation Logistics Command Maintenance Information System (NALCOMIS) Supply; collect the required logbook records from the Administrative Division; and transfer the engine to AIMD Aircraft Maintenance Screening Unit (AMSU) for induction to AIMD.



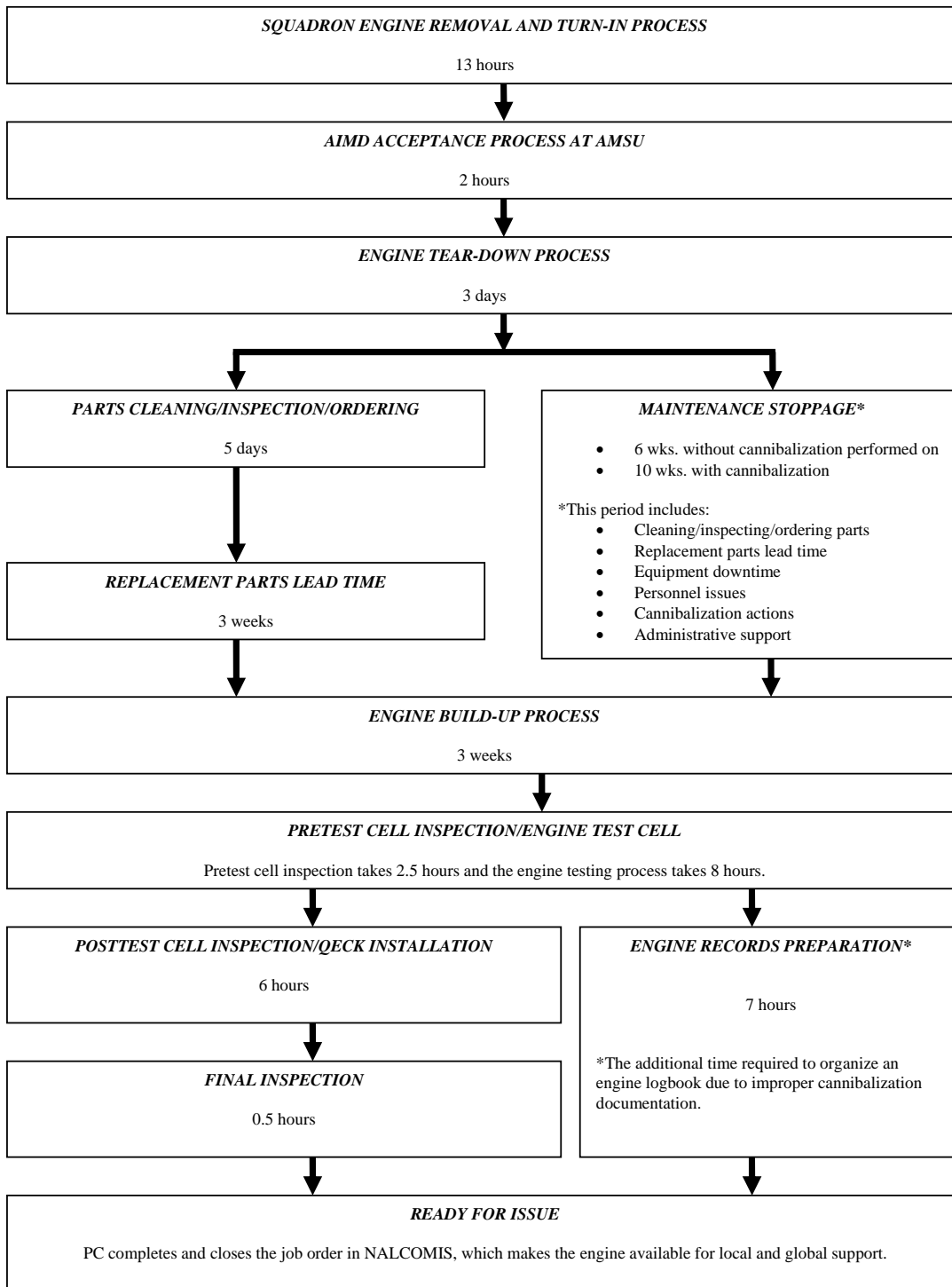

Figure 2. NASWI J52-P408 Engine Repair Flow.<sup>61</sup>

<sup>61</sup> Created by the authors.



The entire engine removal process, from the time the discrepancy is discovered to the time the engine is received by AMSU, takes on average 13 hours, with a minimum of 8 hours and a maximum of 16 hours.

## C. J52 Shop Pre-Airspeed Engine Repair Process

### 1. Screening Process

The screening process begins by assessing whether the engine is within AIMD's repair capability or beyond capability of maintenance (BCM). A collateral duty inspector (CDI) from the J52 Repair Shop performs this function. After the CDI screens the engine, the shop waits for AMSU to induct it for repair or transfer it to a Depot facility if BCM. The screening process normally takes between 1.5 and 2 hours.

Once AMSU inducts the engine for repair, the floor supervisor assigns a repair crew who will be responsible for the repair of the engine from the teardown to the buildup process, a practice known as engine ownership concept. A repair crew normally consists of one CDI (crew leader) and four workers. The same crew may have other not ready for issue (NRFI) engines at different stages of repair waiting to be processed. The crew leader prioritizes which engines should be worked on that day based on the availability of resources. These resources can be personnel, replacement parts from Supply, or parts that can be cannibalized. If the inducted NRFI engine can not be processed, it will be preserved and "cubby holed" (parked) to be repaired at a later time. Cubby holed engines are also used for parts cannibalization to repair other engines. Although engine ownership concept promotes competition, crew sense of pride, and accountability for producing more and good quality engines, it can also easily turn production into a serious state of disarray. Because different repair crews are overseeing multiple engines at various stages of repair, engines and major components are scattered everywhere on the production floor.



Engines inducted for repair are further categorized as either requiring a major engine inspection (MEI) or repair (Quick Fix). MEI engines are disassembled into individual components (nonmodular engine) for a more detailed inspection, while Quick Fix engines are only disassembled as necessary to access areas for inspection and component replacement. Theoretically, the repair processing time of MEI engines is constant, but the variable lead time of replacement parts misleads crew leaders with their prioritization techniques and results in crews migrating from one engine to another. Recognizing the constant processing time of MEI engines is important in determining which prioritization rule should be enforced.

## **2. Tear-Down Process**

The crew leader would log-in to the NALCOMIS computer to put the engine job order In Work (IW), and then other assigned mechanics would log-in to record their start times. A member would then check out a tool box at the Tool Room, where there would normally be a line of other mechanics formed at the counter. After getting issued a tool box, the mechanic would inventory its contents at the site to ensure an all tools accounted for (ATAF) condition as part of the acceptance process. The average time mechanics spend on this process is 0.5 hours and this procedure occurs at a minimum of 12 times per day—at the beginning and end of each shift, and the beginning and end of each job order.

From the Tool Room, the mechanic then returns to the shop, reopens the job order in the NALCOMIS computer, enters the tool box number and his initials to record the ATAF condition, rolls the tool box to the engine location, and reinventories its contents before any engine work can begin. Mechanics would remove only the parts that would lead them to the suspect damaged component or bad engine module and separate these parts between a quick engine change kit (QECK) and non-QECK. QECK is a composite of various categories of hardware, hoses, tubing, clamps, connectors, and small repairable items that are normally replaced during the repair process. QECK parts are placed in small cardboard boxes and stashed in locked 5 x 2 x 4-foot cages (see Figure 3).







Figure 3. QECK Storage.<sup>62</sup>

Non-QECK parts are tagged with the engine serial number and placed on shelves inside the orphanage area (see Figure 4).



Figure 4. Parts Orphanage Area.<sup>63</sup>

While the teardown is in progress, the crew leader orders a replacement for the suspect damaged component or engine module from the NALCOMIS computer. Production Control (PC) assigns a document number under the job order and forwards it to ASD, which then checks if the item on order is available “on station” for immediate issue. If the item is not available on station, ASD forwards the requisition “off station” to be filled by the supply system, and PC assigns the job order an awaiting parts (AWP) status until the part is received. Partially disassembled engines in AWP status are preserved and parked at the NRFI section of the shop and become sources for cannibalization.

---

<sup>62</sup> NASWI AIMD AIRSpeed Office, “400 Before and After,” PowerPoint Presentation, 2006, slide 3.

<sup>63</sup> Ibid., slide 5.

Although the tear-down process would normally last an average of 3 days, a partially torn down MEI engine stays in AWP status at an average of 8 (without cannibalization) and an average of 10 (with cannibalization) weeks.

After the tear-down process, the same crew would spend another 4.5 days on average cleaning and inspecting parts removed from the engine. Serviceable parts are stowed in the orphanage area, while replacements for unserviceable parts are ordered in the supply system. Replacement parts normally arrive within three weeks of placing the part on order.

### **3. Build-Up Process**

The engine build-up process would begin as soon as the replacement item is received from ASD. Similar to the screening process, ASD would ask for a CDI to screen and receive the part. Once PC directs the shop to resume work, the shop would assign a build-up crew to de-preserve<sup>64</sup> the NRFI engine and roll it to the build station. The crew leader would place the job order from AWP in IW status in the NALCOMIS computer, direct someone to perform the tool check-out process, and the rest of the crew would begin gathering the non-QECK components from the orphanage area.

At the orphanage area, crew members would search for items that are tagged with the same engine serial number. Previous cannibalization actions for other engines have often led to misplaced items or items not having been properly retagged. Because of this, depending on the mechanic's familiarity with the part, the search would take an average of 1.2 hours. This includes backtracking documentation in the pass-down book and NALCOMIS, or looking at diagrams in the maintenance manuals. Without using roll-away carts to transfer non-QECK parts and heavy engine components, the crew would have to take several trips from the

---

<sup>64</sup> De-preservation is a process of taking preserved equipment out of prolonged inactivity, storage, or shipment condition for the purpose of verifying or cannibalizing an RFI part.



orphanage area. This operation could take an average of 0.5 hour, depending on the location and accessibility of the engine on the floor.

During the build-up process, quality assurance representatives (QARs) are called upon to occasionally perform in-process inspections. The entire build-up process for an MEI engine would normally take an average of 2.5 weeks, and sometimes up to several months, due to work stoppages caused by late identification of a failed part with long lead time requirements.

The completely assembled engine would be inspected by the floor supervisor, followed by the QAR who would approve the engine as ready-for-test (RFT). This process would take an average of 2.5 hours to complete. After the inspection, it would be moved to the local engine test facility, where it would be leak-checked and tested to see if it meets flight condition parameters. The test would take an average of 8 hours.

After passing the test, it would be moved back to the shop for a posttest inspection and the installation of the QECK. This process would take an average of 6 hours to complete. Consequently, PC would direct the Administration Division to put together the engine records (logbook) for part number verification. Administrative personnel would wait until the engine returns to the shop to perform the physical part verification. Improper document swaps from previous cannibalization actions have caused Administration Division to spend an average of 7 hours to organize an engine record.

After the installation of QECK, a QAR would conduct one final inspection for half an hour and report the completion to PC. Once PC is satisfied with the accuracy of the engine logbook and repair procedures, they would sign off on the completed work order in the NALCOMIS, which completes the engine repair cycle. The RFI engine would then become available to fill any bare firewalls or replenish the engine spares in the Fleet.



#### D. Pre-Airspeed Repair Process Analysis

An analysis of the pre-AIRSpeed repair process revealed many non-value-added steps. Some of the problems were obvious and required only reorganizing the shop and parts storage area. However, some problems required the application of the JIT management, and a First-In-First-Out (FIFO) scheduling systems, transforming the culture of the shop. The following paragraphs describe the changes that AIMD implemented:

- AIMD differentiated MEI from Quick Fix engines based on the variations in repair time and applied the FIFO and Shortest Processing Time (SPT) prioritization methods. The floor supervisor determines the order of engine induction at the NRFI engine waiting line using FIFO and SPT, alternating between MEI and Quick Fix engines. Under this new process, all MEI engines are completely disassembled. Major components are placed at a specific designated location in the shop and this location is well labeled. It is called the Supermarket, for better visibility. The FIFO system is used for building up engines from components prepositioned in the Supermarket area (see Figure 5). The alternating SPT method is used for inducting MEI or Quick Fix engines. FIFO system made the incorporation of buffer and JIT systems more suitable.



Figure 5. Supermarket.<sup>65</sup>

---

<sup>65</sup> NASWI AIMD AIRSpeed Office, "J52 Engine Processing," PowerPoint Presentation, 2005, slide 7.

- AIMD and ASD collaboratively agreed to establish a buffer in the system and adapted the JIT pull system for inventory and production management. After analyzing the system constraints, the AIRSpeed Team established buffer sizes of five spare engines at the RFI section and five subassembly parts at the Supermarket section. Availability of manpower, spare parts, and shop capacity limits the size of buffers that can be introduced in the system. The AIRSpeed Team uses a buffer size of five in the Supermarket because the facility can only accommodate five disassembled engines. ASD produced five sets of consumable and selected repairable parts for the subassembly buffer. The pull system works so that upon drawing an engine from the RFI buffer for global or local support, the crew replenishes it by pulling a NRFI engine from the queue for a Quick Fix repair or teardown, if an MEI engine, while simultaneously building an engine using the subassembly parts from the Supermarket. The buffer system eliminated three weeks' worth of AWP status in the repair process.
- Decentralized its tools and empowered shops to properly account and manage commonly used tools. With the establishment of a small funding account set aside for AIRSpeed implementation purposes, purchasing equipment via the Chain of Command became less painstaking. AIMD furnished the crew with wheeled tool containers for mobility. This reduced the number of trips to tool room down from 6 to 2 times per day, and improved tear-down and build-up process times as shown in Table 1.

Process	Pre-AIRSpeed Process Time in Hours	Pre-AIRSpeed, Process Time in Days (6 hrs/day)	Wasted Hours (4 trips/day)	AIRSpeed Process Time in Hours
	A	$B = A/6$	$C = B*4*5$	$D = A - C$
Tear-down	21	3.5	7	14
Build-up	90	15	37.5	52.5

Table 1. Analysis of the Tool Management System.

- The shop abandoned the single crew engine ownership concept and implemented the formation of a 4-person crew at each stage of engine repair. The crew consists of one inspector, one runner (the most junior), and two mechanics. With the FIFO system in place, there is now a separate crew that cleans, inspects, and orders parts when they are removed from the engine. This new process is done in parallel with the tear-down process, which reduced the cycle time by 4 to 5 days (see Figure 6).



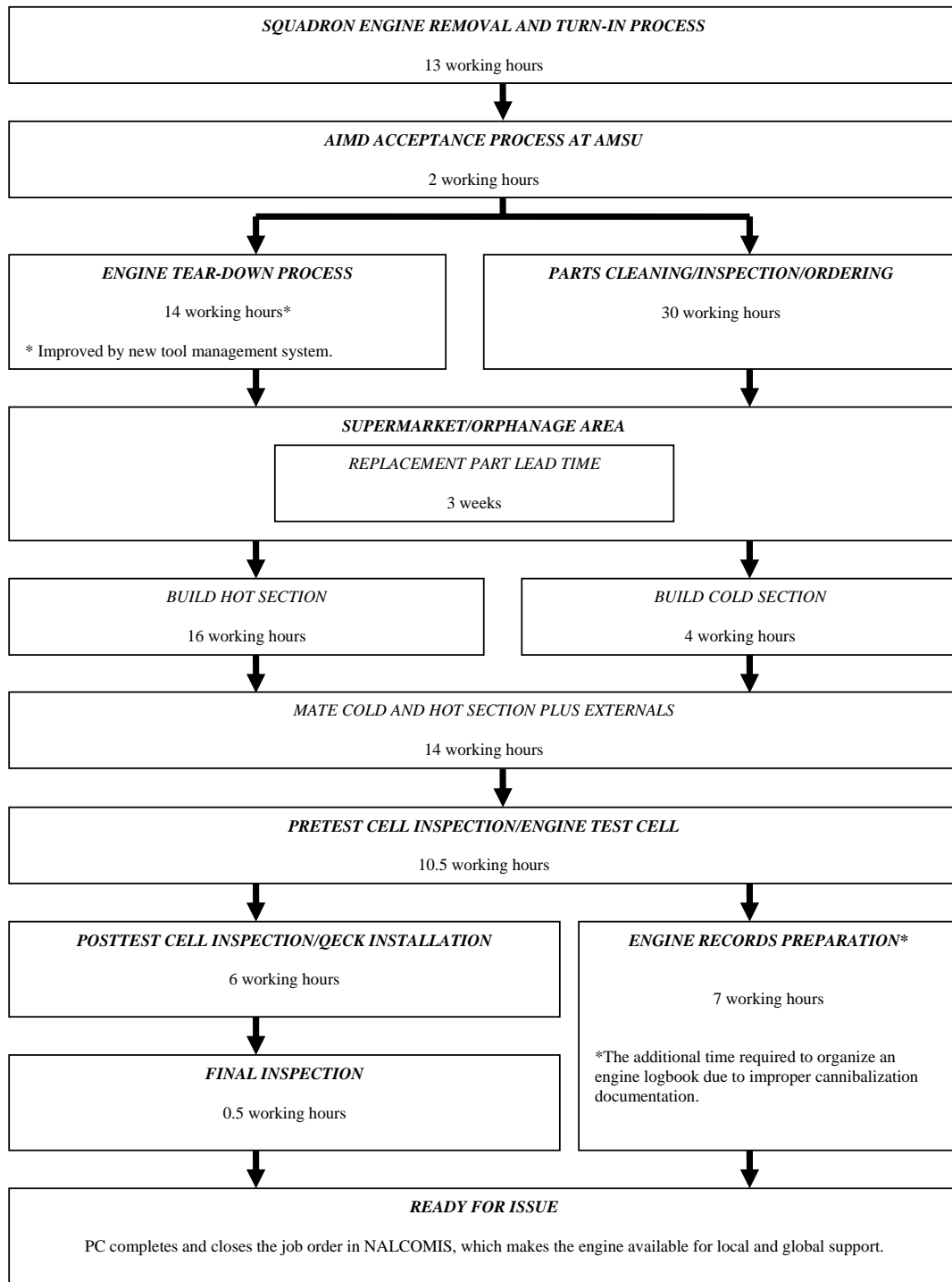

Figure 6. NASWI Improved J52-P408 Engine Repair Flow.<sup>66</sup>

<sup>66</sup> Created by the authors.





- AIMD assigned dedicated QECK, consumable and repairable parts kitting<sup>67</sup> on roll-away carts for each MEI engine (see Figures 7, 8, and 9). For additional accountability, carts are silhouetted to mark where parts are supposed to be placed. Any unfilled silhouette must have a document number that signifies that the part was already ordered in the supply system. This improvement captured two hours into the build-up process.



**QECK Station**



**QECK Tray**



**Left Side**



**Right Side**

<sup>67</sup> Parts kitting is putting together multiple required parts in individual kits for use during the engine build-up phase.

Figure 7. QECK Cart.<sup>68</sup>



Consumable Carts in Orphanage Area



Figure 8. Consumables Parts Kit.<sup>69</sup>

---

<sup>68</sup> NASWI AIMD AIRSpeed Office, "J52 Engine Processing," PowerPoint Presentation, 2005, slides 22 and 23.

<sup>69</sup> NASWI AIMD AIRSpeed Office, "J52 Engine Processing," PowerPoint Presentation, 2005, slides 9 and 32.





**Roll-Away Cart**

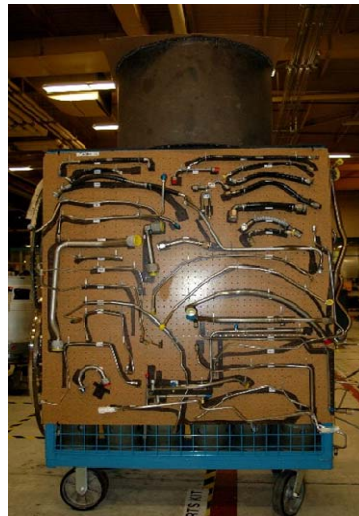

**Back Side**



**Right Side**

**Figure 9. Parts Kit for Cold Section.<sup>70</sup>**

<sup>70</sup> NASWI AIMD AIRSpeed Office, "J52 Engine Processing," PowerPoint Presentation, 2005, slide 8.

## E. Cultural Transformation

Perhaps the most challenging task during the Lean implementation was the handling of the physiological effects on personnel caused by changes in the work environment. These are changes required to eliminate nonvalue shop norms that may seem to pose minor, short-term effects in cycle time, but have greater long-term impact in productivity. These norms are items and practices that provide personal comfort such as long breaks, personal lockers, and lounge areas on shop floors. Changes imposed by AIMD that impacted the working environment included:

- Reorganization of the production floor and removal of non-production-related materials (i.e., stand-up personal lockers, chairs, magazines, etc.; see Figure10).



Figure 10. Crew Break Room.<sup>71</sup>

---

<sup>71</sup> NASWI AIMD AIRSpeed Office, “400 Before and After,” PowerPoint Presentation, 2006, slide 6.

- Shop decking was marked with corresponding stations (e.g., teardown, buildup, Supermarket, QECK, orphanage; see Figure 11).

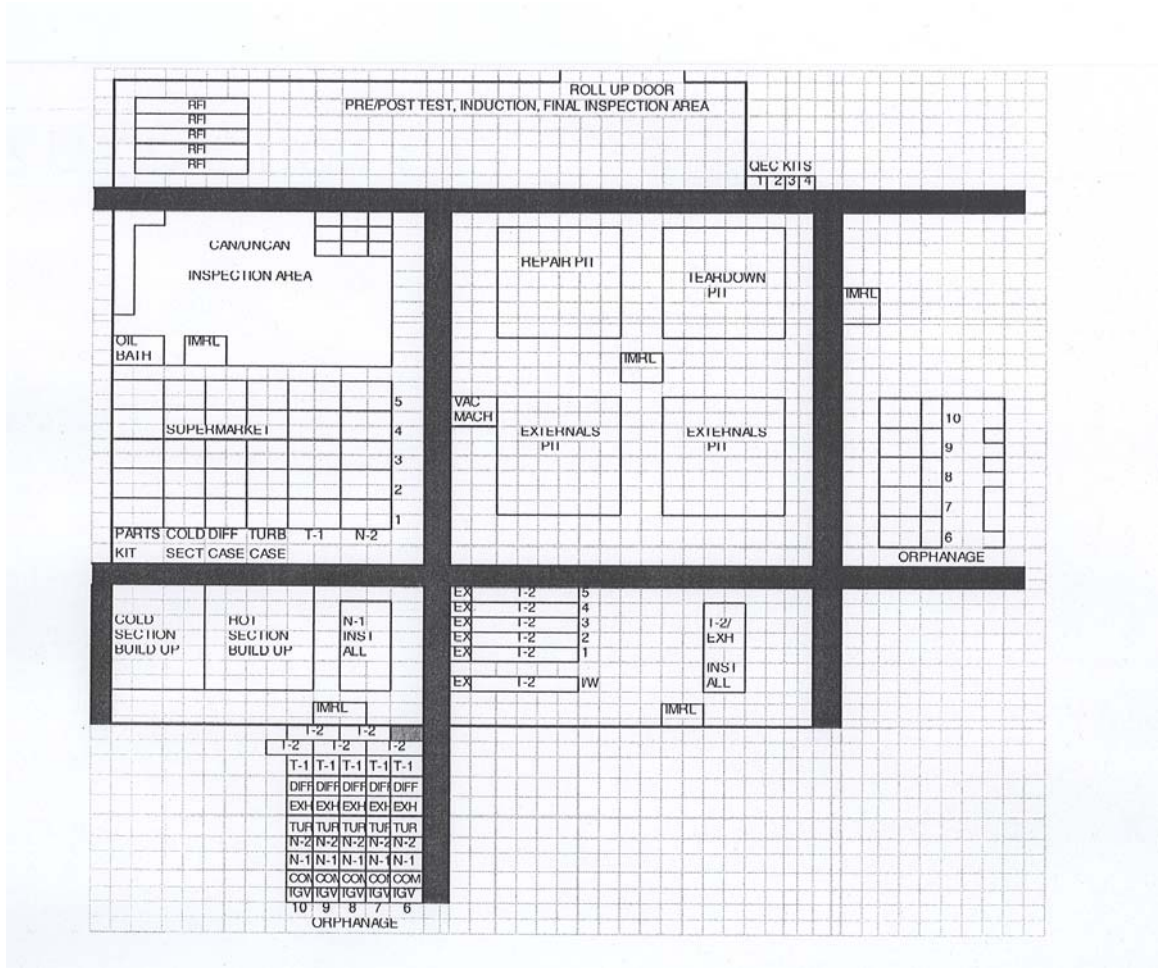

Figure 11. Production Area Designated Stations.<sup>72</sup>

- NALCOMIS production computers were removed from desks and placed on waist-level counters to discourage extended computer use for personal reasons (see Figure 12).

<sup>72</sup> NASWI AIMD AIRSpeed Office, "J52 Engine Processing," PowerPoint Presentation, 2005, slide 5.





Figure 12. NALCOMIS Computer and Technical Manual Stations.<sup>73</sup>

- Personnel breaks were reduced to one hour per shift to capture more work hours per day (e.g., one half-hour for lunch/dinner and two 15-minute breaks).

The AIRSpeed Team knew they would encounter resistance from shop personnel and senior leaders. Without providing education and gaining support from both the crew and the Officer-in-Charge (OIC), any imposed changes would be useless. Nevertheless, because of the nonroutine task structure of the AIRSpeed

---

<sup>73</sup> Photo taken by the authors.



initiative, both directive and participative styles of leadership must be employed in order for it to succeed.<sup>74</sup>

The first resistance encountered by the AIRSpeed Team came from the Power Plants Division Officer, who reacted by protecting his “turf “ and refused to implement some of the changes being imposed in his division. When the OIC became aware of the situation, she reassigned the division officer to another job and placed the resident AIRSpeed officer in charge of the division during the implementation of the AIRSpeed process. The swift and decisive actions of the OIC sent a powerful message to the rest of the repair facility.

Several weeks after changes were imposed, the shop stabilized its production level and did not have to work on engines unless the RFI buffer was less than five. Now that the workload was more predictable, the work schedule was changed from five 8-hour workdays to four 10-hour workdays per week. Stakeholders for the J52 engines and the AIRSpeed program voiced both positive and negative opinions about the new work schedule. Shop personnel enjoyed the extra time off, the ease of locating and ordering parts, and an environment that presents “properly employed” (working) personnel. One civilian mechanic who could not cope with the changes in the traditional work environment was forced to resign from the job. Officers and Chief Petty Officers found the material and production reporting system to be more manageable, while others found that learning the new buffer tracking system was an additional administrative burden.

It is worth mentioning that during the time of the author’s investigative process for this case study, the Prowler community was experiencing major operational readiness uncertainty associated with the grounding of J52 engines caused by oil contamination issues. The accelerated grounding of J52 engines began in

---

<sup>74</sup> Steven L. McShane and Mary Ann Young Von Glinow, *Organizational Behavior: Emerging Realities for the Workplace Revolution*, Boston, MA: McGraw-Hill Irwin, 3rd ed., 2005, p. 424.



September 2005, after filter debris analysis machines<sup>75</sup> (14 Fleet-wide) were found to have been giving off inaccurate wear metal readouts. The machines were taken off-line except for the ones in Pensacola, Florida, where previously conducted oil contamination analysis were sent for retesting. Then, in December 2005, the community ran into numerous contamination failures due to glass bead media, grounding even more engines and causing a “spike” in the NRFI engine induction rate at the AIMD. Engine managers commented that despite the backlog of NRFI engines, AIMD resisted having to work extra hours (Lean), citing insufficient workers to run another shift. AIMD did not adjust the production effort of the J52 shop, maintaining its work schedule of four 10-hour days per week until the end of March 2006, when they began working on weekends. During the authors’ site visit in August 2006, the shop returned to its normal work schedule of five 8-hour workdays per week.

#### F. Site Visits’ Observations

During their first site visit to NASWI AIMD, the authors’ were impressed by the outcome of AIRSpeed implementation in the Power Plants Division. It was evident that there was active participation and strong support from the entire chain of command. Division leaders were knowledgeable and understood the applications of the different AIRSpeed methodologies. Leaders applied both participative and intrusive leadership styles. The AIRSpeed Team displayed focused direction and enthusiasm toward sustaining AIRSpeed and ensured that they understood the process in order to pass on their corporate knowledge to junior personnel. The overwhelming support for AIRSpeed was evident by the buy-ins from key personnel in the chain of command; especially from the top leadership. All enlisted personnel

---

<sup>75</sup> The use of filter debris analysis machines is one of a variety of testing mechanisms authorized by the DoD’s Joint Oil Analysis Program to monitor concentration of wear metals in fluids used to lubricate or power mechanical systems (i.e., aircraft engines, etc.). Department of the Air Force, *Oil Analysis Program*, Air Force Instruction 21-124, April 2003, p. 2, retrieved on September 12, 2006 from <http://www.e-publishing.af.mil/pubfiles/af/21/afi21-124/afi21-124.pdf//search+%22fda%20oil%20analysis%22>



working in the J-52 Engine Repair Shop could, at that time, brief the authors on exactly how the process worked, precisely what point they were in the maintenance procedure, and the status of any outstanding requisition needed to completion the engine they are working on. The crew was able to meet the first peak demand, which was caused by the glass bead contamination during D-level repair.

It was evident that implementing AIRSpeed brought forward some dramatic improvements for the J-52 Engine repair shop. The AIRSpeed program contributed the following enhancements to the repair process:

- Provided clarity for organizational direction
- Streamlined logistical support
- Shortened the lead time for parts
- Improved morale
- Removed non-value-added processes
- Increased work space capacity
- Fostered continuous improvement

On the follow-up visit to AIMD, the attitude of the personnel and the climate in the J52 Engine Repair Shop were different from the authors' observation during the initial site visit. The authors discovered that a change in leadership positions had occurred in the AIRSpeed office and the Power Plants Division. The authors also observed differences in management style between the previous and the current administration. In addition, the authors discovered that, aside from the oil contamination problem, J52 engines were being prematurely removed from the aircraft and forwarded to I-level maintenance for repair due to a 4.5 bearing failure.

It was apparent that the shop was trying to adapt to a higher workload to keep up with the influx of engines in order to satisfy the Prowler fleet's demand. In doing so, some of the pre-AIRSpeed shop practices were reinstated. This unforeseen demand also caused some of the rewards gained during concept implementation to be removed; e.g., the four-day work week.



Strong leadership is the catalyst in promoting and sustaining an environment that adheres to a continuous improvement process. In addition, management must apply constant pressure on the new process until it takes hold. This is vital in order to maintain an effective AIRSpeed program.

#### G. AIRSpeed Engine Repair Process

After implementing and streamlining the necessary changes, the AIRSpeed Team arrived at a new process, shown in Figure 13. With a buffer system in place, the shop would not draw any NRFI engine (e.g., MEI or Quick Fix) from the induction line for disassembly or repair, and consequently assemble another unless the system is “triggered.” Issuing an RFI engine from the RFI buffer creates an empty RFI spot that triggers the system to build an engine to replenish it; thus, describing the “pull” system of inventory. The process is further described below:





# NASWI Enterprise AIRSpeed Design Documentation

Work Center 41A, 415 & 418  
4/28/2005

TO-BE Physical Configuration

## J52 "To-Be" Configuration Diagram

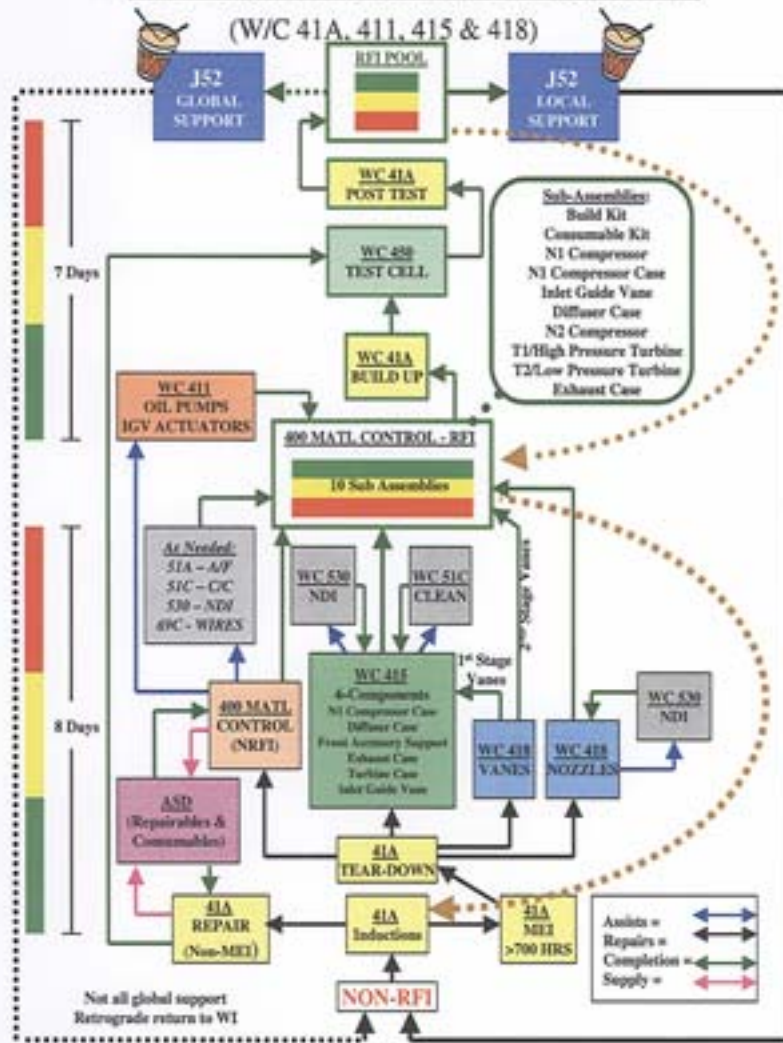

Figure 13. Current Value Stream Map in the J52 Engine Repair Shop.<sup>76</sup>

- A bad engine at the squadron would pull an RFI engine from the RFI buffer.

<sup>76</sup> NASWI AIMD AIRSpeed Office, "Work Center 41A AIRSpeed Report," 2005, p. 5.



- AIMD production control would initiate a job order in NALCOMIS to build an engine and induct an NRFI engine.
- The floor supervisor (an E-6) would form three repair crews to simultaneously build the cold and hot sections<sup>77</sup> of the engine, and teardown an NRFI engine. Each crew consists of one inspector or crew leader, one runner, and two experienced mechanics. One person from each crew would inventory the assigned tool box and roll it to their designated station (e.g., build, repair, or tear-down pits; see Figure 18). The crew leader would enter the rest of the crew in the NALCOMIS, enter his initials for ATAF, and place the job order in IW status (see Figure 19). With the current process in place, times to complete each task are:
  - Four hours to build the cold section of the engine.
  - Sixteen hours to build the hot section of the engine.
  - Two to five days to tear down the NRFI engine.

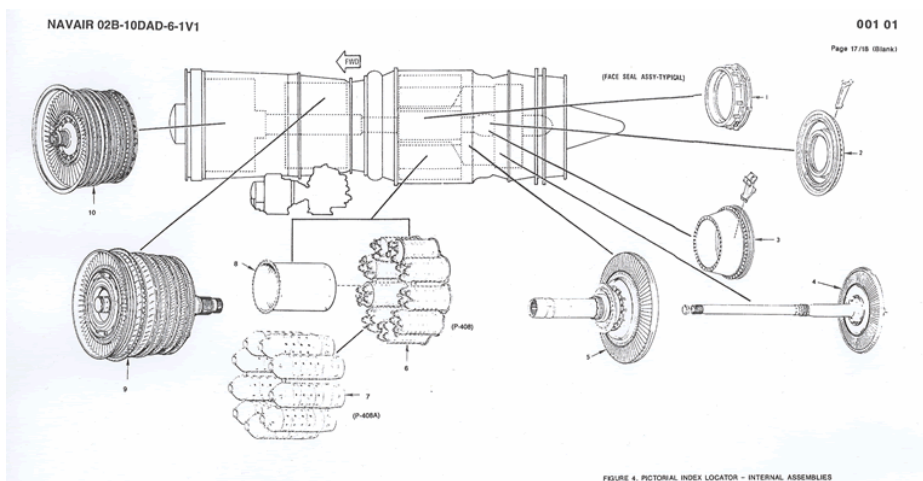

Figure 14. J52-P408 Exploded View of Internal Components.<sup>78</sup>

<sup>77</sup> The cold section consists of the front and rear compressors (see items 9 and 10 in Figure 14 and Figure 15). The hot section consists of the diffuser, combustion chamber, and turbine (see item 5 in Figure 16 and items 5 and 6 in Figure 14 and Figure 17).

<sup>78</sup> Department of the Navy, Technical Manual, *Intermediate Maintenance Aircraft Engines Navy Models J52-P-408 and P-408A/B*, NAVAIR 02B-10DAD-6-1V1. WP 001 01, January 13, 1993, p. 17.



Figure 15. Cold Section.<sup>79</sup>

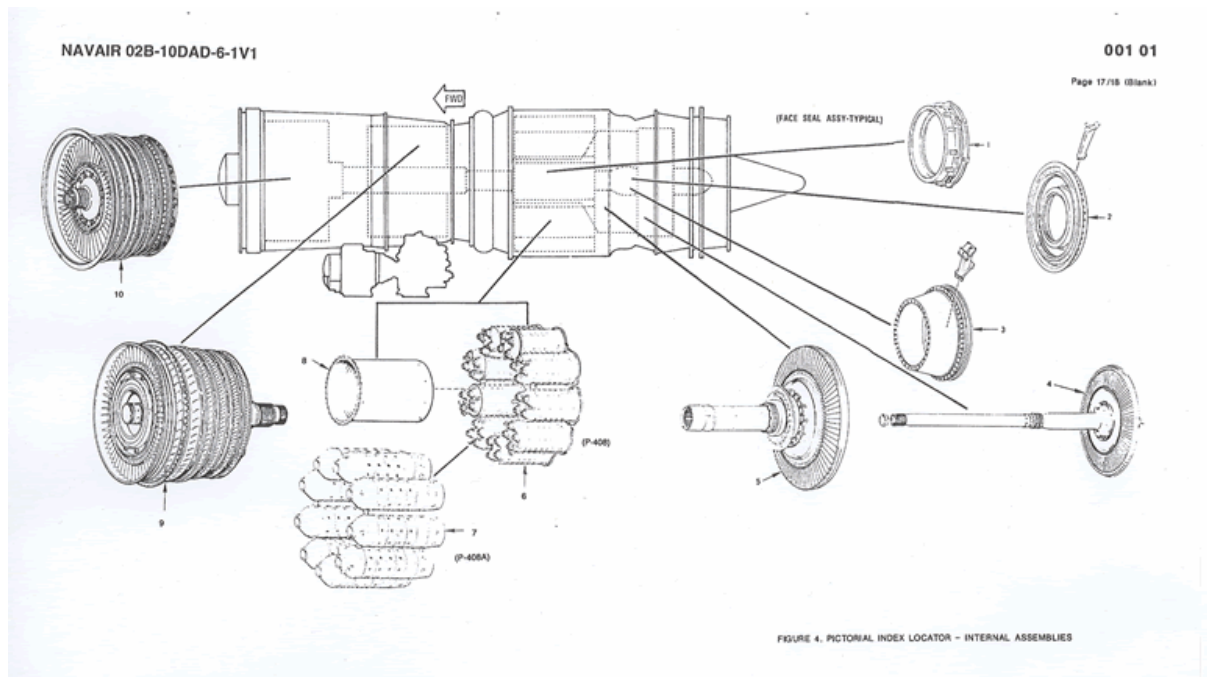

Figure 16. J52-P408 Exploded View of Outside Casing.<sup>80</sup>

<sup>79</sup> NASWI AIMD AIRSpeed Office, "J52 Engine Processing," PowerPoint Presentation, 2005, slide 12.

<sup>80</sup> Department of the Navy, Technical Manual, *Intermediate Maintenance Aircraft Engines Navy Models J52-P-408 and P-408A/B*, NAVAIR 02B-10DAD-6-1V1. WP 001 01, January 13, 1993, p. 13.



Figure 17. Hot Section.<sup>81</sup>

---

<sup>81</sup> NASWI AIMD AIRSpeed Office, "J52 Engine Processing," PowerPoint Presentation, 2005, slide 10.





**Tear-Down Pit**



**Build-Up Pit**

Figure 18. Designated Stations.<sup>82</sup>

<sup>82</sup> Photos taken by the authors.

PRINTED: 06236 1056

**MCN: P9HB54L**

ENTRIES REQUIRED SIGNATURE  
 NONE  LOGS  REC  
 AZZ  K COSTELLO

REMOVED ITEM			ACCUMULATED WORK HOURS					ACCUMULATED AWM HOURS				
DATE REMOVED	NAME/SHIFT	TOOL BOX/INT	DATE	MAN HRS	EMT	DATE	TIME	REASON	HOURS			
	RITTER+3	1 P9H-41A-1	DJG	6111	8.0							
TIME/CYCLE	TIME/CYCLE	TIME/CYCLE										
	RITTER+3	1 P9H-41A-1	DJG	6111	13.2							
	SPURLOCK+2	1 P9H-41A-1	CAS	6114	12.0							
	SPURLOCK+2	1 P9H-41A-1	TEF	6114	10.5							
SERIAL NUMBER												
	RITTER+2	1 P9H-41A-1	DJG	6115	12.0							
CAGE	PART NUMBER											

WUC, TEL, MAL CODE, ACT TAKEN

(H-Z) FAILED/REQUIRED MATERIAL												
INDEX	F/P	A/WP	A/T	MAL	CAGE	PART NUMBER	REF SYMBOL	QTY	PROJ	PRI	REQ NO	DATE REC
	<input type="checkbox"/>	<input type="checkbox"/>										
	<input type="checkbox"/>	<input type="checkbox"/>										
	<input type="checkbox"/>	<input type="checkbox"/>										
	<input type="checkbox"/>	<input type="checkbox"/>										
	<input type="checkbox"/>	<input type="checkbox"/>										

WUC  
23500

FOLD										TECHNICAL DIRECTIVE IDENTIFICATION																	
ACTION ORG	TRANS	MAINT/L	ACT TAKEN	MAL CODE	ITEMS/P	MAN HOURS	ELAPSED MT	INTERIM	F08 CODE	F11 DASH NO	F15 RV	F16 AM	F17 PART	F19 KIT	A48 TYPE EQUIP	A52 BU/SER NUMBER	A59 DISCD	A59 TIM	A60 PUSHT	A82 P/D	A85 SAFE 1/Y/ EI SER	A89 METER	SE MP GR	A74	INVENTORY	F28	
P9H	31	2	C	185	1	0197.7	0062.6	<input type="checkbox"/>							JHPA	678185	H	1									
REPAIR CYCLE					REMOVED/OLD ITEM					INSTALLED/NEW ITEM																	
RECEIVED	B08	05305	B12	1050	B16	E08 MFGR					E13 SERIAL NUMBER					G08 MFGR					G13 SERIAL NUMBER						
IN WORK	B18	06111	B23	0900	B27	E23 PART NUMBER					E30 DATE REMOVED					G23 PART NUMBER											
COMPLETED	B30	06179	B34	0843		E47 PART NUMBER					E43 TIME/CYCLES					G43 TIME/CYCLES											
AWAITING MAINTENANCE										DISCREPANCY																	
MAINTENANCE/SUPPLY RECORD										RECEIVED OFF STATION FROM THE CARL VINSON FOR OIL CONTAMINATION																	
JOB STATUS	DATE	TIME	EOC	CORRECTIVE ACTION																							
IW	06173	1130		PERF 1ST DEG REP(R/R)N2,MGB,FAS,IGV,COMP,DIFF,EXH CASES, #1,2,3,4,4.5,																							
M3	06173	1430		5,6 BRGS, 9 F/N'S IAW NA 02B-10DAD-6-1V1,2,3.																							
IW	06178	0936		CORRECTED BY																							
M3	06178	1056		AD1 C SHOUSE					INSPECTED BY																		
IW	06178	1130		AD1 J OCANAS					AD1 J OCANAS																		
M3	06178	1500		SUPERVISOR					MAINT CONTROL																		
IW	06179	0700		AD1 J OCANAS					ADC A WHITLEY																		
JC	06179	0843		JOB CONTROL NUMBER					UP <input checked="" type="checkbox"/> DOWN <input type="checkbox"/>																		
				A08 ORG					MODEX PRI																		
				P68					TURN-IN DOCUMENT																		
				181 158					5184G899																		
				41A					SYSTEM REASON																		
									678185/MOM																		
									MCN																		
									P9HB54L																		

Figure 19. Sample of a Completed NALCOMIS Job Order.<sup>83</sup>

<sup>83</sup> NASWI AIMD Work Center 41A, retrieved on August 24, 2006 from the NALCOMIS Database.



- Parts removed from the NRFI engine during the tear-down process are immediately transferred to the Component Shop by another runner. The Component Shop would disassemble, clean, process for inspection, order parts that failed the inspection, assemble and then move RFI parts to the orphanage area and the Supermarket. This portion of the process would take between 4 and 5 days to complete. The lead time for parts placed on order is between 2 and 3 weeks. When they arrive, they would be inspected and placed to fill the empty spaces at the orphanage and Supermarket buffers.
- Completed hot and cold sections of the engine are moved and joined together at one of two external pits on the floor (see Figure 20). The same crew that built the hot section would perform this task as well as the remaining tasks leading up to the RFT condition. A detailed process flow of the final buildup is shown in Figure 21. This process would take 14 hours to complete.



Figure 20. Joint Cold and Hot Sections at the External Build-Up Pit.<sup>84</sup>

---

<sup>84</sup> NASWI AIMD AIRSpeed Office, "J52 Engine Processing," PowerPoint Presentation, 2005, slide 14.



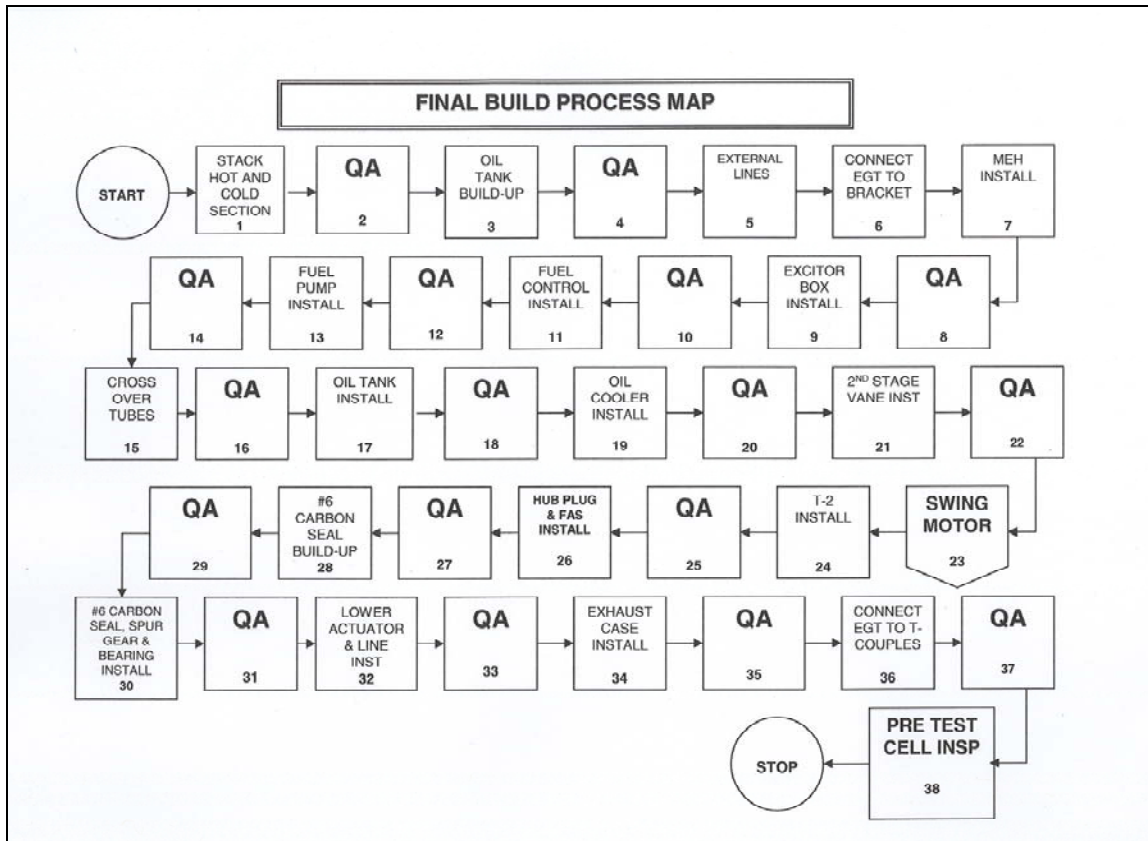

Figure 21. Final Build-Up Process.<sup>85</sup>

- The completely assembled engine would be inspected by the floor supervisor, followed by the QAR who would approve the engine as RFT. This process would take 2.5 hours to complete.
- The engine would be tested at the test cell facility, which takes 8 hours to complete.
- After passing the test cell run, it would be moved back to the shop for a posttest inspection, followed by QECK installation. This process would take between 4 and 8 hours to complete.
- A QAR would conduct the final inspection, which would take approximately half an hour. When the final inspection is satisfactory, PC would sign off the job order in NALCOMIS and the RFI engine would be moved to replenish the RFI buffer (see Figure 22), completing the build-up process.

<sup>85</sup> NASWI AIMD Office, "J52 Process Flow Block Diagram," PowerPoint Presentation, 2005, slide 1.







Figure 22. RFI Buffer.<sup>86</sup>

---

<sup>86</sup> NASWI AIMD Office, "J52 Process Flow Block Diagram," PowerPoint Presentation, 2005, slide 26.

THIS PAGE INTENTIONALLY LEFT BLANK



## V. Simulation Model

### A. Overview

Simulation has a myriad of applications. One of its applications in the production line is to provide management with a tool to evaluate the feasibility of a project without interrupting the physical layout or disrupting the production efforts of an existing process. It helps managers forecast a reasonable outcome of a proposed process improvement over an enterprise that, without simulation, cannot be instantly recognized.

Although simulation has many advantages, it is important to understand that simulation has its limitations. It is this reason that the authors reserve the use of assumptions over some unattainable actual data. Further information regarding simulation model assumptions and limitations will be discussed in Sections C.3 and D of this chapter.

Comparing the pre-AIRSpeed maintenance practice with the present work environment at the NASWI AIMD J52 Engine Repair Shop in Chapter IV provided a good understanding of how AIRSpeed improved the shop's physical appearance and parts visibility through shop reorganization. In retrospect, the readily observable benefits from the new process are insufficient to declare that the NASWI AIMD leadership succeeded in providing the necessary service for the Prowler fleet. In the same respect, logistics issues that the fleet is experiencing are also insufficient to either blame the new repair process as the only cause of the problem or to declare the process a complete failure.

Based on the authors' experience, many beneficial process improvements that Navy units once employed ended up being "scrapped" after their initial implementation periods because of unrelated events or discrepancies such as new administration, renewed priorities, lack of funding, unit resistance, different inspection team grading criteria, etc. The J52 engine repair process improvement



currently in place at NASWI AIMD is no exception for possible termination as it too encountered unit resistance, and received heavy criticism from the community it is designed to serve—the Prowler fleet. The use of simulation will provide critics and supporters alike with an unbiased and justifiable opinion. Therefore, we must evaluate this new process further to examine how it affects readiness, and how it can be improved by constructing a simulation model using the Arena software.<sup>87</sup>

## B. Establishment of Baseline

The authors constructed two sets of simulation models: NASWI AIMD J52 Engine Pre-AIRSpeed Repair Process and the AIRSpeed Repair Process. The model includes NADEP, Marine Aviation Logistics Squadron (MALS) 12, MALS 14, NASWI AIMD, and a generalized<sup>88</sup> flight operation of the Prowler fleet. The model is illustrated in the following figures:

- Figure 23 illustrates the top-level layer of the model, representing the logistics flow of J52 engines.

---

<sup>87</sup> Arena simulation software is a decision-making tool that analyzes a business, service, or non-material-handling intensive production processes. It transforms a process flowchart into a simulation model to visualize a process with animation and to produce statistical outputs for analysis. W. David Kelton, Randall P. Sadowski, and David T. Sturrock, *Simulation with Arena*, McGraw-Hill, Higher Education: Singapore, 3rd ed., 2003.

<sup>88</sup> See Chapter V, Section C.3 (Prowler Fleet Operational Availability) under the “Simulation Model Assumptions” section of Chapter V.



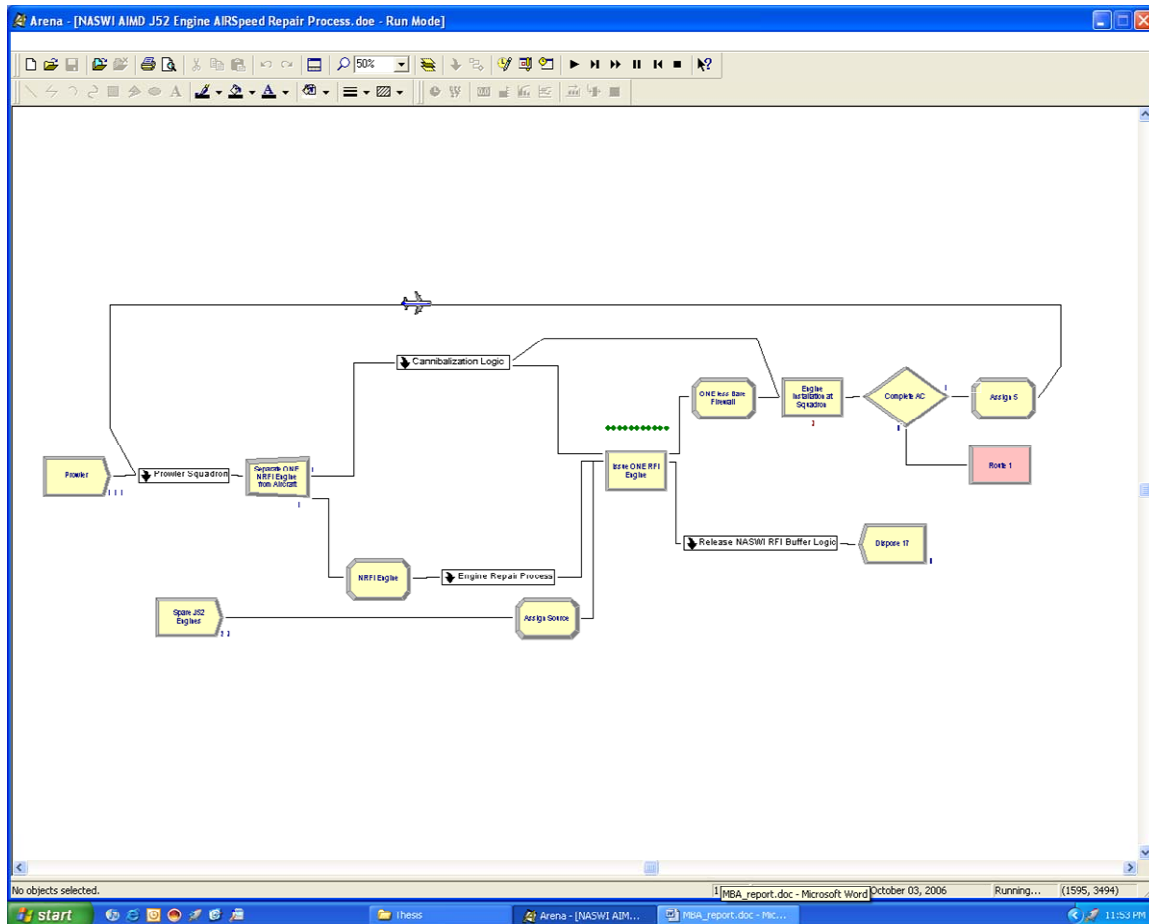

Figure 23. Top-level Layer of the J52 Engine Repair Simulation Model.<sup>89</sup>

- Figure 24 is the submodel that illustrates the relationships of the four engine repair facilities.

<sup>89</sup> Created by the authors using Arena Simulation software.

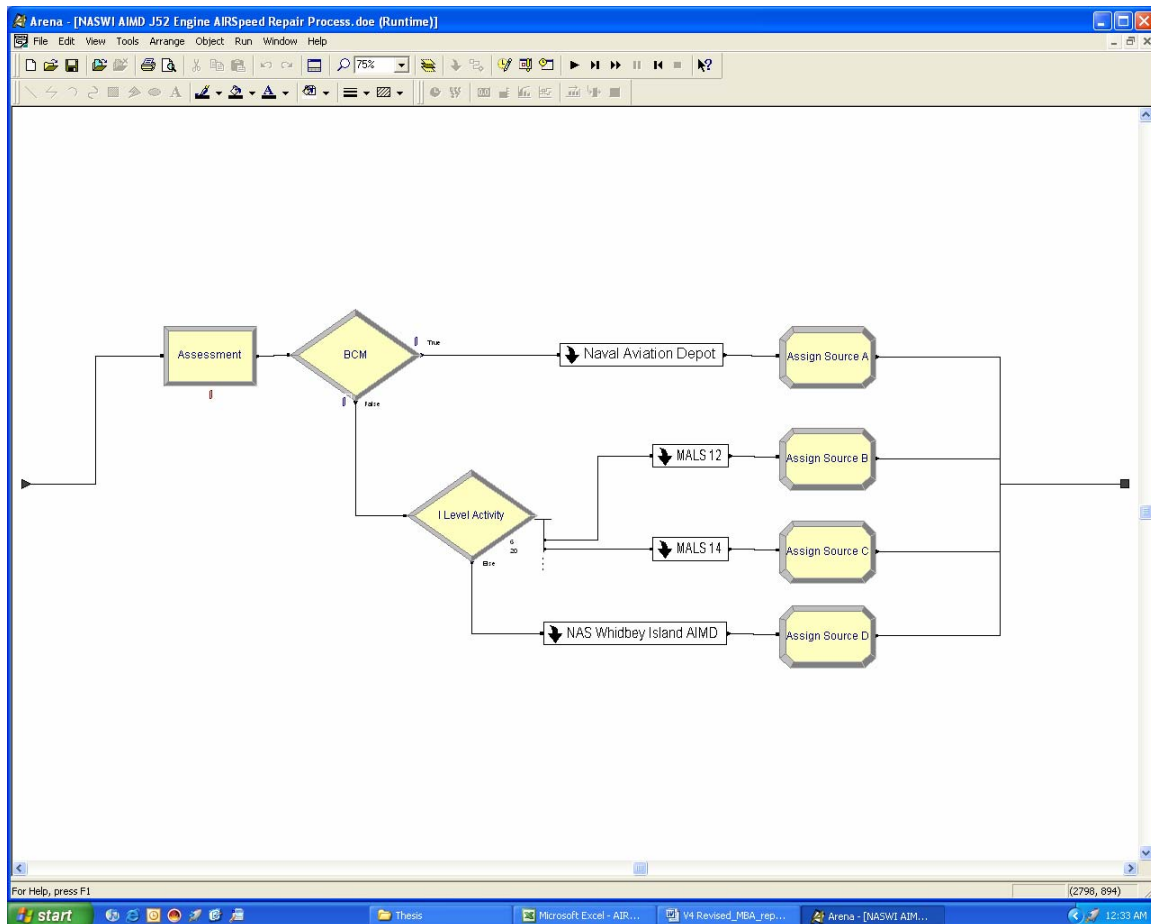

Figure 24. Relationships of J52 Engine Repair Facilities.<sup>90</sup>

- Figure 25 is the submodel that represents the pre-AIRSpeed engine repair process.

<sup>90</sup> Created by the authors using Arena Simulation software.



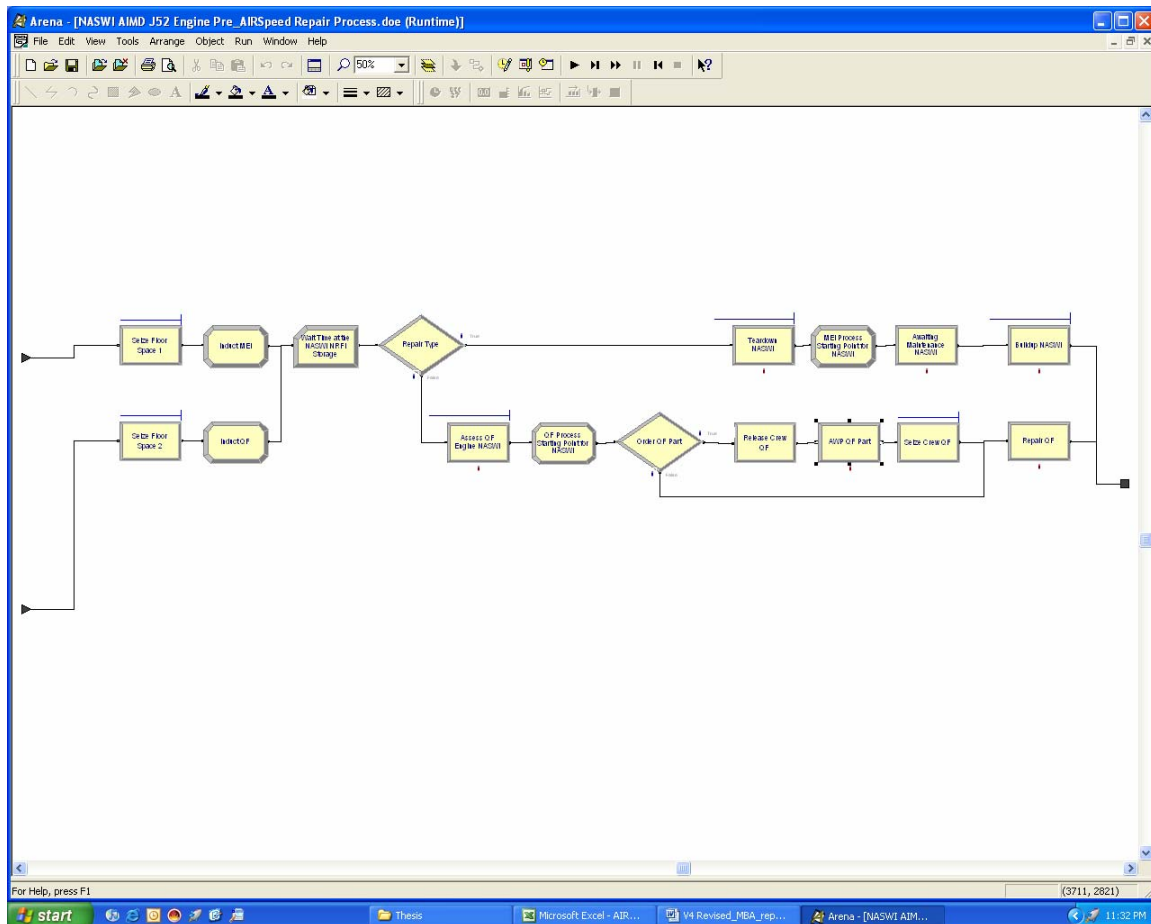

Figure 25. Pre-AIRSpeed Engine Repair Process Submodel.<sup>91</sup>

- Figures 26 and 27 are AIRSpeed engine repair process submodels.

<sup>91</sup> Created by the authors using Arena Simulation software.

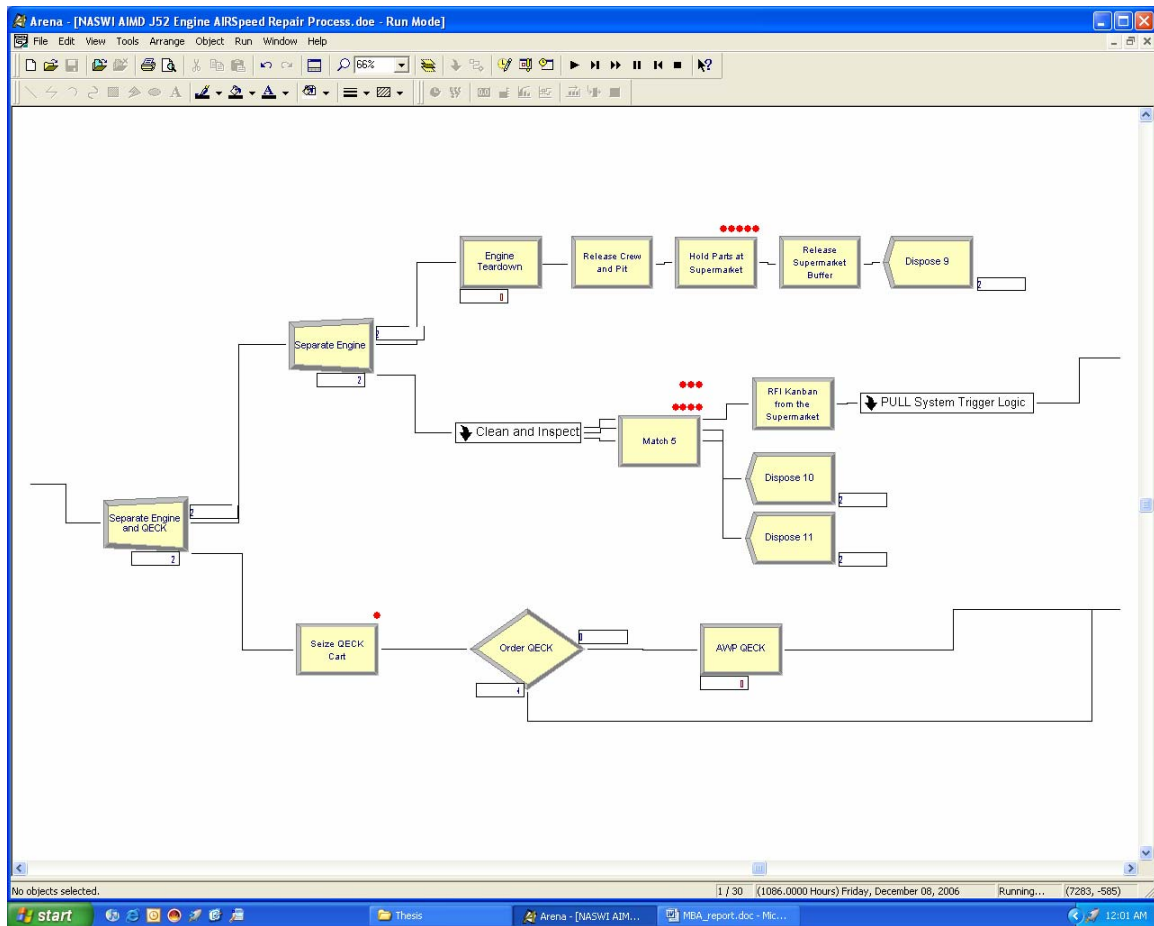

Figure 26. AIRSpeed Engine Repair Process MEI Submodel.<sup>92</sup>

<sup>92</sup> Created by authors using Arena Simulation software.





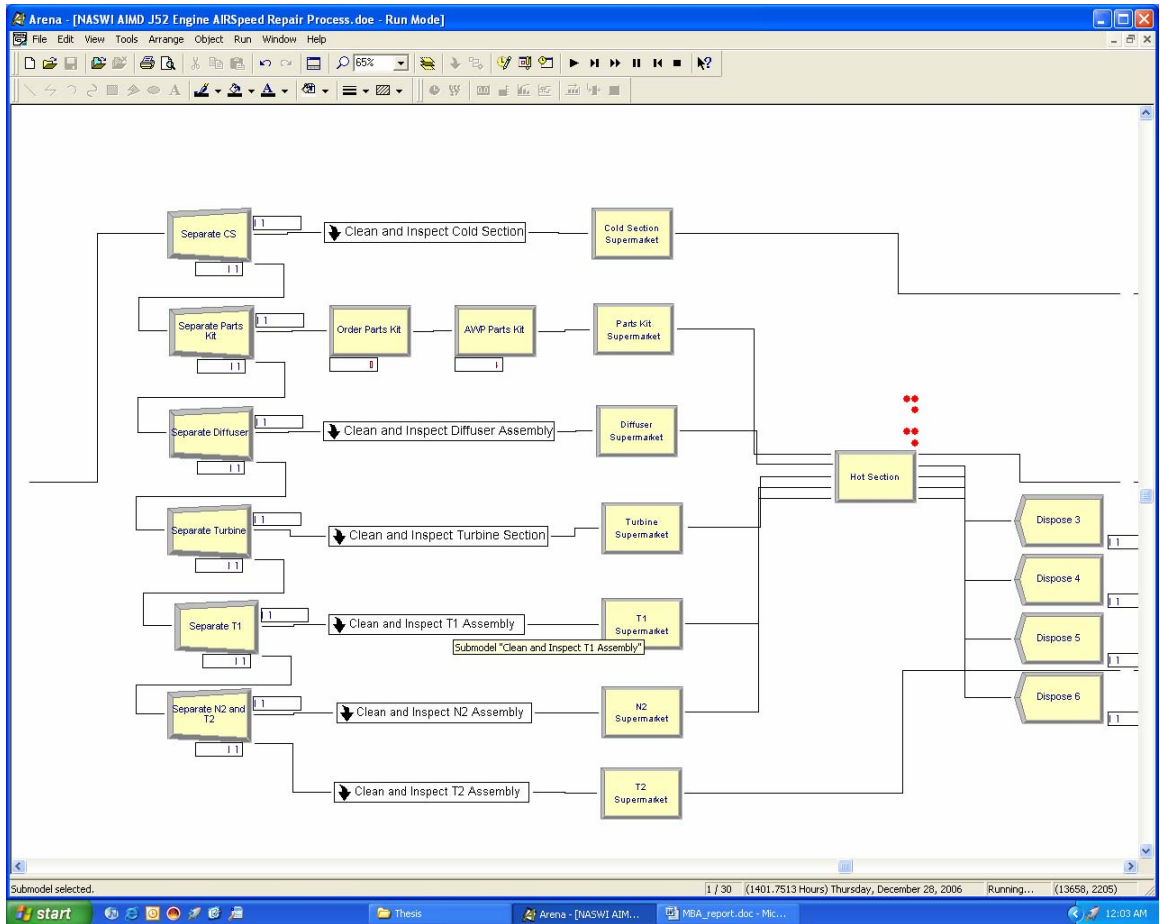

Figure 27. AIRSpeed Engine Repair Process Supermarket Submodel.<sup>93</sup>

The authors established the AIRSpeed engine repair process as baseline scenario for comparing differences between different scenario (embellishment) results. The authors used the parameters described in Chapter IV, Section G (AIRSpeed Engine Repair Process) of this report to build this model. Comparing the results will minimize bottlenecks in the system. The goal is to assist production officers in making sound decisions when options are being proposed. Table 2 provides additional factual data collected during the author’s investigative process of the case.

<sup>93</sup> Created by authors using Arena Simulation software.



EA-6B Average Flight-Hours per Year	262 hours
J52 Engine MTBF <sup>94</sup>	350 hours
Navy and MC EA-6B Aircraft Inventory	111
Installed on Aircraft (two engines per aircraft)	222
Spare J52 Engines (uninstalled)	140
Total J52 Engine Inventory	362
<b>Average Percentage of J52 Engines Repaired at Shore Facilities<sup>95</sup></b>	
NADEP, Jacksonville, Florida	24%
NASWI AIMD, Washington	56%
MALS <sup>96</sup> 12, Iwakuni, Japan	5%
MALS 14, Cherry Point, North Carolina	15%
<b>NASWI AIMD J52 Engine Repair Shop</b>	
Production Hours <sup>97</sup> per Day (Monday through Friday)	7 hours
Repair Crew (consists of one CDI and three mechanics)	7 teams
QARs	6 persons
Component Section Crew (one CDI and one mechanic)	7 teams
Engine Test Cell	2 stations

Table 2. Additional Baseline Model Scenario Parameters.

<sup>94</sup> Department of the Navy, COMVAQWINGPAC, Power Plants Office, "J52 MEFHBR," PowerPoint Presentation, 2006, slide 2.

<sup>95</sup> Department of the Navy, COMVAQWINGPAC, Power Plants Office, "Monthly Production Report," Excel Spreadsheet, 2006.

<sup>96</sup> MALS is an acronym for Marine Aviation Logistics Squadron and is comprised of Marine Corps personnel performing at the same capacity as the Navy's AIMD personnel.

<sup>97</sup> Production hour is the period devoted for physical repair of the engine.



## C. Simulation Model Assumption

The goal of constructing a perfect simulation model that involves input from a wide range of participants in the logistics chain can only be achieved in a constraint-free environment. Constrained by time, the authors resorted to making assumptions on certain areas. The authors made assumptions on data that were not readily available during the investigative process in order to develop a useful model closely resembling a realistic logistics operation of J52 engines in relation to EA-6B aircraft inventory, locations, and current production processes of other shore engine repair facilities. The authors annotated assumed figures in the following areas:

- D-level repair delay time
- Percentage chance that NRFI engines are inducted as MEI or Quick Fix
- Percentage chance that engines or components are candidates for AWP
- Administrative delay time
- Percentage chance that engines are subject for cannibalization
- Cannibalized engine removal and transfer delay time

### 1. J52 Division Management

To achieve a steady system throughout the simulation for comparing results, one of the authors' assumptions is that AIMD management will not deviate from the current engine repair process and will maintain normal production conditions (i.e., working overtime, additional resources, etc.). It is important to note that AIMD once deviated from the current repair process to meet the Prowler fleet engine demands during a period of high engine induction.<sup>98</sup>

---

<sup>98</sup> The Prowler fleet experienced J52-P408 engine malfunction due to oil contamination that led to a high number of premature engine removals for I-level or D-level repair in early 2006.



## 2. MALS and NADEP Engine Repair Shops

Since the investigation concentrated around the jurisdictions of NASWI AIMD and J52 engine managers, the authors formulated additional assumptions regarding the engine repair processes at NADEP and the two MALS. Assumptions regarding these activities are:

- NADEP repairs only engines assessed by I-level facilities as BCM
- MALS 12 and 14 J52 Engine Repair Shops operate under the same pre-AIRSpeed engine repair process at NASWI AIMD described in Chapter IV
- Each MALS 12 and 14 J52 repair shop has three teams of J52 engine repair crews
- MALS 12 and 14 J52 repair shops' hours of operations
  - MALS 12 has 9 production hours per day
  - MALS 14 has 6 production hours per day

## 3. Prowler Fleet Operational Availability

It is important to understand that maintenance down time related to J52 engine maintenance is only a portion of the total accumulated NMC hours for EA-6B aircraft and cannot represent the actual operational availability of the Prowler fleet. The authors strongly suggest that the simulation results on operational availability are not the absolute, but the relative values. However, relative values are useful in demonstrating the increasing or decreasing behavior of the operational availability rate for the purpose of comparing results from multiple simulation scenarios.

To reproduce the absolute or realistic value of aircraft operational availability, the simulation model must be constructed in such a way as to include various events that take place at the aircraft squadron level, thus, affecting flight operations. These events include, but are not limited to, the following:

- Aircraft reporting criteria
- Number of NMC hours related to engine removal



- Aircraft transfers
- Aircraft maintenance schedule
- Squadron deployment schedules
- Training schedules
- Flight plans and schedules
- Maintenance-related aircraft NMC discrepancies other than J52 engines

The authors, constrained by time, were unable to collect the above-mentioned data and had to generalize the Prowler fleet flight operations according to the reported average aircraft flight hours per year of 262 hours. Since not all NMC discrepancies are engine related, the authors made an assumption that only 45% of the accumulated NMC hours per year are caused by engine maintenance.

#### D. Simulation Model Limitations

The construction of the model and the numerical evaluations performed by the simulation model are only as good as the input data that the authors collected during the investigative process. The model is not designed to function as an “intelligent agent,” therefore it only behaves and produces statistical results based on the given sets of condition. Additionally, because the objective of simulation is to mimic the real system’s unpredictable nature, the model generates its own random value, thereby producing a random output.<sup>99</sup> Once again, the model selects the best possible option based on the user input.

Due to the limitations involved during the construction of the model, the authors advise the use of relative values when comparing operational availability rate results from the baseline values.

---

<sup>99</sup> W. David Kelton, Randall P. Sadowski, and David T. Sturrock, *Simulation with Arena*, McGraw-Hill, Higher Education: Singapore, 3rd ed., 2003, p. 8.



E. Simulation Results and Analysis

1. Comparison of Pre-AIRSpeed and AIRSpeed Repair Processes

The authors ran the pre-AIRSpeed and the AIRSpeed models for 30 replications and arrived at the statistical results shown in Table 3 and illustrated in Figure 28. Based on the comparative results, the current AIRSpeed process produced both favorable and unfavorable outcomes.

Embellishments	Supermarket Buffer Size	Engine Repair Space or Work in Progress (WIP)	Repair Crew Utilization Rate	Avg. Engine Repair Cycle Time (days)	Ao	Avg. Time NRFI Engines Spend at the NRFI Waiting Area (days)
Pre-AIRSpeed	N/A	25	64%	35	85%	36
AIRSpeed (Baseline)	5	N/A	33%	12	69%	84

Table 3. Pre-AIRSpeed and AIRSpeed Models Results.



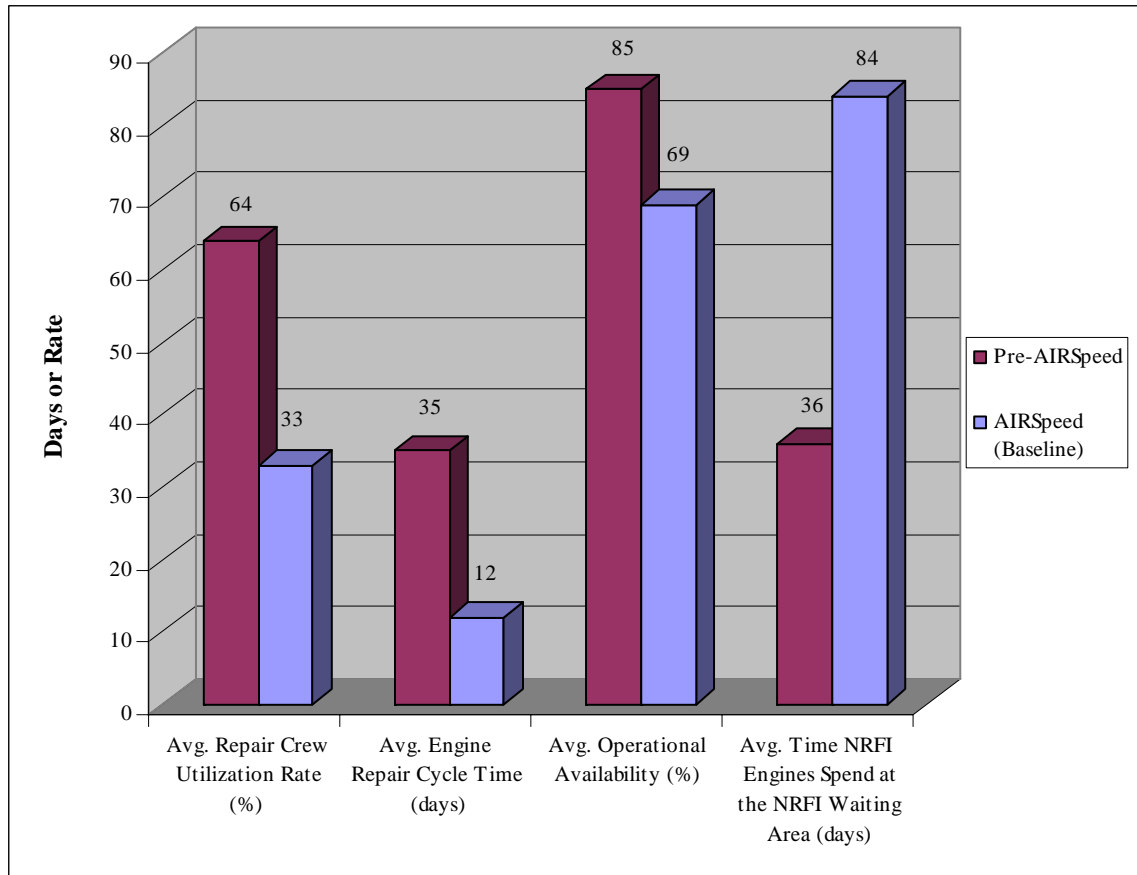

Figure 28. NASWI AIMD J52 Engine (Pre-AIRSpeed and AIRSpeed) Repair Process Comparison.<sup>100</sup>

Favorable results include:

- Shorter average repair cycle (turnaround) time. With the new process, AIMD can put together and produce a RFI J52 engine at a faster rate.
- Lower shop personnel utilization rate. The new process increased the capacity of personnel, which means that they are now able to produce more efficiently when asked to produce at the same level of output.

Unfavorable results include:

<sup>100</sup> Created by authors using Arena Simulation software.





- Longer wait time for NRFI engines at the NRFI staging area prior to induction.
- Lower operational availability.

## 2. AIRSpeed Process Analysis

Figure 29 represents a section of the baseline scenario statistical results. Based on these results, there is a 95% probability that NASWI AIMD will repair between 71 and 102 RFI engines per year under the AIRSpeed process and under the given set of conditions and assumptions. Repairing that many engines constitutes utilization rates of shop resources in AIMD, as shown in Table 4.

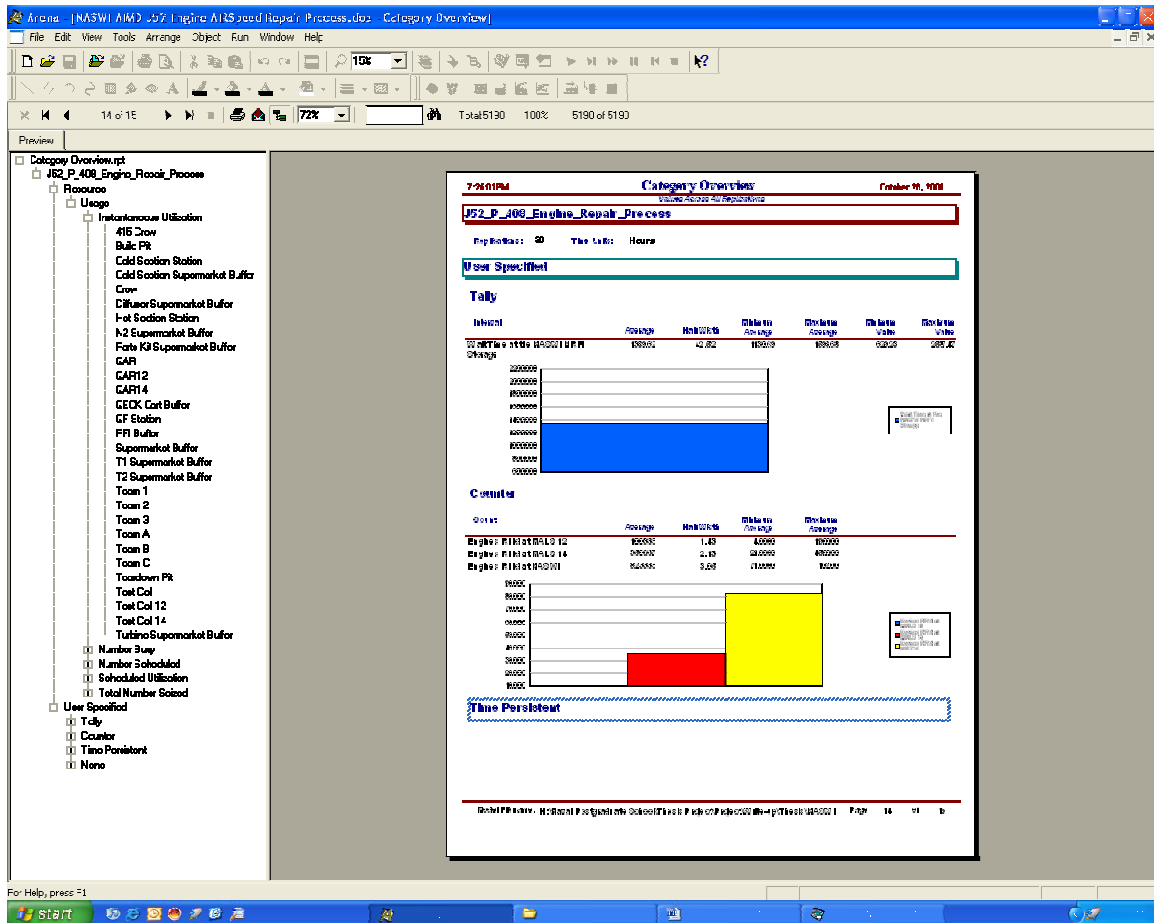

Figure 29. Sample of Baseline Scenario Category Overview.<sup>101</sup>

<sup>101</sup> Created by authors using Arena Simulation software.



<b>Resources</b>	<b>Utilization Rate</b>
Repair Crew	33%
Component Clean-Up and Inspection Crew	67%
QAR	2%
Quick Fix Repair Station	100%
Tear-Down Pit	100%
Test Cell	17%
Build-Up Pit	11%
Cold Section Build Station	12%

Table 4. Baseline Scenario Resource Utilization Rate.

**a. Analysis One**

Figure 30 compares the average engine repair (MEI and Quick Fix) cycle times during the pre-AIRSpeed and AIRSpeed processes. Under the AIRSpeed process, AIMD reduced the average engine repair cycle time from 35 days down to 12 days. Additionally, AIMD can process an MEI repair, from time of induction to RFI status, on average of 16 days or 112 total production hours.<sup>102</sup> This figure far exceeds AIMD’s projected engine turnaround time of 233 hours, which proves that the AIRSpeed process is working in AIMD’s favor. The average repair cycle time to process a Quick Fix engine remained the same at 4 days.

---

<sup>102</sup> Calculated as 16 days x 7 production hours per day = 112 total production hours.



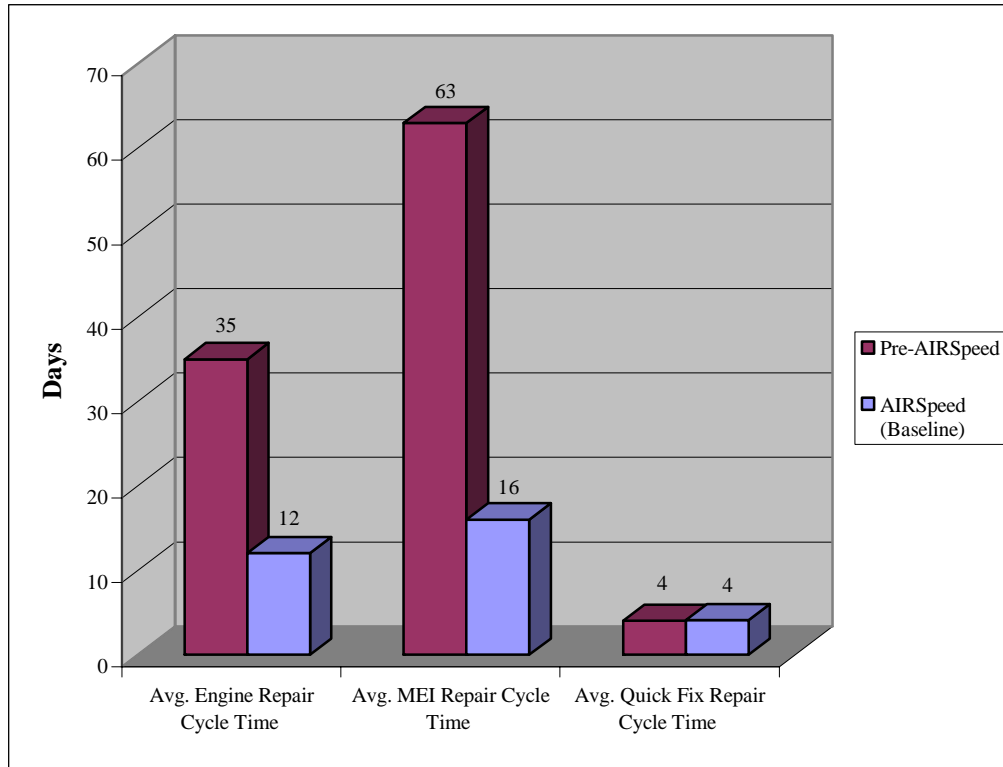

Figure 30. Comparison of Engine Repair Cycle Times.

**b. Analysis Two**

Figure 31 illustrates the maximum wait time and maximum quantity of J52 engines at the NRFI staging area.<sup>103</sup> Under the AIRSpeed process, a NRFI engine will wait at the NASWI NRFI staging area for as long as 162 days prior to induction, and at one point there will be as many as 125 NRFI engines waiting to be inducted for repair. In contrast, the maximum wait time and quantity of engines at the NRFI staging area under the pre-AIRSpeed process were 84 days and 96 engines, respectively. Additionally, the average waiting time of engines at the NRFI staging area is 84 days, compared to only 36 days under the pre-AIRSpeed process. These results favor the criticism by the Prowler fleet regarding their claim that the new

<sup>103</sup> These values are derived from the maximum and average statistical values produced by simulating the J52 Engine Pre-AIRSpeed and AIRSpeed Repair Process Simulation models' 30 replications.



process at the NASWI AIMD J52 Engine Repair Shop is not producing enough RFI engines to fill their bare firewalls.

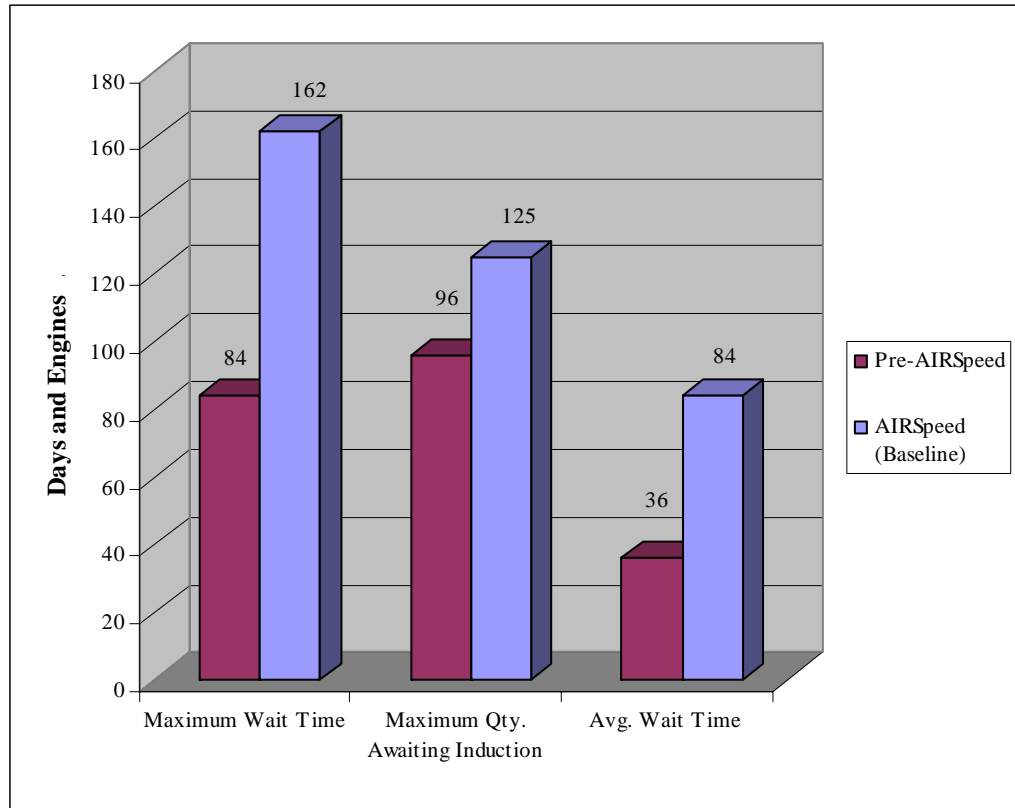

Figure 31. Engine Quantity and Time Spent at the NASWI AIMD NRFI Staging Area.

**c. Analysis Three**

Analyses Two and Three suggest that even though AIMD is repairing engines at a more efficient and much faster rate under the AIRSpeed process, NRFI engines stay on station longer than before. A closer look at Figure 32 reveals that, not only did MEI engines stay longer on station, Quick Fix engine residence time<sup>104</sup> more than doubled with the new process, which leads the authors to suspect that the Quick Fix Station is the bottleneck in the current process.

<sup>104</sup> Residence time is a period measured from the time the NRFI engine is received at AMSU to the time it is tagged RFI.



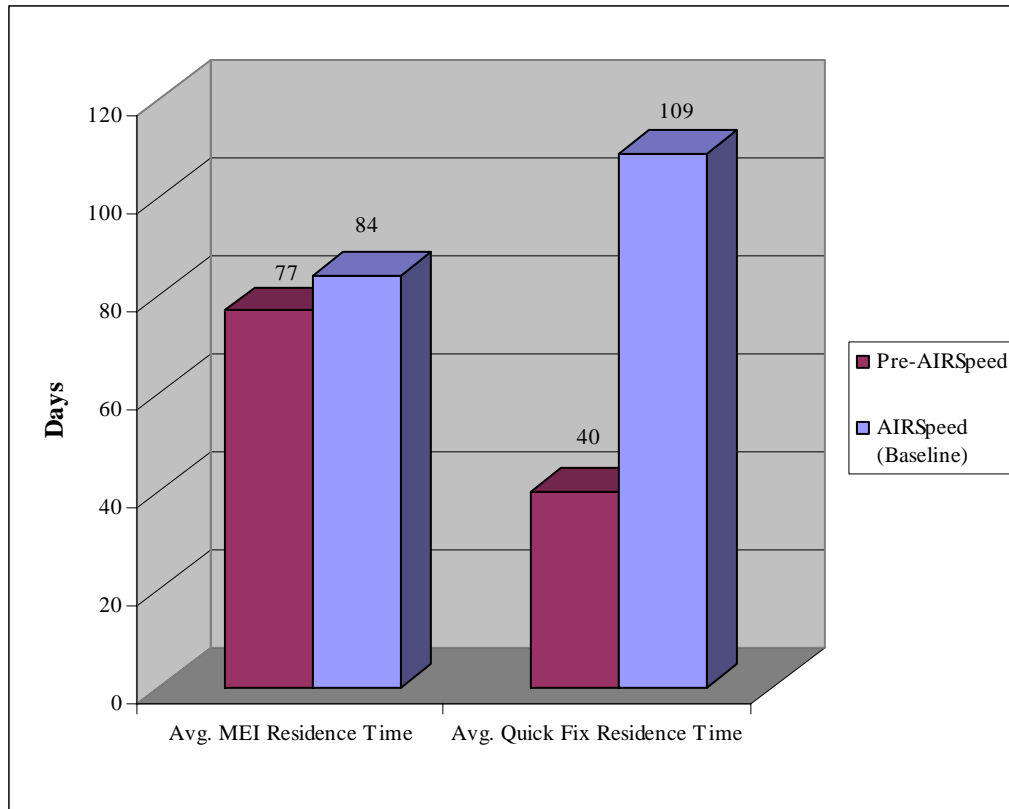

Figure 32. MEI and Quick Fix Engine Residence Time.

**d. Embellishment Formulation**

After considering the Quick Fix repair portion of the AIRSpeed engine repair process as the bottleneck, we can now determine the feasibility of improving the process. This task can be accomplished by developing and analyzing the different embellishment results. Different embellishments were developed by adjusting the quantities of different resources available in the J52 production shop. These resources are manpower (e.g., repair crew and component section crew teams, QARs, etc), Quick Fix Repair Stations, RFI Buffer Size, Supermarket Buffer Size, Engine Test Cell Stations, Tear-Down Pits, Build-Up Pits, and the Hot and Cold Sections. Based on Analysis Three and the utilization rate results in Table 4 (Section E.2 of this chapter), the authors focused on adjusting only the following resources to develop the different embellishments: Quick Fix Repair Stations, RFI Buffer Size, and Supermarket Buffer Size. The embellishments are:



- **Embellishment 1.** Reconstruct the baseline scenario by increasing the number of Quick Fix Repair Station resources up to a quantity of ten.
- **Embellishment 2.** Reconstruct the baseline scenario by increasing the buffer size to 15.
- **Embellishment 3.** Reconstruct the baseline scenario by increasing only the RFI buffer size to ten.
- **Embellishment 4.** Reconstruct the baseline scenario by increasing the buffer size up to 15, while keeping the optimal quantity of the Quick Fix repair station resource from Embellishment 1.
- **Embellishment 5.** Reconstruct the baseline scenario by increasing the RFI buffer up to 15, while keeping the optimal quantity of the Quick Fix repair station resource from Embellishment 1.

## F. Embellishments and Analysis

The authors used the Process Analyzer feature of the Arena software to produce the statistical results for the five embellishments. The results are illustrated below, along with the authors' analyses.

### 1. Embellishment 1 Analysis (Quick Fix Station)

Table 5 shows the results for Embellishment 1. The results confirm the authors' initial suspicion that the Quick Fix station is one of the bottlenecks in the system. Figure 33 illustrates the behaviors of operational availability (Ao) and crew utilization rates as more Quick Fix stations are added in the system. Operational availability increases significantly when more Quick Fix stations are added to the system. Additionally, Figure 33 suggests that the increasing operational availability rate diminishes after the fourth station, which signifies that the optimum quantity of Quick Fix stations is four.



Embellishments	Supermarket Buffer Size	RFI Buffer Size	Quick Fix Repair Station	Ao	Repair Crew Util. Rate	Comp. Section Crew Util. Rate	Test Cell Util. Rate	Quick Fix Repair Station Util. Rate	Avg. Qty. of MEI Awaiting Induction	Avg. Qty. of Quick Fix Awaiting Induction	Avg. MEI Residence Time (days)	Avg. Quick Fix Residence Time (days)	Avg. Time NRFI Engines Spend at the NRFI Staging Area (days)
Baseline	5	5	1	69%	33%	67%	4%	100%	38	69	84	109	84
1	5	5	2	79%	36%	62%	5%	100%	46	53	90	91	84
	5	5	3	85%	37%	55%	5%	100%	54	42	96	81	81
	5	5	4	88%	38%	51%	4%	100%	56	35	96	77	78
	5	5	5	86%	37%	49%	5%	100%	59	32	98	75	78
	5	5	6	85%	38%	49%	5%	100%	60	32	98	75	78
	5	5	7	85%	38%	49%	5%	100%	60	32	98	75	78
	5	5	8	85%	38%	49%	5%	100%	60	32	98	75	78
	5	5	9	85%	38%	49%	5%	100%	60	32	98	75	78
	5	5	10	85%	38%	49%	5%	100%	60	32	98	75	78
Baseline	5	5	1	69%	33%	67%	4%	100%	38	69	84	109	84
2	6	6	1	76%	38%	77%	4%	100%	31	71	76	105	75
	7	7	1	77%	39%	79%	5%	100%	26	73	73	103	71
	8	8	1	76%	40%	81%	5%	100%	23	75	67	104	65
	9	9	1	78%	39%	80%	4%	100%	23	73	67	104	65
	10	10	1	81%	40%	80%	5%	100%	19	74	65	103	62
	11	11	1	80%	43%	84%	5%	100%	19	72	61	98	58
	12	12	1	83%	43%	83%	4%	100%	18	71	61	100	57
	13	13	1	86%	43%	84%	5%	100%	14	68	58	96	54
	14	14	1	85%	43%	83%	5%	100%	13	70	56	95	51
	15	15	1	84%	44%	87%	4%	100%	11	70	52	96	47





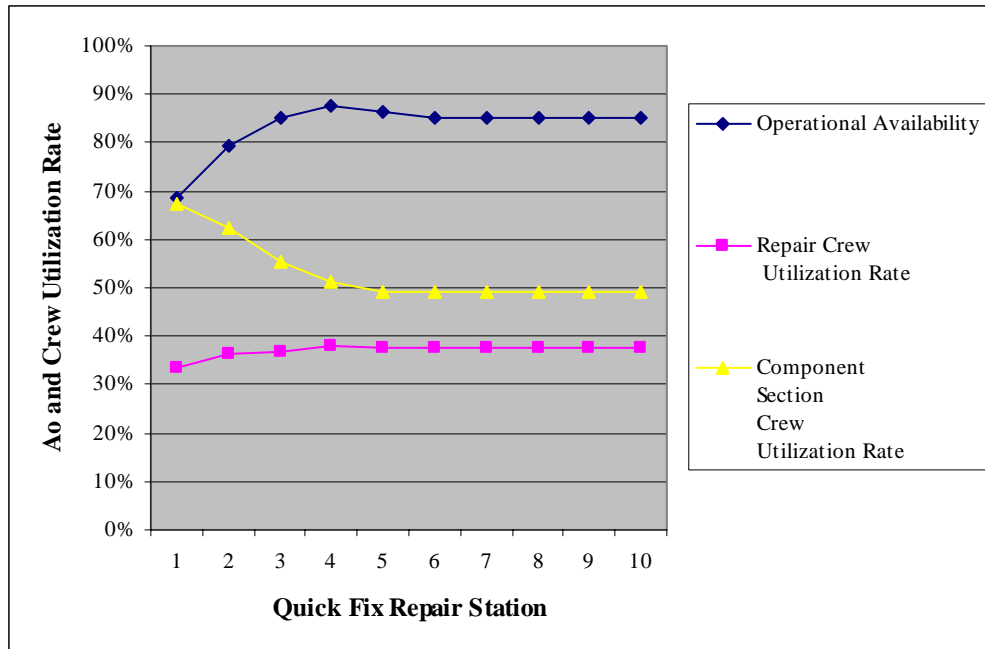

Figure 33. Embellishment 1 Quick Fix Station vs. Ao/Crew Utilization Rate.

Figure 33 also illustrates a significant improvement of crew efficiency at the Component Section, and a slight increase in repair crew usage.

## 2. Embellishment 2 Analysis (Buffer Size)

Table 5 also shows the results for Embellishment 2. Figure 34 illustrates the behaviors of Ao and crew utilization rates as the Supermarket buffer size increases. Increasing the size of the Supermarket buffer will also significantly increase Ao, but diminishes when the buffer size reaches 6 or 7.

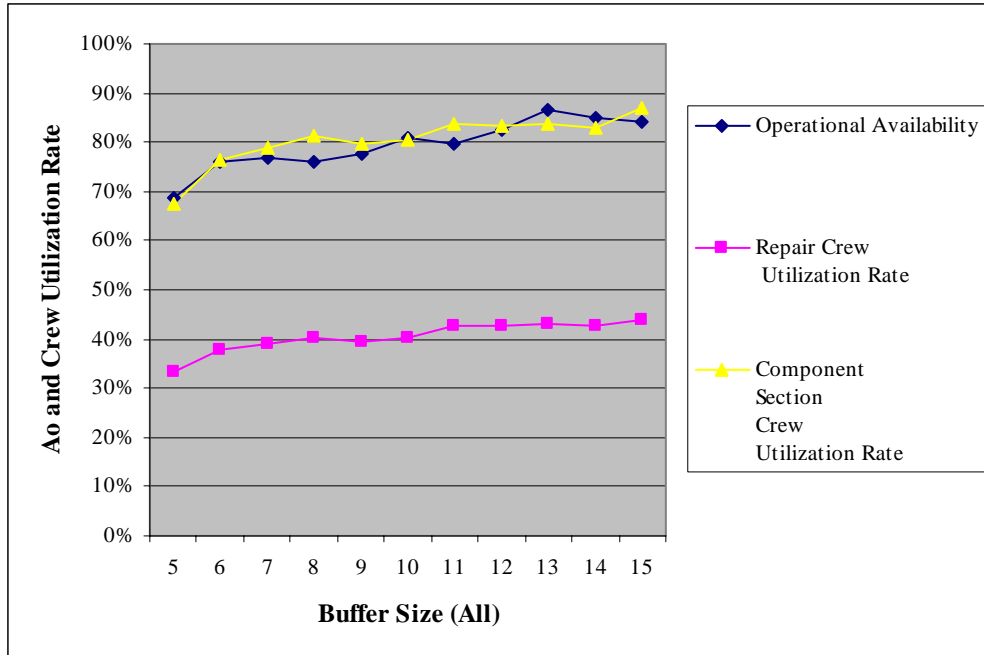

Figure 34. Embellishment 2 Buffer Size vs. Ao/Crew Utilization Rates.

### 3. Embellishment 3 Analysis (RFI Buffer)

Table 6 shows the results for Embellishment 3. Figure 35 illustrates that by increasing only the size of the RFI buffer closely resembles the same effect on Ao as illustrated in the Figure 34 results of Embellishment 2.



Embellishments	Supermarket Buffer Size	RFI Buffer Size	Quick Fix Repair Station	Ao	Repair Crew Util. Rate	Comp. Section Crew Util. Rate	Test Cell Util. Rate	Quick Fix Repair Station Util. Rate	Avg. Qty. of MEI Awaiting Induction	Avg. Qty. of Quick Fix Awaiting Induction	Avg. MEI Residence Time (days)	Avg. Quick Fix Residence Time (days)	Avg. Time NRFI Engines Spend at the NRFI Staging Area (days)
Baseline	5	5	1	69%	33%	67%	4%	100%	38	69	84	109	84
3	5	6	1	73%	33%	68%	4%	100%	35	71	79	109	79
	5	7	1	72%	34%	69%	4%	100%	34	73	78	104	78
	5	8	1	72%	35%	70%	4%	100%	34	71	73	102	74
	5	9	1	75%	36%	72%	4%	100%	32	71	71	103	72
	5	10	1	75%	36%	73%	5%	100%	34	67	71	101	72
	5	11	1	75%	36%	72%	5%	100%	34	69	68	97	69
	5	12	1	76%	37%	74%	4%	100%	31	71	65	98	66
	5	13	1	80%	37%	75%	5%	100%	30	69	62	94	64
	5	14	1	80%	38%	76%	4%	100%	29	68	61	92	63
	5	15	1	78%	38%	77%	4%	100%	27	70	59	94	61
Baseline	5	5	1	69%	33%	67%	4%	100%	38	69	84	109	84
4	6	6	4	89%	39%	55%	4%	100%	53	35	95	74	76
	7	7	4	90%	40%	56%	5%	100%	52	32	93	70	73
	8	8	4	92%	41%	58%	5%	100%	50	32	90	69	71
	9	9	4	91%	41%	58%	5%	100%	50	30	88	67	69
	10	10	4	90%	41%	58%	5%	100%	50	31	86	64	67
	11	11	4	91%	41%	59%	5%	100%	47	29	86	67	68
	12	12	4	92%	44%	62%	5%	100%	48	26	84	60	63
	13	13	4	92%	42%	59%	5%	100%	47	26	84	60	63
	14	14	4	91%	42%	59%	5%	100%	44	30	80	61	62
	15	15	4	92%	43%	61%	5%	100%	43	27	78	59	60
	20	20	4	91%	44%	61%	5%	100%	41	21	73	49	52

Table 6. Embellishments Three and Four Process Analyzer Results.



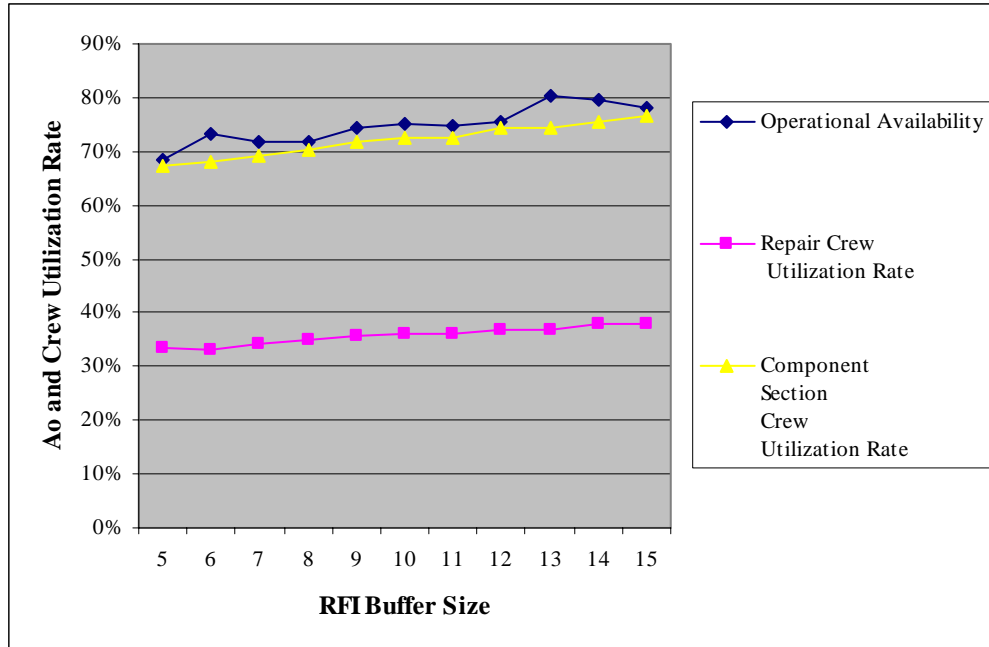

Figure 35. Embellishment 3 RFI Buffer vs. Ao/Crew Utilization Rates.

#### 4. Embellishment 4 Analysis (Buffer Size and Four QF Stations)

Table 6 also shows the results for Embellishment 4. Figure 36 illustrates that increasing the Quick Fix station to four, while increasing the buffer size, yields a significant increase in Ao. However, Ao rate peaks at a point when the buffer size is eight.

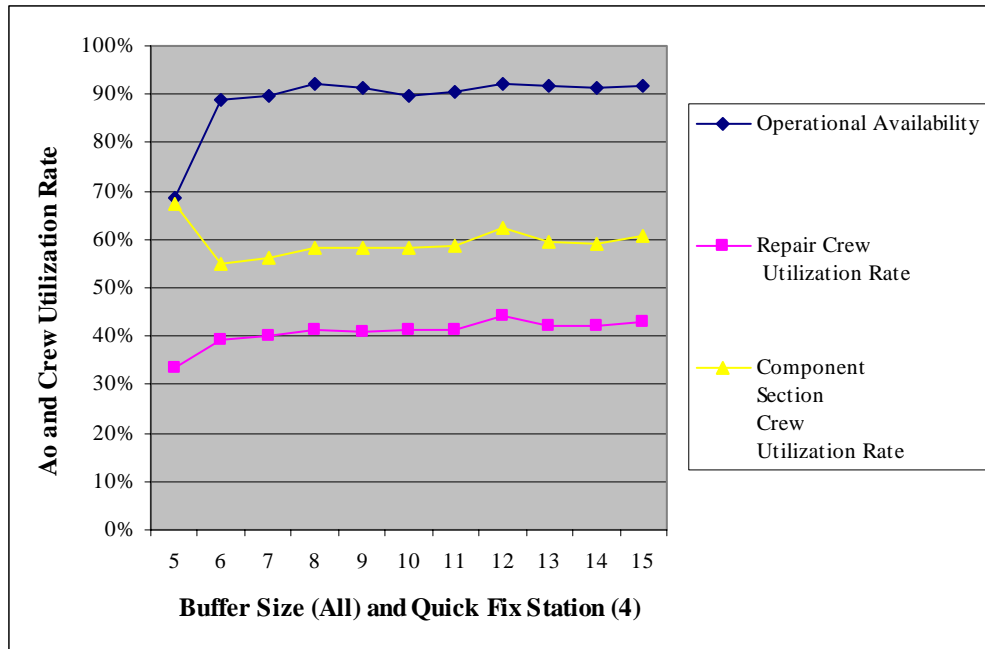

Figure 36. Embellishment 4 Buffer Size/Quick Fix Station vs. Ao/Crew Utilization Rates.

## 5. Embellishment 5 Analysis (RFI Buffer and Four QF Stations)

Table 7 shows the results for Embellishment 5. Figure 37 illustrates that increasing the Quick Fix station to four, while increasing the RFI buffer, produces the same result in Embellishment 4. The values shown in Table 7 suggests that improving the AIRSpeed engine repair process with four Quick Fix stations and nine RFI buffers will produce the highest Ao under the given conditions.

Embellishments	Supermarket Buffer Size	RFI Buffer Size	Quick Fix Repair Station	Ao	Repair Crew Util. Rate	Comp. Section Crew Util. Rate	Test Cell Util. Rate	Quick Fix Repair Station Util. Rate	Avg. Qty. of MEI Awaiting Induction	Avg. Qty. of Quick Fix Awaiting Induction	Avg. MEI Residence Time (days)	Avg. Quick Fix Residence Time (days)	Avg. Time NRFI Engines Spend at the NRFI Staging Area (days)
Baseline	5	5	1	69%	33%	67%	4%	100%	38	69	84	109	84
5	5	6	4	89%	38%	52%	5%	100%	55	34	96	73	76
	5	7	4	91%	40%	54%	5%	100%	56	30	94	68	72
	5	8	4	90%	40%	54%	5%	100%	56	28	92	67	70
	5	9	4	93%	40%	55%	4%	100%	52	29	90	66	69
	5	10	4	90%	41%	55%	5%	100%	56	26	88	61	66
	5	11	4	93%	39%	53%	4%	100%	53	28	89	66	69
	5	12	4	91%	41%	55%	5%	100%	52	26	86	60	64
	5	13	4	92%	41%	55%	4%	100%	52	24	85	59	63
	5	14	4	91%	42%	56%	4%	100%	51	26	83	58	61
	5	15	4	91%	41%	56%	5%	100%	50	24	80	55	59

Table 7. Embellishment Five Process Analyzer Results.

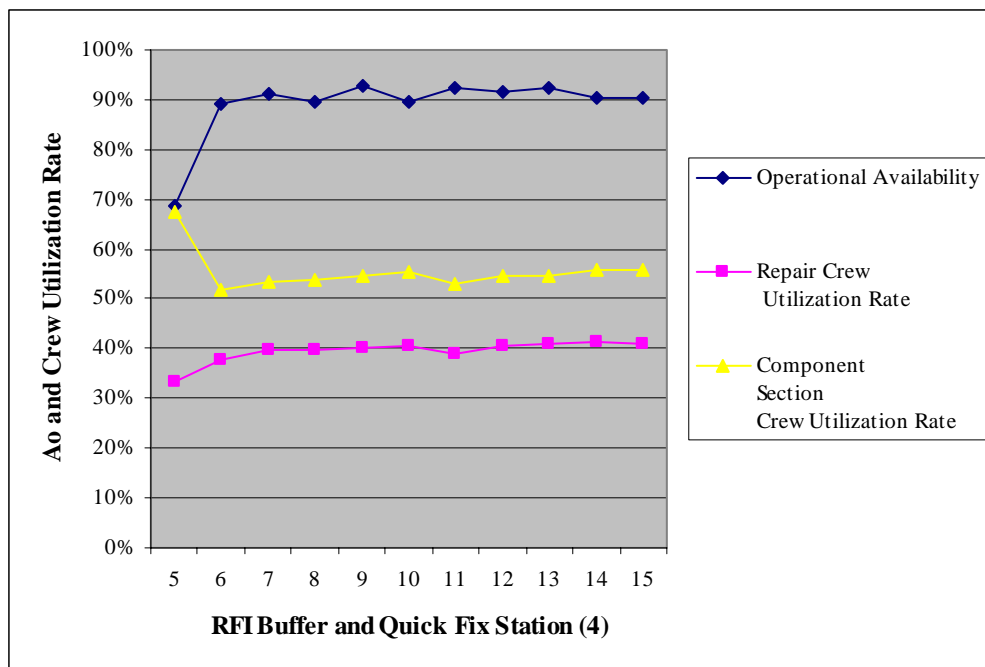

Figure 37. Embellishment 5 RFI Buffer/Quick Fix Station vs. Ao/Crew Utilization Rates.



## 6. Continuous Improvement

After comparing the results from the embellishments, the authors determined that to improve the process and bring Ao without additional cost or degrading personnel efficiency, the AIMD J52 Engine Repair Shop should increase the RFI buffer to nine and increase the number of Quick Fix stations (a work in progress) to four. AIMD should not increase the Supermarket buffer size.

### G. Maximizing Operational Availability

The previous section demonstrated how optimizing the resources in the repair facility can improve Ao. The authors also demonstrated that once the optimum values of facility resources has been achieved, Ao ceases to improve further, as it has reached its point of diminishing returns. Other factors that greatly affect Ao are engine MTBF and parts availability. These factors are beyond the controls and jurisdictions of AIMD management.

The authors ran simulation tests to confirm this claim under the following scenarios:

- Scenario 1:
  - Quick Fix parts, when placed on order, arrive on average within seven days.
  - Quick Fix station is 4.
  - RFI buffer is 9.
  - Supermarket buffer size is 5.
- Scenario 2:
  - Quick Fix parts, when placed on order, arrive on average within three days.
  - Quick Fix station is 4.
  - RFI buffer is 9.





- Supermarket buffer size is 5.

Figure 38 illustrates the effects of improving MTBF and parts availability in the J52-P408 logistics system. Ao increases with improved MTBF. In the same manner, parts availability complements MTBF by bringing Ao closer to 100%. Although both scenario results appear to be the same, the Ao curve for Scenario 2 (improved parts lead time) is steeper, hence, it is the better choice.

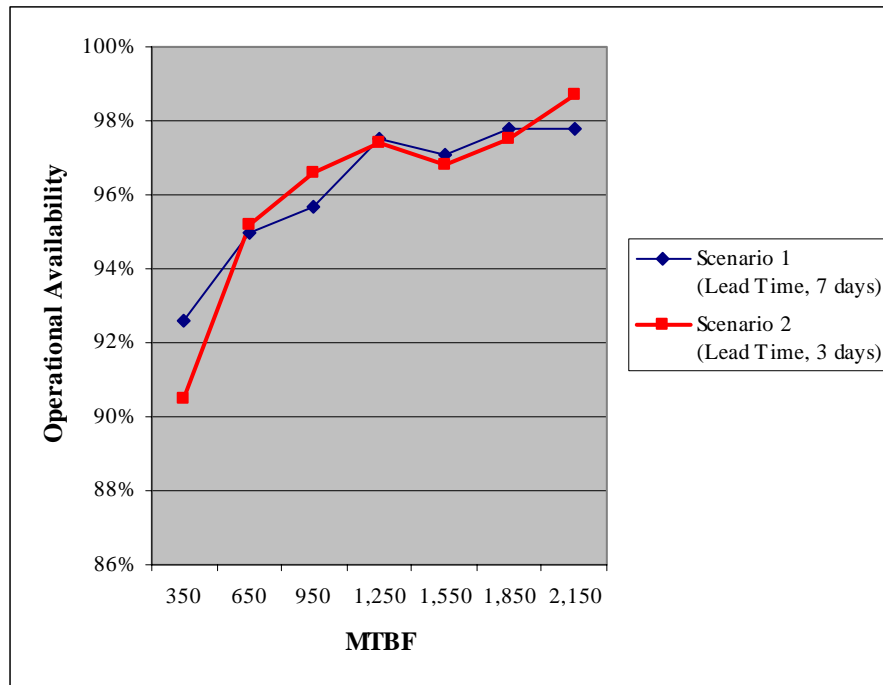

Figure 38. MTBF vs. Ao.



## VI. Conclusions and Recommendations

### A. Conclusions

Based on the analysis of the simulation model and embellishment results, the authors conclude that the AIRSpeed process at AIMD J52 Engine Repair Shop is effective. The methodologies employed by the AIRSpeed Team proved to be beneficial in expediting the engine repair process once the engine is inducted. Consequently, personnel are working more efficiently and providing more time for quality work, professional training, and family time.

The authors also conclude that the AIRSpeed process is fault-free. According to simulation results of the Pre-AIRSpeed and AIRSpeed repair processes, the authors observed a relative decrease in the Prowler fleet Ao. A temporary deviation from the current AIRSpeed process only leads to a “Bullwhip” effect in production scheduling. This forces the AIMD management to react to a seemingly fluctuating engine demand (number of bare firewalls in the Prowler fleet), not realizing that the demand driver (engine MTBF) is relatively constant. Fortunately, the process is designed to be flexible and the issue can be resolved without incurring additional cost to the Navy.

The authors presented the following conclusions:

- The new process accelerated the engine repair cycle (turnaround) time, between MEI and Quick Fix inductions, producing a faster throughput.
- The new process reduced the utilization rate of the crew, uncovering additional capacity from the crew to produce more output. The crew is performing more efficiently when asked to produce the same output. According to Table 3, the values for crew utilization rates decreased from 64% down to 33%, hence, they can be used to improve personnel morale.



- The current repair process relatively decreased operational availability; an issue that can be resolved by increasing the RFI buffer and the Quick Fix station.
- Increasing the quantity of the RFI buffer without adjusting the quantity of other resources in the production line will not produce any desired effect.

## B. Recommendations

The authors make the following recommendations for the J52 Engine Repair Shop based on our observations, analysis of the data collected, and the working processes discovered during our two site visits to Whidbey Island NAS.

### 1. Recommendation One

Increase the RFI buffer to nine and the Quick Fix station to four. Refer to Embellishment 5.

This recommendation has to be accomplished at the same time, and is not a choice between improving just one or the other. Refer to the results for Embellishments 1 and 3. Adhering to this recommendation optimizes resources and maximizes the resource output. Consequently, the crew still works more efficiently compared to the old process. The crew utilization rate for this production line setup is only 40% compared to the old process of 64%. Any additional quantity would yield no added value.

### 2. Recommendation Two

Do not increase the size of the Supermarket buffer.

Increasing the Supermarket buffer's size requires more parts, which equates to more cost and administrative burden. The desired result for this action can be accomplished by observing Recommendation 1. Refer to Embellishments 4 and 5.



### **3. Recommendation Three**

The authors recommend that AIMD establish several permanent positions to provide continuity because of the inherent high turnover rate of key positions held by officers and senior enlisted personnel. A permanently assigned position or billet as the AIRSpeed Officer and Chief would remove most of the variability in managing a program that is constantly changing. The position should be held for at least two years and allow for a one- or two-month turnover in order to address all of the ongoing AIRSpeed issues. Furthermore, the AIRSpeed Officer and Chief should be qualified “Black Belts” or achieve the qualification within the first three months of being assigned to the position. Subsequently, E-6 and below personnel assigned to work in the AIRSpeed Office should be qualified “Green Belts” or achieve their qualifications within the first three months of being assigned.

### **4. Recommendation Four**

The authors recommend that the Division Officer should have, at a minimum, the same qualification criteria as the AIRSpeed Officer. Having the Division Officer understand the concepts of AIRSpeed will allow them to keep the improved process intact.

### **5. Recommendation Five**

The authors recommend incorporating nonmonetary incentives for promoting the AIRSpeed process. One such incentive could be rewarding a division, branch, or individuals with time off for achieving specified command objectives, and another could be official recognition including letters of appreciation and achievement awards for increased advancement potential.

## **C. Criticisms on “Lean”**

There are some criticisms of how effectively the Lean process could be implemented in a military environment, which is vastly different from the corporate business world. Below are some of the authors’ thoughts on these issues:



### **1. Criticism One**

How is Green Belt/Black Belt status being applied in a hierarchical leadership structure?

The authors found that the AIRSpeed program Black Belts and Green Belts at NASWI AIMD played no significant differentiation of roles as staff positions in the military hierarchical rank structure. All recommendations for improvements were vetted through the senior leadership of the command, who in turn made the final decision on whether to implement any recommended process improvement or changes in direction for the betterment of the command. However, since AIMD is in its infancy in implementing the AIRSpeed program and not all of its personnel are qualified as Black or Green belts, this may become an issue for them down the road.

### **2. Criticism Two**

The goal of Lean is to achieve “Zero Waste,” therefore, how can the military achieve Lean in such a vast area of uncertainty and variability?

Under the environment that DoD operates in, the goal of achieving zero waste is impractical. Thus, the concept of Lean has to be slightly modified to adjust for the uncertainty and variability of Naval aviation maintenance demands. Therefore, the future Fleet Readiness Centers (FRCs) need to have the correct buffer size to address unforeseeable failures that could cause peak demands. Having the proper buffer level would provide the FRC with the ability to meet the initial demand in order to reduce backlog and also minimize the Bull-Whip effect.

### **3. Criticism Three**

What are the incentives for technicians to seek continuous improvements (Kaizen)?

It is unreasonable to expect to utilize the corporate world's incentives for promoting the Lean process in the military. The military does not have the same incentive packages as the business world, which makes it much more difficult for



military personnel to seek continuous improvements. However, military personnel do it for the sense of pride in accomplishing their duties and knowing that what they are doing will be beneficial to our war fighters on the front line. Thus, military organizations are focusing on non-monetary awards to provide incentives to their personnel.

#### D. Summary

NASWI AIMD achieved its original objective of reducing the J52 engine repair cycle time through the application of methodologies sanctioned by the AIRSpeed program. Thus, the implemented AIRSpeed repair process met the expectation of a cost-wise performance by increasing the efficiency and production capacity of the crew, and by eliminating excessive spare parts on the production floor. Additionally, an optimized AIRSpeed process offers the opportunity for increased J52 engine availability for the Prowler fleet, following minor buffer size adjustments, and produces a higher Prowler operational availability rate.

The DoN's vision to achieve cost-wise performance by emulating proven corporate business concepts does have drawbacks:

- The incentives awarded to corporate employees are not authorized in the military.
- The inherent military attitude of resistance to change, in conjunction with individual leadership management styles, does not make it easy to implement new programs.
- Furthermore, the success of implementing AIRSpeed requires full buy-ins throughout the enterprise.
- It also needs a motivated leader with positional continuity, proper training, and the qualifications to effectively establish the initial foundation.

The DoN needs to further investigate the return on investment (ROI) AIRSpeed is providing. The concept is well established in the corporate world, but not in the military. Does the ROI reaped from implementing AIRSpeed exceed the



unmeasured inventory holding cost triggered by this program? The DoN needs to initiate a cost benefit analysis comparing the cost savings and true inventory holding cost generated from the implementation of AIRSpeed. Therefore, the lack of RFI engines in the supply system might lead an individual to wonder if the DoN has the right objectives in mind.

#### E. Future of Naval Aviation Repair Facilities

The Navy is moving from three levels of maintenance to two levels of maintenance with the establishment of FRCs. By employing a Naval Aviation Enterprise Approach and AIRSpeed culture, the Navy is combining AIMDs and NADEPs to form one level of maintenance. There will be six new FRCs and each one will be responsible for maintenance on a specific T/M/S aircraft. These new FRCs are illustrated in Figure 39. O-level maintenance will continue to operate in its current manner. The FRCs will not create an additional management layer because the Commodores will retain their leadership function over the FRCs. These optimized FRCs will be referred to as Centers of Excellence.

The purpose of consolidating the AIMDs and NADEPs is to shift the maintenance concept<sup>105</sup> to two levels (On Flight Line and Off Flight Line), move capability to the Fleet, improve the value-streaming process, reduce total system cycle time, reduce work content by eliminating task duplication, reduce material requirement, and reduce work in progress (WIP) in the system. The merger will reduce overall administrative processes and allow NAVAIR to recalculate the required spare level or buffer for each region to accurately meet the Fleet's demand.

---

<sup>105</sup> Naval Air Systems Command, "Transforming Naval Aviation Maintenance for the 21<sup>st</sup> Century," PowerPoint Presentation, 2005, slide 12.



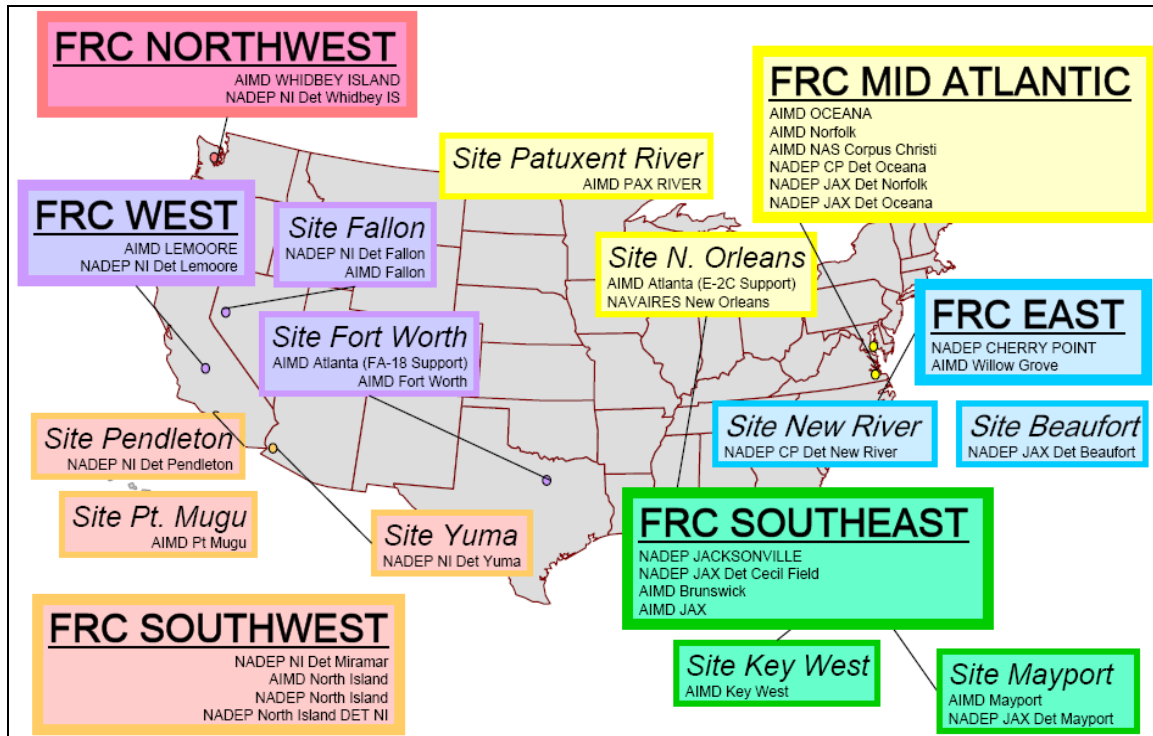

Figure 39. Fleet Readiness Centers' Regions and Repair Sites.<sup>106</sup>

<sup>106</sup> Naval Air Systems Command, "Transforming Naval Aviation Maintenance for the 21<sup>st</sup> Century," PowerPoint Presentation, 2005, slide 13.





THIS PAGE INTENTIONALLY LEFT BLANK



## List of References

Agrawal, M.K. and Pak, M.H., "Getting Smart About Supply Chain Management," *The McKinsey Quarterly*, New York, 2001.

Almyta Systems, "History of Lean Manufacturing," retrieved on August 21, 2006 from [http://systems.almyta.com/articles/Inventory\\_Management\\_History\\_7.asp](http://systems.almyta.com/articles/Inventory_Management_History_7.asp), 2006.

Apte, U. and Kang, K., "Lean Six-Sigma for Reduced Cycle Costs and Improved Readiness," Technical Report NPS-LM-06-033, Naval Postgraduate School, Monterey, CA, 2006.

Ball, J., "Chrysler Averts a Parts Crisis," *The Wall Street Journal*, (Eastern ed.), New York, NY, September 24, 2001.

Benchmark Publications, Inc., Naval Air Station Whidbey Island Website, retrieved in May 2006 from <http://www.militarynewcomers.com/WHID/Resources/Tenantcommands.html>, 2004.

Department of the Air Force, *Oil Analysis Program*, Air Force Instruction 21-124, retrieved on September 12, 2006 from <http://www.e-publishing.af.mil/pubfiles/af/21/afi21-124/afi21-124.pdf#search=%22fda%20oil%20analysis%22>, April 2003.

Department of the Navy, COMVAQWINGPAC, Power Plants Office, "J52 MEFHBR," PowerPoint Presentation, 2006.

———, COMVAQWINGPAC, Power Plants Office, "Monthly Production Report," Excel Spreadsheet, 2006.

———, Naval Air Systems Command, "Transforming Naval Aviation Maintenance for the 21<sup>st</sup> Century," PowerPoint Presentation, 2005.

———, Office of Information, "CNO Guidance for 2003," retrieved on August 13, 2006 from <http://www.chinfo.navy.mil/navpalib/cno/clark-guidance2003.html>

———, OPNAVINST 4790.2J, *Naval Aviation Maintenance Program*, Vol. I, Chapter 18, February 1, 2005.

———, Technical Manual, *Intermediate Maintenance Aircraft Engines Navy Models J52-P-408 and P-408A/B*, NAVAIR 02B-10DAD-6-1V1, WP 001 01, January 13, 1993.



- Dolcemascolo, D. "Seven Wastes of the Extended Value Stream," EMS Consulting Group, retrieved on July 10, 2006 from <http://www.emsstrategies.com/dd120104article1.html>, December 2004.
- , "Value Stream Mapping," EMS Consulting Group, retrieved on August 21, 2006 from <http://www.emsstrategies.com/dd020105article.html>, February 1, 2005.
- , "Lean Production Control: Pull Systems," retrieved on August 21, 2006 from <http://www.emsstrategies.com/dd100105article.html>, October 1, 2005.
- EMS Consulting Group, Inc., "Lean and the Extended Value Stream," retrieved on August 21, 2006 from <http://www.lean-supply-chain.com>, 2006.
- Feld, W.M., *Lean Manufacturing: Tools, Techniques, and How to Use Them*, Boca Raton, FL: St. Lucie Press, 2001.
- General Accounting Office, "Major Management Challenges and Program Risks: Department of Defense," GAO-01-244, January 2001.
- , "Defense Inventory: Navy Logistics Strategy and Initiatives Need to Address Spare Parts Shortages," Report to the Chairman, Subcommittee on Defense, of the House Committee on Appropriations, GAO-03-708, June 2003.
- , "Military Aircraft: Cannibalization Adversely Affects Personnel and Maintenance," Testimony before the Subcommittee on National Security, Veterans Affairs, and International Relations, of the House Committee on Government Reform, GAO-01-693T, May 2001.
- Gupta, P., *Six Sigma Business Scorecard: Ensuring Performance for Profit*, New York, NY: McGraw-Hill, 2004.
- Haley, B., "EA-6B Thrives with NAVRIIP/Enterprise AIRSpeed," retrieved on May 13, 2006 from <http://www.cnaf.navy.mil/airspeed/main.asp?ItemID=413>, November 2004.
- Hickey, P., Da Cruz, M., and Seaver, S., "Benchmarking Lean Manufacturing and the Theory of Constraints Implementations," Bearing Point, Inc., August 5, 2003.
- Kang, K., "Logistics Engineering," Lecture Notes, Graduate School of Business and Public Policy, Naval Postgraduate School, Monterey, CA, 2006.
- Kelton W.D., Sadowski R.P., and Sturrock, D.T., *Simulation with Arena*, McGraw-Hill Higher Education: Singapore, 3rd ed., 2003.



- Lee, H.L., "The Triple-A Supply Chain," *Harvard Business Review*, Vol. 82, Iss. 10, Boston, October 2004.
- Mawby, W.D., *Decision Process Quality Management*, Milwaukee, WI: ASQ Quality Press, 2004.
- McBride, D., "Lean Culture," retrieved on August 21, 2006 from <http://www.emsstrategies.com/dm070104article1.html>, July 2004.
- , "The 7 Manufacturing Wastes," retrieved on July 10, 2006 from <http://www.emsstrategies.com/dm090203article2.html>, August 2003.
- McMullen, T.B., *Introduction to the Theory of Constraints (TOC) Management System*, Boca Raton: FL: St. Lucie Press, 1998.
- McShane, S.L. and Young Von Glinow, M.A., *Organizational Behavior: Emerging Realities for the Workplace Revolution*, Boston, MA: McGraw-Hill Irwin, 3rd ed., 2005.
- Minahan, T., "JIT: How Buyers Changed It," *Purchasing*, Vol. 121, Iss. 3, Boston, September 5, 1996.
- Narayanan, V.G. and Raman, A., "Aligning Incentives in Supply Chains," *Harvard Business Review*, Vol. 82, Iss. 11, Boston, November 2004.
- NASWI AIMD AIRSpeed Office, "400 Before and After," PowerPoint Presentation, 2006.
- , "J52 Engine Processing," PowerPoint Presentation, 2005.
- , "J52 Process Flow Block Diagram," PowerPoint Presentation, 2005.
- , "Work Center 41A AIRSpeed Report," 2005.
- NASWI AIMD Work Center 41A, retrieved on August 24, 2006 from the NALCOMIS Database.
- Nieto, M., "Enterprise AIRSpeed," *The Navy Supply Corps Newsletter*, Vol. 68, Iss. 5, September/October 2005.
- Pike, J.E., "J52 Engines," retrieved on July 13, 2006 from <http://www.globalsecurity.org/military/systems/aircraft/systems/j52.htm>, March 2006.
- PRNewswire, "U.S. Navy Awards a Major Contract to a Connecticut Small Business," retrieved on July 19, 2006 from <http://www.prnewswire.com/cgi->



[bin/stories.pl?ACCT=104&STORY=/www/story/01-13-2006/0004248807&EDATE=](http://bin/stories.pl?ACCT=104&STORY=/www/story/01-13-2006/0004248807&EDATE=), January 2006.

Shaw, K.A., "Sunflower Seed at Syracuse," *The Education Record*, Vol. 74, Iss. 2, Washington, D.C., Spring 1993.



## Initial Distribution List

1. Defense Technical Information Center  
Ft. Belvoir, Virginia
2. Dudley Knox Library  
Naval Postgraduate School  
Monterey, California
3. Commanding Officer  
Fleet Readiness Center Northwest  
Oak Harbor, Washington
4. Professor Keebom Kang  
Naval Postgraduate School  
Monterey, California
5. Professor Uday Apte  
Naval Postgraduate School  
Monterey, California
6. Professor Ken Doerr  
Naval Postgraduate School  
Monterey, California
7. LCDR Eric Jafar  
Chesapeake, Virginia
8. LCDR(sel) Terence Noel C. Mejos  
Spring Valley, California
9. LT Chieh Yang  
Norfolk, Virginia

Copies of the Acquisition Sponsored Research Reports may be printed from our website [www.acquisitionresearch.org](http://www.acquisitionresearch.org)



THIS PAGE INTENTIONALLY LEFT BLANK





# 2003 - 2006 Sponsored Acquisition Research Topics

## **Acquisition Management**

- Software Requirements for OA
- Managing Services Supply Chain
- Acquiring Combat Capability via Public-Private Partnerships (PPPs)
- Knowledge Value Added (KVA) + Real Options (RO) Applied to Shipyard Planning Processes
- Portfolio Optimization via KVA + RO
- MOSA Contracting Implications
- Strategy for Defense Acquisition Research
- Spiral Development
- BCA: Contractor vs. Organic Growth

## **Contract Management**

- USAF IT Commodity Council
- Contractors in 21st Century Combat Zone
- Joint Contingency Contracting
- Navy Contract Writing Guide
- Commodity Sourcing Strategies
- Past Performance in Source Selection
- USMC Contingency Contracting
- Transforming DoD Contract Closeout
- Model for Optimizing Contingency Contracting Planning and Execution

## **Financial Management**

- PPPs and Government Financing
- Energy Saving Contracts/DoD Mobile Assets
- Capital Budgeting for DoD
- Financing DoD Budget via PPPs
- ROI of Information Warfare Systems



- Acquisitions via leasing: MPS case
- Special Termination Liability in MDAPs

## **Logistics Management**

- R-TOC Aegis Microwave Power Tubes
- Privatization-NOSL/NAWCI
- Army LOG MOD
- PBL (4)
- Contractors Supporting Military Operations
- RFID (4)
- Strategic Sourcing
- ASDS Product Support Analysis
- Analysis of LAV Depot Maintenance
- Diffusion/Variability on Vendor Performance Evaluation
- Optimizing CIWS Life Cycle Support (LCS)

## **Program Management**

- Building Collaborative Capacity
- Knowledge, Responsibilities and Decision Rights in MDAPs
- KVA Applied to Aegis and SSDS
- Business Process Reengineering (BPR) for LCS Mission Module Acquisition
- Terminating Your Own Program
- Collaborative IT Tools Leveraging Competence

A complete listing and electronic copies of published research within the Acquisition Research Program are available on our website: [www.acquisitionresearch.org](http://www.acquisitionresearch.org)





ACQUISITION RESEARCH PROGRAM  
GRADUATE SCHOOL OF BUSINESS & PUBLIC POLICY  
NAVAL POSTGRADUATE SCHOOL  
555 DYER ROAD, INGERSOLL HALL  
MONTEREY, CALIFORNIA 93943

[www.acquisitionresearch.org](http://www.acquisitionresearch.org)