



ACQUISITION RESEARCH PROGRAM SPONSORED REPORT SERIES

The Logistics Burden in Fully Burdened Cost Estimates

1 October 2013

**Dr. Eva Regnier, Associate Professor, and
Dr. Jay Simon, Assistant Professor**
Defense Resources Management Institute

**Dr. Aruna Apte, Assistant Professor, and
Dr. John Khawam, Assistant Professor**
Graduate School of Business & Public Policy

Dr. Daniel Nussbaum, Professor
Operations Research Department

Naval Postgraduate School

Approved for public release; distribution is unlimited.

Prepared for the Naval Postgraduate School, Monterey, CA 93943.



The research presented in this report was supported by the Acquisition Research Program of the Graduate School of Business & Public Policy at the Naval Postgraduate School.

To request defense acquisition research, to become a research sponsor, or to print additional copies of reports, please contact any of the staff listed on the Acquisition Research Program website (www.acquisitionresearch.net).



ACQUISITION RESEARCH PROGRAM
GRADUATE SCHOOL OF BUSINESS & PUBLIC POLICY
NAVAL POSTGRADUATE SCHOOL

Abstract

Military forces often operate in austere environments, where resources such as fuel and water are not available locally. Certain classes of supply such as ammunition require special—and especially costly—transportation and handling, and often must be transported thousands of miles into theater using organic assets. Moreover, logistics assets have come under threat in recent conflicts and are expected to come under wider global threat, even at sea. Together, these issues mean that the DoD should develop forces and acquire assets to support efficient organic supply networks and should place a higher value on resource efficiency in its warfighting capabilities than it has in the recent past.

This report describes our work modeling the impact of self-sustainment for logistics activities and associated force protection on the fully burdened cost of supply to the warfighter. The purpose is to support better-informed acquisition decisions as well as operational and strategic decisions for the DoN and DoD's future forces.

Keywords: Fully Burdened Cost, Logistics Model, Supply Networks, Input-Output Analysis, Force Protection



THIS PAGE INTENTIONALLY LEFT BLANK



About the Authors

Dr. Eva Regnier—Dr. Regnier is an associate professor of decision science at the Defense Resources Management Institute (DRMI). Her research is in decision making under uncertainty, with a focus on characterizing environmental uncertainty to support both optimization and judgmental decision making. She has studied the value of weather forecasts in making evacuation and other decisions, and has worked on energy and natural resources decisions for over 10 years. Her recent work on energy issues in the Department of Defense includes developing methods to estimate the system-wide impacts of energy use in forward positions and methods to estimate the value of technology demonstration projects in informing and improving future use of developing technologies. She holds a PhD in industrial engineering and an MS in operations research from the Georgia Institute of Technology and a BS in environmental engineering science from the Massachusetts Institute of Technology.

Dr. Eva Regnier
Defense Resources Management Institute
Naval Postgraduate School
Monterey, CA 93943-5000
Tel: (831) 656-2912
Fax: (831) 656-3407
E-mail: eregnier@nps.edu

Dr. Jay Simon—Dr. Simon is an assistant professor of decision science at the Defense Resources Management Institute (DRMI) at NPS. Dr. Simon's main research focus is multiattribute preference modeling. His current and recent work includes a prostate cancer decision model, preference models for health decisions, preferences over geographic outcomes, altruistic utility modeling, and time discounting anomalies. He is a member of the Institute for Operations Research and the Management Sciences (INFORMS) and the Decision Analysis Society of INFORMS. Dr. Simon joined the DRMI faculty in August 2009.

Dr. Jay Simon
Defense Resources Management Institute
Naval Postgraduate School
Monterey, CA 93943-5000
Tel: (831) 656-2457
Fax: (831) 656-3407
E-mail: jrsimon@nps.edu

Dr. Aruna Apte—Dr. Apte is an associate professor in the Department of Operations and Logistics Management at the Naval Postgraduate School. Professor Apte has successfully completed various research projects involving the application



of mathematical models and optimization techniques that have led to over 20 research articles and one patent. Her research interests are in developing mathematical models for complex, real-world operational problems using optimization tools. She values that her research be applicable. Currently, her research is focused in humanitarian and military logistics. She has several publications in journals such as *Interfaces*, *Naval Research Logistics*, and *Production and Operations Management*. She has published a monograph on humanitarian logistics.

Dr. Aruna Apte
Graduate School of Business & Public Policy
Naval Postgraduate School
Monterey, CA 93943-5000
Tel: (831) 656-7583
Fax: (831) 656-3407
E-mail: auapte@nps.edu

Dr. John Khawam—Dr. Khawam is an assistant professor at the Naval Postgraduate School GSBPP and received his PhD from the Department of Management Science & Engineering at Stanford University in 2009. His thesis focuses on warranty inventory management in the presence of a reverse supply chain. He spent 2009–2010 as a postdoc at WHU, Otto Beisheim School of Management. He received his master’s degree in 2001 and BS in 2000 from Cornell University’s OR&IE Department. He worked at Lord & Taylor as an internal consultant, where he received Six Sigma training. He has also worked at Gap Inc., Eaton Corp., Allied Signal, and End-2-End Analytics.

Dr. John Khawam
Graduate School of Business & Public Policy
Naval Postgraduate School
Monterey, CA 93943-5000
Tel: (831) 656-2470
Fax: (831) 656-7633
E-mail: jhkhawam@nps.edu

Dr. Daniel Nussbaum—Dr. Nussbaum is the chair of the Energy Academic Group at the Naval Postgraduate School. His expertise is in cost/benefit analyses, life cycle cost estimating and modeling, budget preparation and justification, performance measurement and earned value management (EVM), activity-based costing (ABC) and total cost of ownership (TCO) analyses. From December 1999 through June 2004 he was a principal with Booz Allen Hamilton, providing estimating and analysis services to senior levels of the U.S. federal government. He has been the chief advisor to the Secretary of Navy on all aspects of cost estimating and analysis throughout the Navy, and has held other management and analysis positions with



the U.S. Army and Navy, in the United States and in Europe. In a prior life, he was a tenured university faculty member.

Dr. Daniel Nussbaum
Operations Research Department
Naval Postgraduate School
Monterey, CA 93943-5000
Tel: (831) 656-2387
Fax: (831) 656-2595
E-mail: danussba@nps.edu



THIS PAGE INTENTIONALLY LEFT BLANK





ACQUISITION RESEARCH PROGRAM SPONSORED REPORT SERIES

The Logistics Burden in Fully Burdened Cost Estimates

1 October 2013

**Dr. Eva Regnier, Associate Professor, and
Dr. Jay Simon, Assistant Professor**
Defense Resources Management Institute

**Dr. Aruna Apte, Assistant Professor, and
Dr. John Khawam, Assistant Professor**
Graduate School of Business & Public Policy

Dr. Daniel Nussbaum, Professor
Operations Research Department

Naval Postgraduate School

Disclaimer: The views represented in this report are those of the author and do not reflect the official policy position of the Navy, the Department of Defense, or the federal government.



THIS PAGE INTENTIONALLY LEFT BLANK



Table of Contents

Executive Summary	xv
Department of Navy Energy Requirements and Logistics	1
Modeling Approach	3
Fully Burdened Cost Estimation Approaches	3
A Brief Review of Logistics Models	4
Economic Input–Output Analysis.....	4
Types of Decisions Supported.....	5
Model	5
Self-Sustainment.....	5
A Transportation Chain	8
Multiple Resources.....	8
A Logistics Network.....	11
Burden of Force Protection	15
Threatened Sea Logistics	16
Model	17
Network	17
Consumption Rates	19
Scenario	20
Input–Output Model	21
Operating and Support Costs.....	22
Combining Air, Land, and Sea	22
Humanitarian and Disaster Relief	23
Deployment Phase.....	24
Conclusions and Recommendations.....	24
References	27



THIS PAGE INTENTIONALLY LEFT BLANK



List of Figures

Figure 1.	The Relationship Between Distance and the Fuel Multiplier for a Two-Node Supply Chain Consuming Only Fuel.....	7
Figure 2.	A Transportation Chain With n Nodes.....	8
Figure 3.	Schematic of a Portion of USMC Organic Logistics Network in Afghan's Helmand Province in 2009, Developed by Sean R. Dubbs (2011).....	12
Figure 4.	Schematic of a Hypothetical Logistics Network.....	13
Figure 5.	Global Network Model From CLFP <i>Note</i> . Nodes are shown as circles, and arcs are shown as lines connecting them.	18
Figure 6.	User Input Dialog Box in Naval Threat-Based Fully Burdened Cost Model	19
Figure 7.	Examples of Ship Planning Factors From the Combined Logistics Force Planner.....	20



THIS PAGE INTENTIONALLY LEFT BLANK



List of Tables

Table 1. Input–Output Formulation of the Logistics Network Shown in Figure 4 13



THIS PAGE INTENTIONALLY LEFT BLANK



Executive Summary

The work described in this report follows FY2011 and FY2012 efforts funded by the Naval Postgraduate School (NPS) Acquisition Research Program (ARP) motivated by the challenge of estimating the fully burdened cost (FBC) of fuel (FBCF) and energy (FBCE) more broadly. We expanded this to include the costs of other supply, such as water, and use the term FBC of supply (FBCS). The prior years' work is reported in Regnier and Nussbaum (2011) and Regnier, Simon, and Nussbaum (2013).

Our work has introduced new logistics models tailored to support cost estimation, rather than operational planning, and has identified mechanisms for bias—in particular, underestimation—of the burden associated with supplying the warfighter in austere conditions and under threat. We introduced the terms *self-sustaining supply network* and *fuel multiplier* and the concept of cross-resource multipliers. We have shown that force protection has an important interaction with the multiplier effect, and therefore self-sustainment is especially important when threatened logistics are anticipated.

As part of this effort, we have communicated with one contractor team and one Army team that have developed FBC estimation tools. In each case, the versions of the tools at that time neglected the multiplier effect. In the case of the contractor, they were missing the fuel multiplier effect. In the case of the Army team, they had added the fuel multiplier effect, and had plans to add cross-multipliers for fuel and water. The basic approaches underlying these tools, however, made capturing all cross-resources multipliers challenging.

In addition to NPS technical reports and the ARP proceedings, we have advised three theses: Hills (2011), Dubbs (2011), and Hathorn (2013), and published one peer-reviewed article (Regnier, Simon, Nussbaum, & Whitney, in press), with another under review (Apte, Khawam, Regnier, & Simon, 2013) and a third in preparation.

In FY2013, we completed a model of naval logistics in support of underway replenishment with threatened transportation routes, as reported below; this model is very similar to that reported in Hathorn (2013). In addition, we further developed the model of multiple resource types and cross-resource multiplier effects.



THIS PAGE INTENTIONALLY LEFT BLANK



The Logistics Burden in Fully Burdened Cost Estimates

Department of Navy Energy Requirements and Logistics

The *Fiscal Year 2011 Operational Energy Report* (Assistant Secretary of Defense for Operational Energy Plans and Programs [ASD(OEPP)], 2013) indicates that the Department of Defense (DoD) consumes an enormous quantity of fuel—114 million barrels for operational uses, at a cost of almost \$17 billion. Moreover, it spends considerable additional resources moving that fuel. The ASD(OEPP; 2013) estimates that fuel and water account for 70–80% of ground logistics. That percentage is well over 90% for naval logistics (Hathorn, 2013). Nevertheless, newer platforms and weapons systems are less fuel efficient than those they are replacing. The 2009 Duncan Hunter National Defense Authorization Act (NDAA, 2008) instructed the DoD to estimate the cost associated with the logistics of delivering fuel to the warfighter, and to use this cost in evaluating weapons systems and platforms, so that a more accurate value would be placed on fuel requirements when tradeoffs are made in the acquisition process (§ 332).

The absolute dependence of military capability on logistics is an ancient maxim dating back at least as far as Sun Tzu, and continuing into the United States' most recent conflicts in Iraq and Afghanistan. Almost as famously, warfighters tend to pay too little attention to their logistics, simply counting on the needed supplies to be provided. This neglect occurs operationally—as when Rommel famously and ambitiously got ahead of his logistics in North Africa in WWII—and arguably, when U.S. forces in Operation Desert Storm moved so fast across Iraq that supply lines could not keep up with them.

The same neglect occurs in longer range decisions such as force planning and especially in the acquisition process; the modern DoD is no exception. Quoting the Defense Science Board (DSB; 2001),

Although significant warfighting, logistics and cost benefits occur when weapons systems are made more fuel-efficient, these benefits are not valued or emphasized in the DoD requirements and acquisition processes. ... [which] distorts platform design choices. (p. ES-2)

And in 2008, the DSB found that the DoD had not implemented “the main Task Force recommendation in 2001 [to] re-engineer its business processes to make energy a factor in the key Departmental decisions that establish requirements, shape acquisition programs and set funding priorities” (p. 3).



Following the 2008 DSB report and the 2009 NDAA, which directed the DoD to implement fully burdened cost of fuel (FBCF), the DoD developed detailed guidance on the estimation of FBCF, which was expanded to include power, and changed the name to fully burdened cost of energy (FBCE; DoD, 2013). The ASD(OEPP) issued specific guidance promulgated by the DoD (2013) in Section 3.1.6 of the *Defense Acquisition Guidebook (DAG)* on how to estimate the FBCE for a system.

One dimension has been overlooked, however, that is especially important when the resources necessary to sustain the logistics activities themselves are not locally available. As van Creveld (2004) stated, “By and large, the story of logistics is concerned with the gradual emancipation of armies from the need to depend on local supplies” (p. 182). When supplies required by logistics activities—in particular fuel, but including spare parts, food, water, and other sustainment for logistics personnel, and in some cases, supplies for the protection of the logistics assets—are not locally available, they must be supplied by the supply network. This creates a feedback effect and geometrically increases the amount of resources required to sustain warfighting activities.

We have termed this phenomenon the *multiplier effect* (Regnier, Simon Nussbaum, & Whitney, in press), but we are not the first to describe it qualitatively. For instance, referring to operations in the South Pacific in August 1942, Carter, Kimball, and Spruance (1953) stated, “Since the lack of proper logistic support for Fletcher was the cause of Turner's inability to land much desirable equipment and supplies, **we see logistics depending upon logistics**” (emphasis added, p. 30). The resupply effort was delayed by insufficient supply, precisely the feedback loop that drives the multiplier effect.

In Rommel's (1982) memoirs of his campaign in North Africa, his often-cited statement on the role of logistics is that

the battle is fought and decided by the quartermasters before the shooting begins. The bravest men can do nothing without guns, the guns nothing without ammunition, and neither guns nor ammunition are of much use in mobile warfare unless there are vehicles **with sufficient petrol** to haul them around. (emphasis added; p. 328)

The highlight is important because it illustrates the multiplier effect: The transport vehicles themselves require fuel. This is the multiplier effect in action.

Van Creveld (2004) described in fascinating detail Rommel's logistics challenges, discounting the importance of the air–sea combat in the Mediterranean, arguing instead that the determining factor was “the impossible length of his line of communications inside Africa ... it would be reasonable to guess that thirty to fifty percent of all the fuel landed in North Africa was wasted between Tripoli and the



front” (p. 190). This implies an efficiency of 50% to 70% once the fuel had landed in Africa, and a much lower efficiency of the entire supply network from inside Italy to the front.

When supply lines are contested, the cost in dollars, assets, and lives to deliver fuel to the warfighter goes up dramatically. The Army Environmental Policy Institute (AEPI) estimated that the United States incurred one casualty for every 24 fuel resupply convoys in Afghanistan (Eady, Siegel, Bell, & Dicke, 2009). Citing the Center for Army Lessons Learned, Eady et al. (2009) estimated that historically, about 10%–12% of Army casualties may be attributed to resupply. Force protection, which was a critical element of all supply in the global battle of WWII, adds another layer of logistics and further degrades the efficiency of the logistics network. In the air–sea battle in the Mediterranean in the winter of 1941–1942, the Axis side had “100,000 tons of warships being used to protect 20,000 tons of merchant shipping, and the cost in fuel became prohibitive” (van Creveld, 2004, p. 191). Strategic guidance and war games indicate that threatened logistics networks should be anticipated in the future (Schwartz, Blakely, & O’Rourke, 2012).

Our work indicates that the true logistics burden—accounting for the multiplier effect—can easily be 20% to 50% higher than naïve estimates, even in very short supply networks in austere regions. For longer supply networks, the logistics burden may easily be two or three times higher when logistics are threatened, thus requiring substantial force protection, even if the impact of attrition is not counted.

Modeling Approach

The burden of delivering fuel is different for different end-using locations, and the appropriate allocation of costs for different transportation modes and different paths through the supply network to a given end-using location is not obvious. Furthermore, early approaches to estimating FBC systematically neglected the multiplier effect, created by resource requirements of logistics activities on the total organization-wide costs.

Fully Burdened Cost Estimation Approaches

Most FBCE approaches build a model of logistics that defines the boundaries quite narrowly. They generally build up the cost estimate from costs of individual assets used in logistics—transportation and force protection assets—and then estimate a cost associated with their usage per unit distance or time. The unit costs tend to be averages over the operating lifetime of platforms or hourly rates for personnel. For multistage networks, these models estimate the requirements per unit of supply delivered along each stage, then they add across stages. For every tool we are familiar with, the first version charged resources consumed by that network—for example, fuel, at the “commodity” rate, which for fuel is the Defense



Logistics Agency–Energy (DLA–E) rate, regardless of where in the network it was consumed. For example, if a scenario called for helicopter air support, the cost of fuel for that air support would be estimated using the DLA–E fuel price even if the helicopter would be refueling in a forward operating position. The Army FBC tool has apparently modified its tool from its first iterations, to use an FBCF for fuel used by logistics assets at forward positions. The general approach does not lend itself easily to accounting for the logistics required to sustain the logistics activities.

A Brief Review of Logistics Models

Most logistics models are used for operational planning. The Replenishment at Sea Planner (RASP) described by De Grange (2005) is a good example. In contrast with our approach, even those models that are used for longer range decisions are generally dynamic, that is, they model logistics activities with both the time and space dimension. One example is the Combined Logistics Force (CLF) Planner that has been used to explore the impacts of fleet sizing alternatives, as described by Brown and Carlyle (2008). A second is Gue's (2003) facility location and distribution model designed to support the configuration of efficient networks for military supply distribution.

Economic Input–Output Analysis

Input–output (IO) analysis is a relatively simple but powerful approach. It was first developed for analyzing national economies (Dietzenbacher & Lahr, 2004; Leontief, 1986) using industries and sub-industries as the units of analysis (components), and this is still its most common use. However, IO analysis has been extended in recent years to model more specific details about the material and economic relationships within the economy. In this work, we are particularly interested in physical IO analyses, which model materials and resource requirements, and their impacts throughout an entire system (Hoekstra & van den Bergh, 2006).

IO analysis uses a set of coefficients that represent the amount of output of a given component required per unit of output of another component. These coefficients, together with the output quantities of each component and the assumption of mass balance (the outputs of each component must satisfy the input requirements of all others) constitute a fully determined system of equations. These may be used to explore the effect of changes in any single part of the system, for example, a reduction in the fuel requirement in one component.

An IO model consists of defined components (in national accounts, the components are industries) that represent the unit of analysis, plus a matrix of coefficients (sometimes called technical coefficients). For each pair of components (i, j) , the coefficient a_{ij} is the amount of output of component i required as an input



to component j , per unit of output from component j . These coefficients, together with an output quantity x_j from each component j , satisfy a set of linear equations that enforce mass balance for each component—its output must be exactly enough to satisfy the input requirements of the other components.

Despite its simplicity, IO has been enormously influential, earning a Nobel prize for Leontief, and becoming the foundation for a huge body of research. Moreover, it has produced insights that were overlooked by earlier analyses. For example, Baumol and Wolff (1981) used IO analysis to evaluate the impact of subsidies for energy production and found that prior analyses had neglected system-wide effects and therefore underestimated the total energy requirements (and costs) of the energy production. This is analogous to our finding that thorough but naïve analyses underestimate the resources and costs associated with supply networks.

IO analysis has not been widely applied at the enterprise level. Marangoni and Fezzi (2002) are one exception; they found that their model of GlaxoSmithKline was approximately as accurate as the existing method, which is based on sales projections, at predicting total profits two years into the future. In addition, IO is less costly and more flexible than the existing method.

Types of Decisions Supported

The motivation for this work is to support cost estimates for the Department of the Navy (DoN) and DoD more broadly. Our results are especially important in evaluating investments that can affect the resource efficiency of the warfighter or of logistics activities, especially in austere environments. For example, IO estimates of FBCS could have a substantial impact on cost–benefit analyses of materiel for expeditionary missions and for humanitarian and disaster relief, as well as assets to support long supply lines in a contested environment.

In recent years, the DoN has evaluated adopting technologies such as the pre-positioned expeditionary assistance kit, which has a water purifier that makes 1,800 gallons of potable water per day from local sources, and the ground-renewable expeditionary energy system that combines solar panels, batteries, and management software to provide renewable power on the battlefield.

Model

Self-Sustainment

As in most transportation or transshipment models, we consider a set of nodes, which can be considered depots, and the arcs that connect the depots.¹

¹ In some transportation models, logistics activities that occur at a single geographic location, such as handling and storage, may be modeled as multiple co-located nodes connected by arcs. This would



Supply is transported from the origin node to the destination node along an arc connecting nodes i and $i + 1$.

In a self-sustaining network, each arc consumes resources, as, for example, logistics vehicles or vessels consume fuel and personnel consume food and water. Within an arc, it is assumed for simplicity that the logistics activities can draw from the payload costlessly, for example, that an oiler is able to refuel itself from its payload fuel. (This assumption does not qualitatively affect any of our results.) Therefore, the quantity of supply departing node i is greater than the quantity arriving at node $i + 1$. This is unusual for a network model, in which flow along a given arc is generally a single value. We therefore let x_i denote the quantity arriving at node i . For now, we are considering a logistics chain, where each node (except the source) has exactly one inbound arc, and we are assuming that each piece of the chain is operating at exactly the rate needed to meet all demands. Therefore, x_i is also equal to the amount needed at that node (per unit of time or per delivery).

To model logistics activities' consumption of resources, an arc is characterized by the resources it consumes, reflected by the arc's multiplier or a related measure of efficiency. An important insight of this model is that on a self-sustaining arc, the total amount of resources required at the origin of an arc increases geometrically with the arc's distance, even holding the amount required at the destination node equal.

For example, consider a single vehicle transporting fuel along an arc of distance d , which may be measured in units of length or time. Let this vehicle consume only fuel (no spare parts or food and water for the driver), and let r represent the rate at which the transportation vehicle consumes fuel per unit of distance (no fixed costs for loading and unloading) and w represent the vehicle's total fuel capacity, including both its payload and its internal fuel tank. Figure 1 shows the amount of fuel needed at the origin (node i per unit of fuel delivered to node $i + 1$), that is, the one unit of fuel delivered to node $i + 1$, plus the additional amount burned in transit, for any given distance d . This number is the fuel multiplier associated with transportation between the two nodes and is denoted by λ = the amount or resources required at the beginning of the arc divided by the amount delivered at the end. In this simple model, $\lambda = w/(w - 2rd)$ where the coefficient 2 reflects that the vehicle travels a round trip on each delivery. Note that the fuel multiplier, λ , is an increasing and convex function of distance, and has an asymptote at $d = w/2r$. It is impossible for the vehicles to deliver fuel a distance of $d = w/2r$ or greater.

allow some interactions between activities at a single depot to be captured in the model. We do not use this abstraction in this report.



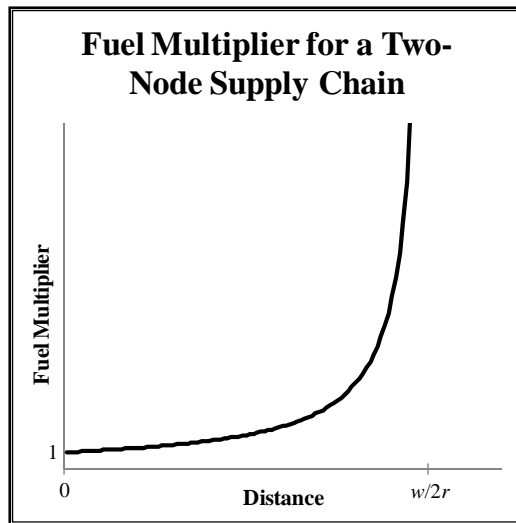

Figure 1. The Relationship Between Distance and the Fuel Multiplier for a Two-Node Supply Chain Consuming Only Fuel

In the simple model shown in Figure 1, there is only one type of supply transported and consumed, and consumption in transit is proportional to distance. In reality, resources may be consumed by logistics activities such as loading, unloading, warehousing, and maintenance at each node, and therefore their consumption would not be proportional to the distance of the arc. Including such a fixed (with respect to distance) cost f would raise the multiplier for a zero-distance arc and reduce the fuel multiplier's asymptote to $(w - f)/2r$. The fuel multiplier would still be a convex function of distance.

There are two challenges associated with estimating the cost per unit of supply delivered to the end of an arc. The first is the universal cost-estimation challenge of identifying all classes of costs affected by an activity. The challenge is acute in this case because the resources required by logistics activities are provided and accounted for by different units of the organization. For example, stores and hoteling services consumed by logistics personnel are likely not broken out from those consumed by other personnel stationed at the same place.

A second cost-estimating challenge is that self-refueling is generally unfamiliar to cost estimators. If fuel consumption by logistics assets reduces the amount that may be delivered to the end of an arc, this impact, which produces the rapidly increasing slope in **Error! Reference source not found.**, is likely to be neglected in the cost estimation.

However, if the amount delivered and the resources required by a self-sustaining arc are correctly estimated, we do not anticipate any systematic bias in estimates of the cost associated with the logistics burden for self-sustaining arcs.

When self-sustaining arcs are part of a longer transportation chain, however, an important source of bias is introduced.

A Transportation Chain

A transportation chain is a sequence of nodes and arcs, as shown in Figure 2.

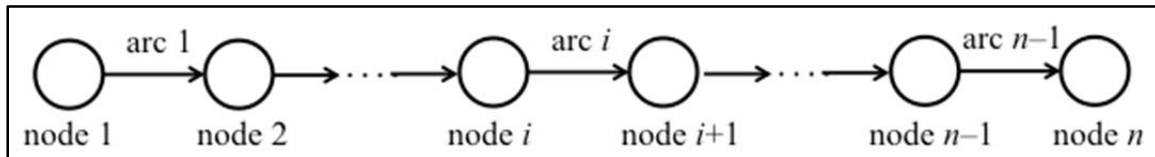

Figure 2. A Transportation Chain With n Nodes

We will use the word “stage” to refer to a node and its following arc. Building on the simple two-node model in Figure 2, and continuing to consider only a single resource (e.g., fuel), we let λ_i represent the multiplier for stage i . The total amount of supply required at node 1 per unit delivered to node n is the product of $n - 1$ multipliers; that is, in order to deliver one gallon of fuel to node n , we need

$B_n = \prod_{i=1}^{n-1} \lambda_i$ gallons of fuel at node 1. The extra fuel, $B_n - 1$, is consumed by logistics activities.

It is important to notice—and is often overlooked—that the impact of changing the efficiency of a single stage is compounded by the multipliers on the other stage. A reduction in fuel requirement by Δ_k in a single stage k reduces the overall fuel

requirement by $\left(\prod_{i=1}^{k-1} \lambda_i \right) \Delta_k$. A reduction in warfighter demand by Δ_n , as mentioned

above, reduces the overall fuel requirement by $\left(\prod_{i=1}^{n-1} \lambda_i \right) \Delta_n$.

In multistage transportation chains, the total amount of resources consumed increases geometrically with the number of stages. Estimates of FBCF obtained from early models did not account for the multiplier effect and provided systematic underestimates of the total amount of resources needed (Regnier, Simon, Nussbaum, & Whitney, in press).

Multiple Resources

It is likely that multiple resources are consumed by logistics activities, as opposed to fuel only. The approach discussed previously can be extended to a supply chain that transports multiple types of resources. Assume that there are m types of resources transported and/or consumed by this supply chain, and let resource c represent an arbitrary resource. Assume also that all resources can be



measured in the same units, either by weight or by volume. We define the following additional parameters:

x_n^c — the amount of resource c needed at the destination (an exogenously given requirement)

x_i^c — the amount of resource c required at node i .

X_i — the total resource requirement at node i . Note that $X_i = \sum_{c=1}^m x_i^c$.

r_i^c — the amount of resource c consumed per unit distance on stage i .

R_i — the total amount of resources consumed per unit distance on stage i .

Note that $R_i = \sum_{c=1}^m r_i^c$.

y_c — the unit cost of purchasing/producing resource c at the start of the supply chain

a_i — the cost of non-consumable items (e.g., labor, vehicle depreciation) required by stage i per unit of resources delivered to node $i + 1$

In addition, we will index d and w by stage, as d_i and w_i .

Given this expanded model, we can express x_i^c as

$$x_i^c = x_{i+1}^c + 2 \underbrace{\frac{X_{i+1}}{w_i - 2d_i R_i}}_{\substack{\text{amount of} \\ \text{resource } c \\ \text{consumed} \\ \text{in transport on} \\ \text{stage } i}} d_i r_i^c. \quad (1)$$

Equation 1 is defined recursively; that is, the amount of resources required is a function of the amount of resources required at the subsequent node. Further details of the computation required to determine Equation 1 and several of the subsequent expressions are given in Regnier, Simon, Nussbaum, Apte, and Khawam (2013). Carrying out the recursive computations allows us to calculate the total cost C of warfighter supply plus logistics as

$$C = \sum_{c=1}^m x_1^c y_c + \sum_{i=1}^{n-1} a_i X_{i+1}. \quad (2)$$

To capture the interactions among resources, we can compute a *cross-resource factor*, χ_i^c which specifies the change in the requirement of resource c at node i given a marginal increase in the requirement of a different resource at node



$i + 1$. It is obtained by differentiating the right-hand side of Equation 1 with respect to $x_{i+1}^{c'}$ for some $c' \neq c$. The result is

$$\chi_i^c = \frac{2d_i r_i^c}{w_i - 2d_i R_i}. \quad (3)$$

It is also possible to compute a *stage multiplier* for stage i , designated as Λ_i , which represents the increase in the total resource requirement at node i associated with a marginal increase in the total resource requirement at node $i + 1$. The stage multiplier can be expressed as

$$\Lambda_i = 1 + \frac{2d_i R_i}{w_i - 2d_i R_i}. \quad (4)$$

Since Λ_i can be computed for every stage in the chain, Equations 3 and 4 allow us to determine the impact of a given change in consumption on the consumption of any resource at any point in the chain. Given two nodes i and j ($i < j$), we can construct analogous terms Λ_{ij} and χ_{ij}^c , defined as follows:

$$\Lambda_{ij} = \prod_{i'=i}^{j-1} \Lambda_{i'} \quad (5)$$

$$\chi_{ij}^c = \sum_{i'=i}^{j-1} \left(\chi_{i'}^c \prod_{j'=i'+1}^{j-1} \Lambda_{j'} \right) \quad (6)$$

Λ_{ij} represents the marginal total resource requirement at node i given a marginal increase in the total requirement at node j , and $X\chi_{ij}^c$ represents the marginal increase in the requirement for resource c at node i given a marginal increase in the requirement of a different resource at node j . From Equation 4, it is clear that $\Lambda_i > 1$. Therefore, it must be true that Λ_{ij} is increasing in j (and decreasing in i). This implies that resource requirements are increasing in the length of the chain; adding a stage to the beginning or end of an existing chain cannot decrease overall cost, nor can it decrease demand for any individual resource.

Consider the case where $i = 1$. The only cross-resource factors needed to compute the demand for resource c at node 1 are $\chi_1^c, \dots, \chi_{j-1}^c$; the stage multipliers capture all of the other relevant interactions among the resources. Thus, the computation needed to determine the overall impact of a change in consumption is tractable, even for very long chains with a large number of resources. We are now able to construct a non-recursive expression for resource demands at the start of the chain for any resource c :



$$x_1^c = x_n^c + \chi_{1n}^c X_n. \quad (7)$$

Note that the derivative of the right hand side of Equation 7 with respect to $X_n^{c'}$ is χ_{1n}^c for any $c' \neq c$; this is consistent with the definition of χ_{ij}^c . Determining χ_{1n}^c for each resource is extremely helpful; it indicates the additional amount of the resource required at the start of the chain for a one-unit increase in the amount of a (different) resource consumed at the end of the chain.

There is a special case in which a supply chain transporting multiple resources can be simplified to the single-resource case. This occurs when the relative rates of consumption of the different resources are equal for all stages. If this condition holds, we would simply consider a single composite resource which consists of each resource in a proportion corresponding to its relative rate of consumption. This simplified approach will provide a good estimate of total costs and resource requirements if similar vehicles or convoys are used throughout the entire chain.

A Logistics Network

Although multistage FBC estimates typically model a chain, in fact, military logistics typically include a network with multiple warfighter positions and intermediate depots, as in **Error! Reference source not found.**, as well as more complicated geographic networks in which each node may have many direct sources.



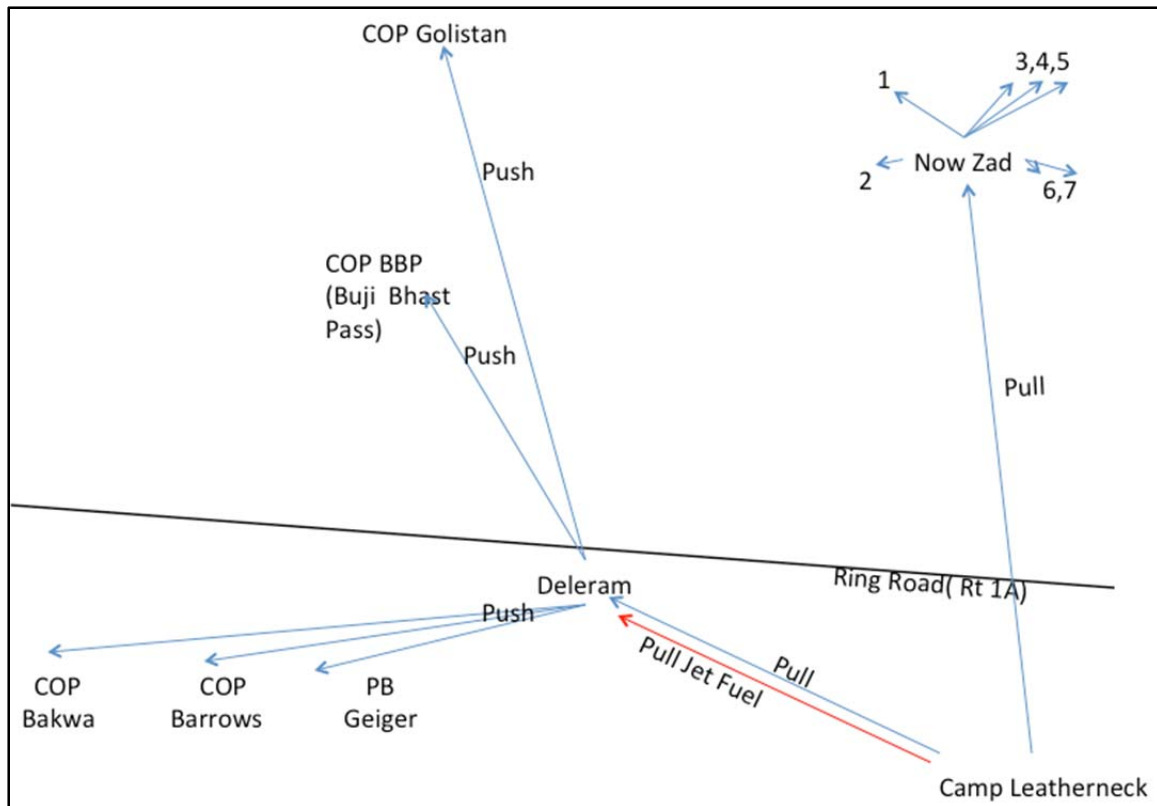

Figure 3. Schematic of a Portion of USMC Organic Logistics Network in Afghan's Helmand Province in 2009, Developed by Sean R. Dubbs (2011)

Extending our approach to model a logistics network is relatively straightforward. **Error! Reference source not found.** and **Error! Reference source not found.** show an example. Arcs 1–6 have associated stagewise multipliers λ_1 through λ_6 .

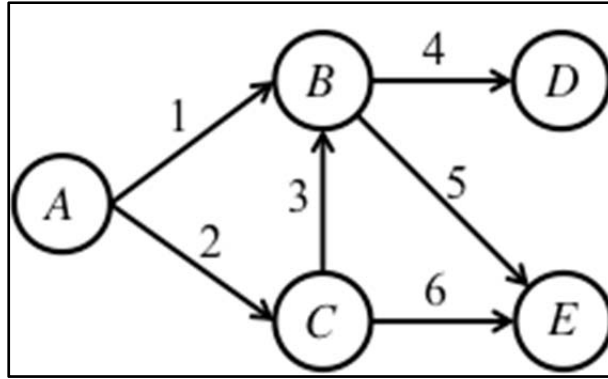

Figure 4. Schematic of a Hypothetical Logistics Network

Table 1. Input–Output Formulation of the Logistics Network Shown in
Error! Reference source not found.

		Input-output coefficients, a_{ij}				
		proximate destination node j				
		A	B	C	D	E
proximate source node i	A	0	$\alpha_1 \lambda_1$	λ_2	0	0
	B	0	0	0	λ_4	$\alpha_5 \lambda_5$
	C	0	$\alpha_3 \lambda_3$	0	0	$\alpha_6 \lambda_6$
	D	0	0	0	0	0
	E	0	0	0	0	0
	x	x_A	x_B	x_C	x_D	x_E

For nodes that receive supply along more than one arc, the α parameters indicate the relative proportions of supply received from the two proximate source (predecessor) nodes; the sums of the α parameters incident to a given node must be one. For example, node B receives a proportion α_3 of its supply from node C and α_1 of its supply from node A , with the requirement that $\alpha_1 + \alpha_3 = 1$.

In this model, we will assume that nodes are either pure source nodes (here, node A), transshipment nodes (B and C), or pure demand nodes (D and E). For demand nodes, we change the assumption made previously of unit demand to reflect the fact that the two demand nodes might need different quantities over a given period of time. If, for example, node D has much greater requirements than E , most of the cost associated with arcs 1 and 3 (and 2) should be attributed to the

demand at D . Therefore x_D and x_E are exogenous based on per-unit-time demand quantities at the two locations.

Mass-balance requires that the following system of equations holds:

$$x_i = \sum_{j \in \{A, B, C, D, E\}} a_{ij} x_j \text{ for } i = \{A, B, C\} \quad (8)$$

The above set of equations completely determines the system. To meet the demand precisely, and given the proportions dictated by the α parameters, the source and transshipment nodes' outputs are determined. Note that x_A is the total amount of supply required by the system.

In a network, the multiplier effects still apply—any unit of supply that passes along a particular route, for example, from node A by arc 1 to node B and then by arc 5 to node E —will still incur a multiplier that is the product of the stagewise multipliers. Specifically, any unit of supply to node E would incur a systemwide cost (i.e., demand at node A) equal to $\lambda_1 \lambda_5$. However, the marginal cost of supply at node E would be a weighted sum of the supply traveling along the three routes (chains), that is, $A \rightarrow C \rightarrow E$, $A \rightarrow C \rightarrow B \rightarrow E$ and $A \rightarrow B \rightarrow E$.

The system of equations in Equation 1 will appropriately calculate the allocation, and the weighted average resource requirement per unit at E may be calculated in a number of ways. One is by calculating the vector x using a shortest path algorithm and looking at the dual on the constraint $x_E = 1$. The impact of any parameter change in the network, such as an improvement in a given arc's efficiency, may easily be calculated once the model and its parameters (as in Table 1) are completed. Allocation of costs happens through this system of equations, which solves one of the challenges of FBC estimates. Allocation is proportional to the quantity of flow on each arc.

In addition to representing a geographic network, this extension can be used to model transportation between the same pair of nodes but by different modes, as in **Error! Reference source not found.** for transportation between Camp Leatherneck and Deleram. For example, let nodes C and B be collocated, but B indicates departure by aircraft. If air transport is more resource-intensive, then $\lambda_5 > \lambda_6$. α_5 and α_6 may be determined by capacity restrictions on the less costly arc, or they may reflect the need to transport sensitive items like specialized spare parts or ammunition by a more secure mode, in this case air, and therefore be determined by the relative demand for sensitive items. In this case $\lambda_3 > 1$ to account for resources consumed in handling or loading materials for air transport, or other special handling associated with these items, or if resources consumed for handling are negligible, $\lambda_3 = 1$.



The Army and contractor FBC tools call for specifying ordered stages and, to our knowledge, do not provide an easy way to model multimode transportation for different supply types. Their development process in each case started with single-resources modeling. Significant extensions would be required to capture allocation across routes and modes or interaction effects caused by consumption of multiple resources.

Burden of Force Protection

As highlighted in the *DAG* (DoD, 2013), the logistics footprint is especially important in high-threat environments. In such environments, significant portions of the transportation chain will be organic, and since there is no commercial access to fuel, the vulnerable logistics network may require force protection to ensure successful delivery. In this section, we summarize the analysis of the force-protection requirement on the total fuel requirement in a single-resource transportation chain, which is reported in greater detail in Regnier, Simon, Nussbaum, & Whitney (in press).

In a high-threat environment, an inverse relationship exists between force protection and asset attrition. In our work, we model the additional costs imposed by such environments through force protection and assume implicitly that the level of force protection is sufficient for the given environment. If it were not sufficient, we would observe higher costs due to attrition. For each stage, the transport function and the force-protection function for each stage are modeled as two distinct components. The origin is also interpreted as a component; when the model specifies that a component requires output from the origin, this means the output must be provided at the start of the transportation chain. As before, the transport component's output in each stage is the fuel delivered to the end of the stage. The force-protection component's output, on the other hand, is a measure of the amount of force protection provided on that stage; we use vehicle-hours. This is a relatively simple measure. For example, if a convoy requires two force-protection vehicles for a 60-mile stage, the force-protection requirement is 120 vehicle-miles.

Each component may require output from more than one other component to be used as input. Specifically, each force-protection component requires fuel provided by the preceding stage's transport component. Each transport component requires both fuel provided by the preceding stage's transport component, and force protection provided by the same stage's force-protection component. The notation is as follows:

i, j indices of components

x_i = the quantity of output produced by component i



a_{ij} = the amount of output from component i required by component j to produce one unit of component j 's output. The a_{ij} 's are the IO coefficients.

The mathematical expressions for a_{ij} require additional notation and differ depending on whether i and j are transport or force protection components. The detailed formulations are given by Regnier, Simon, Nussbaum, and Whitney (in press).

The amount of output required for each stage, x_i , is determined exogenously in the case of the final stage or determined by the solution to the set of mass-balance equations, given in Equation 9, for all i whose output is not exogenous:

$$x_i = \sum_j a_{ij} x_j . \quad (9)$$

An alternate perspective on modeling the logistical requirements imposed by force protection is to view force protection as personnel and platforms that must be diverted from warfighting activities to protect the logistics chain. With this perspective, we can express the impacts in terms of reduced warfighting capability rather than increased costs. As the amount of force protection required on a stage increases, the fuel multiplier increases dramatically, tending to infinity as force protection requirements approach the point where the logistics activities consume all of the fuel they are transporting. This phenomenon is sometimes called the “self-licking ice cream cone.” We provide detailed numerical examples of both perspectives in Regnier, Simon, Nussbaum, and Whitney (in press).

Threatened Sea Logistics

Transport by sea is highly efficient when it is unopposed. Although the U.S. Navy has operated nearly unopposed since the end of WWII and operates its logistics assets very efficiently without need for protective escorts, the experiences during WWII demonstrate that supply lines, and especially fuel, are a key vulnerability that a capable enemy can exploit to undermine and potentially defeat U.S. forces. Moreover, the 2010 *Quadrennial Defense Review Report* guidance anticipates the need to operate logistics under threat (DoD, 2010, p. 31).

As Hills (2011) had shown previously, the actual costs for the DLA–E to provide fuel differs dramatically in different areas of the world, even in a non-threatened environment. In planning for threatened logistics at sea, the DoN must consider the possibility of organic delivery of fuel and other supplies to naval vessels and to the USMC, other services, and even partner nations' forces globally.

As part of the FY2013 effort, we worked with LT Brendon Hathorn, a master's student in the Naval Postgraduate School (NPS) Operations Analysis program to build a spreadsheet-based model of U.S. Navy logistics, together with protective



convoys, to estimate the multiplier effect of supply under threat. This model has been modified slightly since reported in Hathorn (2013).

Model

Motivated by historical experiences of the centrality of threats to fuel supply lines in WWII strategy and the potential for U.S. naval operations in high-threat (anti-access) environments anticipated by the 2010 *Quadrennial Defense Review Report* (DoD, 2010), as LT Hathorn's thesis project, we collaborated on the development of the Naval Threat-Based Fully Burdened Cost Model (NTFBCM).

The NTFBCM is IO-based and calculates the IO multipliers as a function of threat scenarios. More efficient convoys have a smaller proportion of escorts per logistics vessel. However, convoy sizes may be restricted by port capacity and by the short-term requirements of the combat vessels and their capacities to replenish.

Network

The NTFBCM utilizes the global network model used in the Combat Logistics Force Planner (CLFP), shown in **Error! Reference source not found.** and described in Brown and Carlyle (2008). Nodes are indexed by i and j , and arcs connect the nodes. A destination node, j^D , may be anywhere on the globe, as specified by the user in the dialog box shown in **Error! Reference source not found.**, and is connected to the network by the addition of an arc to the nearest existing node. A dummy supply node, j^* , is also used in calculating the IO coefficients defined earlier in the section titled Economic Input-Output Analysis. Arcs in the NTFBCM are defined differently in that each pair of geographic nodes may be connected by many directed arcs—one for each threat level ($t = \text{Low, Med, or High}$) and each direction. We refer to them as *stages* and denote them as $s_{i,j,k}$ = the stage transporting supply from node i to j , under threat level t .



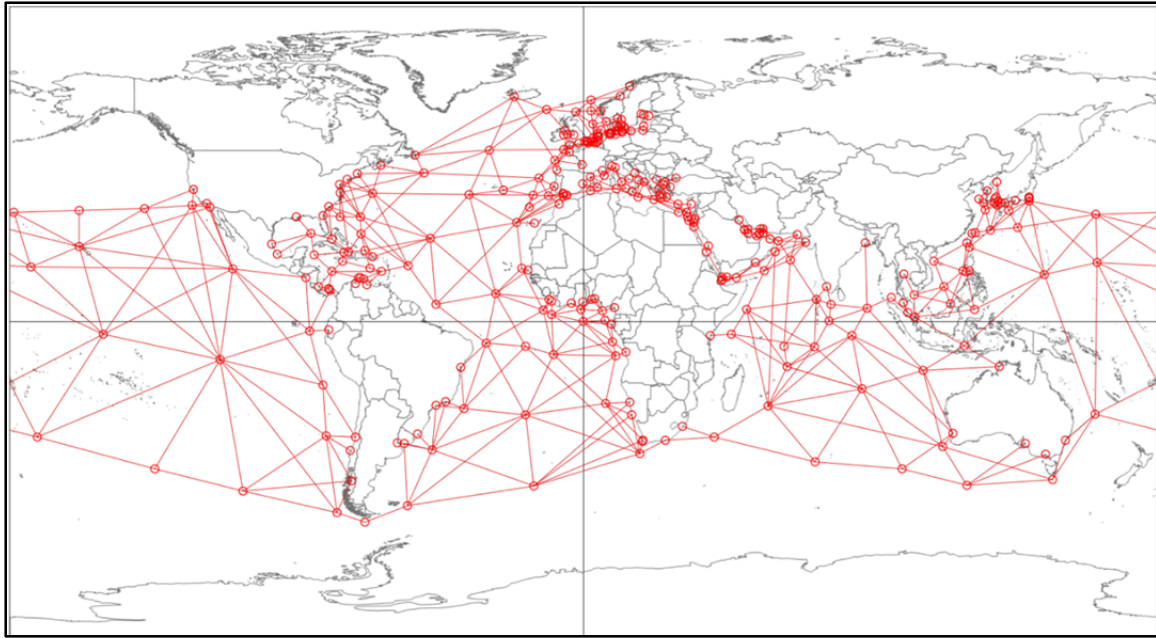

Figure 5. Global Network Model From CLFP

Note. Nodes are shown as circles, and arcs are shown as lines connecting them.



Figure 6. User Input Dialog Box in Naval Threat-Based Fully Burdened Cost Model

Consumption Rates

Each stage has a resources-consumption level that is estimated based on planning factors, also from the CLFP. **Error! Reference source not found.** shows a screen shot from the CLFP, with a sample of the planning factors. The planning factors for each vessel class (indexed k) are the daily consumption rates of each type of supply—fuel (jet fuel and diesel fuel), dry stores, and ordnance. Fuel is by far the dominant supply type; for example, for a guided-missile destroyer (DDG), over 95% of daily supply consumption is fuel (by weight). Therefore, in the current implementation of the NTBFBCM, all supply is normalized by weight so that all units are in short tons, and the consumption rates are denoted as r_k = daily consumption rate of normalized resources by vessel class k [short tons/day].

CLF		Ship Planning Factors									
		Data <input type="button" value="Apply Filters"/>									
ShipType	Commodity	Capacity	InTransit	AtAnchor	Docked	OnStation	Training	PreAssault	Assault	Sustain	
CVN	DFM	0	0	0	0	0	0	0	0	0	
CVN	JP5	74,642	3000	0	0	4000	4000	3000	5000	4000	
CVN	STOR	1,710	53	53	53	53	53	53	53	53	
CVN	ORDN	1,765	2.5	0	0	5	20	15	150	100	
CG	DFM	15,032	757	151.4	151.4	605.6	757	1429	757	757	
CG	JP5	475	8.5	0	0	17	25.5	17	39	25.5	
CG	STOR	68	2	2	2	2	2	2	2	2	
CG	ORDN	94	0.075	0	0	0.15	0.6	0.6	5	3	
DDG	DFM	10,518	646	129.2	129.2	518.8	646	1200	646	646	
DDG	JP5	475	8.5	0	0	17	25.5	17	34	25.5	
DDG	STOR	55	2	2	2	2	2	2	2	2	
DDG	ORDN	48	0.05	0	0	0.1	0.4	0.4	3	2	
FFG	DFM	4,286	304	60.8	60.8	243.2	304	600	304	304	
FFG	JP5	475	8.5	0	0	17	25.5	17	34	25.5	
FFG	STOR	35	1	1	1	1	1	1	1	1	
FFG	ORDN	16	0.02	0	0	0.0375	0.15	0.15	1	0.75	
LCS	DFM	2,663		72	0.2	288		360	180	180	
LCS	JP5	579		0		19	19	0	1	0.5	
LCS	STOR	5	0.25	0.25	0.25	0.25	0.25	0.25	0.25	0.25	
LCS	ORDN	20	0.025	0	0	0.05	0.2	0.2	2	1	
LHD	DFM	43,091	1071	214.2	214.2	856.8	1071	2000	1071	1071	
LHD	JP5	14,452	72	0	0	512	512	72	759	512	
LHD	STOR	520	15	15	15	15	15	15	15	15	
LHD	ORDN	391	0.45	0	0	0.9	3.6	3.6	33	18	
LHA	DFM	45,125	1071	214.2	214.2	856.8	1071	2000	1071	1071	
LHA	JP5	10,450	72	0	0	512	512	72	759	512	
LHA	STOR	641	15	15	15	15	15	15	15	15	
LHA	ORDN	391	0.45	0	0	0.9	3.6	3.6	33	18	
LPD4	DFM	17,700	528	105.6	105.6	422.4	528	1142	528	528	
LPD4	JP5	443	17	0	0	221	221	17	324	221	
LPD4	STOR	187	5	5	5	5	5	5	5	5	
LPD4	ORDN	88	0.1	0	0	0.2	0.8	0.8	6	4	
LPD17	DFM	23,750	1071	214.2	214.2	856.8	1071	2000	1071	1071	
LPD17	JP5	6,785	17	0	0	512	512	17	759	512	
LPD17	STOR	195	6	6	6	6	6	6	6	6	
LPD17	ORDN	88	0.1	0	0	0.2	0.8	0.8	6	4	

Figure 7. Examples of Ship Planning Factors From the Combined Logistics Force Planner

The impact of threat level on resource consumption is based on the assumption that CLF vessels are protected by an escort of combat vessels. The convoy composition for each threat level is denoted as $v_{k,t}$ = number of vessels of class k in the convoy under threat level t , assumed constant within a scenario.

Scenario

A scenario consists of

- the position of warfighter demand (for fuel or any other supply);
- the availability or non-availability of ports as sources of supply; and
- a threat level for each arc (pair of nodes).

For a given scenario, the NTBFCM estimates the total amount of supply from source nodes required per unit of supply delivered to the warfighter. The results show how the total resources requirements increase with the length of the supply chain and with the force-protection requirements, and increase as supply nodes become unavailable due to threat. This implies that the value of reducing warfighter fuel requirements is higher than estimated in a low-threat scenario. The Navy has counted on uncontested supply lines for decades; therefore, historical costs to deliver fuel to forward-deployed ships will not reflect the costs in an access-denial scenario.



Input–Output Model

The NTBFBCM uses an IO sub-model to estimate the total resource requirement (TRR) at each node and ultimately for the entire network, associated with a particular scenario, per unit delivered to the warfighter (enduser). **Error! Reference source not found.** shows that there may be many possible routes that supply could take through the network. The NTBFBCM choose one such route and models the transportation from the source to the warfighter as a supply chain, as in **Error! Reference source not found.**. A linear programming optimization was used to select a single route through the network, for a given scenario. This route becomes the transportation chain. The selected chain minimizes the sum of arc costs for supply traveling from the source (also selected by the optimization) to the warfighter position. If stage s is used in the selected route, the decision variable z_s is set to one, and zero otherwise.

Now the IO coefficients for each pair of stages (components) can be calculated as

$$a_{s',s} = z_s (1 + R_s), \quad (10)$$

where R_s is the total resource consumption on stage s per unit delivered to its endpoint. In order for the network to be in balance, each stage must deliver an amount x_s = the total amount of output required of stage s , per short ton of supply delivered to node $j(s)$. The IO equations are therefore

$$x_s = \sum_{s':i(s')=j(s)} a_{s,s'} x_{s'}, \forall s \quad \text{except } s \text{ that terminate in } j^D \text{ (the warfighter demand node)}. \quad (11)$$

The Total Resource Requirement (TRR) of the logistics system is the total supply requirement at source nodes per unit of supply delivered to the destination, and it is equal to x_{s^*} , where $i(s^*) = j^*$ (the dummy source node).

The TRR is unitless and is a ratio of supply required by the system to supply delivered. It is not in units of dollars—as FBC estimates are supposed to be, according to the *DAG* (DoD, 2013). However, it can be argued that the resource requirements are more important than costs, especially in time of war. In time of war, it is often the ability to get supplies at any price that is in question, not the ability to procure them within a budget. In the case of fuel, many important impacts, including the dependence on foreign sources and environmental impacts, are related to the total quantity of fuel used, rather than on its market price, which is simply a reflection of the marginal value in the marketplace at a given time.



Operating and Support Costs

While the NTBFBCM may be used to estimate the total amount of supply required by the logistics system per unit delivered to the warfighter, FBC includes other cost elements as well. Moreover, these other elements are also affected by the multiplier effect; specifically, for long paths from source node to destination node, the early stages will need to deliver larger amounts of supply to sustain later stage logistics activities. The other cost elements should go up proportionally with the amount of supply that early stages deliver. The NTBFBCM estimates the days required by Military Sealift Command vessels and combat escorts for a single delivery by the convoy, and the results may therefore be used in combination with estimates of the cost to operate those vessels to produce an estimate of the FBC of a single round-trip or one-way delivery. In order to avoid double-counting the cost of supplies that are captured in the total resource requirement, cost elements for fuel and other supplies must be properly excluded and then added in at the correct amount—based on the TRR—and at the procurement price at the source node. Hathorn (2013, Section 3.3) provides examples. The NTBFBCM may be used to evaluate the impact of the unavailability of source nodes, such as Singapore, and of threat levels requiring escort on all or portions of the network.

Combining Air, Land, and Sea

Each of the above-described models represents just a portion of the supply chain, especially during wartime.

In the Afghanistan scenario in Figure 3, there is a long land-based supply chain. Some of the supplies—such as sensitive supplies like ammunition—could not be procured locally even at Camp Leatherneck (modeled as the source node), and instead originated in the contiguous United States.

In a wartime scenario, even supplies like fuel may be difficult or impossible to obtain commercially at sources that the DoN and DLA–E use in peacetime. Therefore, the *DAG* (2013) guidance that “For purposes of calculating ADP, the ‘standard price’ [i.e., DLA–E standard price] shall be used” (Section 3.1.6) systematically underestimates—possibly by a factor of two—the true cost (even aside from other sources of bias).

While van Creveld attributes it to the long land-based supply line in Africa, others have attributed Rommel’s ultimate failure in North Africa to the devastating and resource-intensive battle on the Mediterranean. Regardless of the relative importance of the African and Mediterranean portions of the supply network, the impact of either is multiplicative with the effect of the others. By far, the primary sources for this supply network were inside Europe and thus the network included railways that were under frequent bombing attack in Europe, the threatened



Mediterranean shipping, and the long African land route. Moreover, force protection was a major resource demand, including air support from the Luftwaffe. There were also substantial losses due to attacks on vessels in the Mediterranean; rail transport to the ports on the European side (also under attack) were also part of this supply network (van Creveld, 2004).

Humanitarian and Disaster Relief

In humanitarian and disaster relief (HADR) missions, the transportation network must frequently be set up in an austere environment. Generally, the supply network includes sources in normal environments, at which the resources required by logistics activities are locally available. However, both handling (warehousing and transshipment) nodes and transportation arcs and distribution nodes are often in austere environments. HADR missions face additional challenges, in common with new theaters for military operations, such as the need to set up a transportation network rapidly, uncertainty about the amount of demand and the type of resources demanded, and urgent needs. All of these contribute to inefficiency in the network.

In related work under the title of *Issues and Challenges in Self-Sustaining Response Supply Chains* (Apte, Khawam, Regnier, Simon, & Nussbaum, 2013a), we modeled the impact of self-sustainment on the costs associated with HADR logistics networks and, in particular, the interaction between the self-sustainment multiplier effect and two dimensions of the complexity of a HADR network—speed and dispersion (Apte & Yoho, 2011). We found that these factors are all positively interrelated. HADR missions with urgent demands and/or more dispersed demand have a larger multiplier effect. The multiplier effect of self-sustainment not only adds to but compounds the effect of complexity—in terms of speed and dispersion—on costs.

This indicates that investments in the resource efficiency of HADR logistics assets and processes are especially valuable. Our analysis shows that resource demands associated with logistics operations are more important than their direct purchase cost indicates, because in a self-sustaining supply network, those resources incur indirect costs of transport to their point of use. A platform, such as an amphibious vessel, that has a high up-front cost but a relatively lower operational resource requirement, may be more cost-effective than a cheaper but more resource-intensive option. Understanding the effect of self-sustainment and complexity of operations on the cost is one way to improve strategic planning for disaster response.

This work is reported in Apte, Khawam, Regnier, Simon, and Nussbaum (2013a) and the concurrent Acquisition Research Program report (Apte, Khawam, Regnier, Simon, & Nussbaum, 2013b) on self-sustaining response supply chains.



Deployment Phase

An important element missing from our models so far is the deployment phase, that is, the logistics effort required to bring logistics and associated protection assets into theater. Other FBC tools do attempt to include the deployment phase. This phase can require substantial resources, as when mine-resistant ambush protected (MRAP) vehicles were transported to Afghanistan by air and used to protect fuel and water convoys. Stockfish (1991) described the WWII Royal Air Force ferry systems that used five or six legs to bring aircraft from the Gold Coast to blockaded Egypt, as well as other similar ferry systems. This is an important area for future work.

Conclusions and Recommendations

Based on three years of research on the implications of the feedback of logistics burdens associated with supplying the warfighter, we offer the following conclusions and recommendations:

- Tools currently in development and in use systematically underestimate the FBCS by neglecting the interaction across different resources.
- Incorporating the interactions among and between resources is challenging given the modular approach that FBC tools are using.
- Resource-intensive (inefficient) logistics activities are more costly than naïve analysis will show.
- Using the DLA–E standard price for fuel may be problematic for wartime scenarios; it will tend to underestimate the true FBCS for forward engagements.
- Standardizing requirements for data specification and collection on resource consumption by DoD and DoN suborganizations would be beneficial.
- Our approach to estimating fully burdened costs could be expanded to include the deployment phase; this is particularly relevant for operations of very short duration, as the deployment phase will represent a large proportion of total cost.
- Our approach to estimating fully burdened costs could be expanded to get better estimates of the true organization-wide cost of providing capability by attributing fixed overhead costs; for example, activities



like recruiting and training are required to have the personnel needed to operate these logistics networks.



THIS PAGE INTENTIONALLY LEFT BLANK



References

- Apte, A., Khawam, J., Regnier, E., & Simon, J. (2013). *Complexity and self-sustainment in disaster response supply chains*. Manuscript submitted for publication.
- Apte, A., Khawam, J., Regnier, E., Simon, J., & Nussbaum, D. (2013a, April 1). Issues and challenges in self-sustaining response supply chains. In *Proceedings of the 10th Annual Acquisition Research Symposium* (Vol. II; [NPS-LM-13-C10P05R06-064](#)). Retrieved from <http://acquisitionresearch.net>
- Apte, A., Khawam, J., Regnier, E., Simon, J., & Nussbaum, D. (2013b, September 28). *Issues and challenges in self-sustaining response supply chains* (NPS-LM-13-107). Retrieved from <http://www.acquisitionresearch.net/files/FY2013/NPS-LM-13-107.pdf>
- Apte, A., & Yoho, K. D. (2011). Strategies for logistics in case of a natural disaster. In *Proceedings of the 40th Annual Meeting of Western Decision Sciences Institute*. Portland, OR.
- Assistant Secretary of Defense for Operational Energy Plans and Programs (ASD[OEPP]). (2013). *FY 2011 operational energy annual report*. Washington, DC: Department of the Army. Retrieved from http://energy.defense.gov/Portals/25/Documents/Reports/20130311_FY2011OperationalEnergyAnnualReport.pdf
- Baumol, W. J., & Wolff, E. N. (1981). Subsidies to new energy sources: Do they add to energy stocks? *The Journal of Political Economy*, 85(5), 891–913.
- Brown, G. G., & Carlyle, W. M. (2008). Optimizing the U.S. Navy's Combat Logistics Force. *Naval Research Logistics*, 55(8), 800–810.
- Carter, W. R., Kimball, D. A., & Spruance, R. A. (1953). *Beans, bullets, and black oil*. Retrieved from <http://www.ibiblio.org/hyperwar/USN/BBBO>
- Defense Science Board (DSB). (2001). *More capable warfighting through reduced fuel burden*. Washington, DC: Office of the Under Secretary of Defense for Acquisition, Technology, and Logistics.
- Defense Science Board (DSB). (2008). *More fight—Less fuel*. Washington, DC: Office of the Under Secretary of Defense for Acquisition, Technology, and Logistics.
- DeGrange, W. C. (2005). *Optimizing global combat logistics force support for sea base operations* (Doctoral dissertation). Monterey, CA: Naval Postgraduate School.



- Department of Defense (DoD). (2010, February). *Quadrennial defense review report*. Retrieved February 7, 2013, from <http://www.defense.gov/qdr>
- Department of Defense (DoD). (2013, May 7). *Defense acquisition guidebook*. Retrieved June 22, 2013, from <https://dag.dau.mil/Pages/Default.aspx>
- Dietzenbacher, E., & Lahr, M. L. (Eds). (2004). *Wassily Leontief and input-output economics*. Cambridge, UK: Cambridge University Press.
- Dubbs, S. R. (2011). *Estimating the fully burdened cost of fuel using an input-output model—A micro-level analysis* (Master's thesis). Monterey, CA: Naval Postgraduate School.
- Duncan Hunter National Defense Authorization Act for Fiscal Year 2009, Pub. L. No. 110-417, 122 Stat. 4356 (2008, October 14).
- Eady, D. S., Siegel, S. B., Bell, R. S., & Dicke, S. H. (2009). *Sustain the Mission Project: Casualty factors for fuel and water resupply convoys, Final technical report*. Retrieved from Army Environmental Policy Institute website: http://www.aepi.army.mil/docs/whatsnew/SMP_Casualty_Cost_Factors_Final_1-09.pdf
- Gue, K. R. (2003). A dynamic distribution model for combat logistics. *Computers & Operations Research*, 30(3), 367–381.
- Haggerty, A. E. (2008). *S&T and maneuver warfare: A current success and a future challenge*. Retrieved from Defense Technical Information Center website: www.dtic.mil/ndia/2008maneuver/Haggerty.pdf
- Hathorn, B. (2013). *Resource burden of logistics to Navy ships under threat scenarios* (Master's thesis). Monterey, CA: Naval Postgraduate School.
- Hills, J. (2011). *Modeling the DOD bulk fuels supply chain using input output analysis* (Master's thesis). Monterey, CA: Naval Postgraduate School.
- Hoekstra, R., & van den Bergh, J. C. (2006). Constructing physical input–output tables for environmental modeling and accounting: Framework and illustrations. *Ecological Economics*, 59(3), 375–393.
- Leontief, W. (1986). *Input-output economics* (2nd ed.). New York, NY: Oxford University Press.
- Marangoni, G., & Fezzi, G. (2002). Input-output for management control: The case of GlaxoSmithKline. *Economic Systems Research*, 14(3), 245–256.
- Regnier, E. D., & Nussbaum, D. A. (2011). Theory and feasibility of implementing economic input/output analysis of Department of Defense to support acquisition decision analysis and cost estimation. In *Proceedings of the*



Eighth Annual Acquisition Research Symposium (Vol. II). Retrieved from <http://www.acquisitionresearch.net/beta/files/FY2011/NPS-AM-11-C8P15R03-057.pdf>

Regnier, E., Simon, J., & Nussbaum, D. (2012). Estimating logistics burdens in support of acquisition decisions. In *Proceedings of the Ninth Annual Acquisition Research Symposium* (Vol. II; [NPS-AM-12-C9P24R01-091](#)). Retrieved from <http://acquisitionresearch.net>

Regnier, E., Simon, J., & Nussbaum, D. (2013). *Estimating supply-chain burdens in support of acquisition decisions* (Technical Report NPS-LM-13-026). Retrieved from <http://acquisitionresearch.net>

Regnier, E., Simon, J., Nussbaum, D., Apte, A., & Khawam, J. (2013). Fully-burdened cost of supply in self-sustaining logistics networks. In *Proceedings of the Tenth Annual Acquisition Research Symposium* (Vol. II; [NPS-LM-13-C10P05R01-059](#)). Retrieved from <http://acquisitionresearch.net>

Regnier, E., Simon, J., Nussbaum, D., & Whitney, L. (in press). The fuel multiplier in fuel supply logistics. *Journal of Defense Modeling and Simulation*.

Rommel, E. (1982). *The Rommel papers*. Cambridge, MA: Da Capo Press.

Schwartz, M., Blakely, K., & O'Rourke, R. (2012, July 20). *Department of Defense energy initiatives: Background and issues for Congress* (CRS: R42558). Washington, DC: Library of Congress, Congressional Research Service.

Stockfish, J. A. (1991). *Linking logistics and operations: A case study of World War II air power* (RAND/N-3200-AF). Santa Monica, CA: RAND.

van Creveld, M. (2004). *Supplying war: Logistics from Wallenstein to Patton*. Cambridge, UK: Cambridge University Press.



THIS PAGE INTENTIONALLY LEFT BLANK





ACQUISITION RESEARCH PROGRAM
GRADUATE SCHOOL OF BUSINESS & PUBLIC POLICY
NAVAL POSTGRADUATE SCHOOL
555 DYER ROAD, INGERSOLL HALL
MONTEREY, CA 93943

www.acquisitionresearch.net