

NPS-AM-06-032



ACQUISITION RESEARCH SPONSORED REPORT SERIES

**Managing the Service Supply Chain in the Department of
Defense: Opportunities and Challenges**

30 December 2006

by

Uday Apte, Professor,

Geraldo Ferrer, Associate Professor,

Ira Lewis, Associate Professor, and

Rene Rendon, Senior Lecturer,

Graduate School of Business & Public Policy

Approved for public release, distribution unlimited.

Prepared for: Naval Postgraduate School. Monterey. California 93943



ACQUISITION RESEARCH PROGRAM
GRADUATE SCHOOL OF BUSINESS & PUBLIC POLICY
NAVAL POSTGRADUATE SCHOOL

The research presented in this report was supported by the Acquisition Chair of the Graduate School of Business & Public Policy at the Naval Postgraduate School.

To request Defense Acquisition Research or to become a research sponsor, please contact:

NPS Acquisition Research Program
Attn: James B. Greene, RADM, USN, (Ret)
Acquisition Chair
Graduate School of Business and Public Policy
Naval Postgraduate School
555 Dyer Road, Room 332
Monterey, CA 93943-5103
Tel: (831) 656-2092
Fax: (831) 656-2253
e-mail: jbgreene@nps.edu

Copies of the Acquisition Sponsored Research Reports may be printed from our website www.acquisitionresearch.org



ACQUISITION RESEARCH PROGRAM
GRADUATE SCHOOL OF BUSINESS & PUBLIC POLICY
NAVAL POSTGRADUATE SCHOOL

Abstract

The services acquisition volume in the US Department of Defense (DoD) has continued to increase in scope and dollars in the past decade. Between FY 1999 to FY 2003, DoD's spending on services increased by 66%, and in FY 2003, the DoD spent over \$118 billion (or approximately 57% of total DoD procurement dollars) on services. In recent years, the DoD has spent more on services than on supplies, equipment and goods, even considering the high value of weapon systems and large military items. These services belong to a very broad set of activities, ranging from grounds maintenance to space launch operations. The major categories include professional, administrative, and management support; construction, repair, and maintenance of facilities and equipment; information technology; research and development, and medical care.

As the DoD's services acquisition volume continues to increase in scope and dollars, the agency must pay greater attention to proper acquisition planning, adequate requirements definition, sufficient price evaluation, and proper contractor oversight. In many ways, these are the same issues affecting the acquisition of physical supplies and weapon systems. However, the unique characteristics of services and the increasing importance of services acquisition offer a significant opportunity for conducting research in the management of the service supply chain in the Department of Defense.

The objectives of the exploratory research presented in the paper are to (1) analyze the size, structure and trends in the DoD's service supply chain, (2) understand the challenges faced by contracting officers, program managers and end-users in services acquisition, (3) develop a conceptual framework for understanding and analyzing the supply chain in services, and (4) provide policy recommendations that can lead to more effective and efficient management of the DoD's spending on services. In addition to the analysis of service acquisition-related data and theory development, this research also includes empirical work in terms of



site visits and interviews at Navy, Army and Air Force bases.. Addressing issues related to both theory and practice, this paper makes a modest contribution towards more effective and efficient management of service acquisition in the Department of Defense.

Keywords: Service Supply Chain, Outsourcing, Contract Management



Acknowledgements

The authors are greatly thankful to RADM Jim Greene, USN (Ret), the NPS Acquisition Research Chair, for securing the sponsor funding for this research. We would also like to acknowledge Keith Snider for his efforts on behalf of the Acquisition Research Program in the Graduate School of Business and Public Policy of the Naval Postgraduate School.



THIS PAGE INTENTIONALLY LEFT BLANK



ACQUISITION RESEARCH PROGRAM
GRADUATE SCHOOL OF BUSINESS & PUBLIC POLICY
NAVAL POSTGRADUATE SCHOOL

About the Authors

Uday Apte is Professor of Operations Management at the Graduate School of Business and Public Policy, Naval Postgraduate School, Monterey, CA. Before joining NPS, Dr. Apte taught at the Wharton School, University of Pennsylvania, Philadelphia, and at the Cox School of Business, Southern Methodist University, Dallas. He is experienced in teaching a range of operations management and management science courses in the Executive and Full-time MBA programs.

Dr. Apte has served as a founder and President of the College of Service Operations, Production and Operations Management Society (POMS), as a board member of POMS, and as guest editor of *Production and Operations Management* journal. Areas of his research interests include managing service operations, supply-chain management, technology management, and globalization of information-intensive services. He has published over 30 articles, five of which have won awards from professional societies. His research articles have been published in prestigious journals including *Management Science*, *Interfaces*, *Production and Operations Management*, *Journal of Operations Management*, *Decision Sciences*, *IIE Transactions*, *Interfaces*, and *MIS Quarterly*. He has co-authored two books, *Manufacturing Automation* and *Managing in the Information Economy*.

Dr. Apte holds a PhD in Decision Sciences from the Wharton School, University of Pennsylvania. His earlier academic background includes a MBA from the Asian Institute of Management, Manila, Philippines, and a Bachelor of Technology (Chemical Engineering) from the Indian Institute of Technology, Bombay, India.

Dr. Uday M. Apte
Graduate School of Business and Public Policy
Naval Postgraduate School
Monterey, CA 93943-5000
Tel: 831-656-3598
Fax: (831) 656-3407
E-mail: umapte@nps.edu

Geraldo Ferrer is Associate Professor of Operations Management at the Naval Postgraduate School. Prior to joining NPS, he was in the faculty of the Kenan-Flagler Business School at the University of North Carolina for seven years. His areas of expertise include global operations, supply-chain management, sustainable technologies, product stewardship, reverse logistics and remanufacturing. He has also studied the reverse logistics required in recycling and remanufacturing operations, and inventory problems affecting products made in small batches for frequent deliveries. He has published on these topics in *European Management Journal*, *Management Science*, *Naval Research Logistics*, *IIE Transactions*, *Production and Operations Management*, *European Journal of*



Operational Research, International Journal of Production Economics, Ecological Economics, Business Horizons and Resources Conservation and Recycling. He is a contributor in the *Handbook of Environmentally Conscious Manufacturing* and *Handbook of Industrial Ecology.* He has presented his research in national and international conferences in four continents, and in invited seminars in various academic institutions.

Dr. Ferrer serves as reviewer for the National Science Foundation, many academic journals, and for the Social Sciences and Humanities Council of Canada. He has also reviewed textbooks in the areas of operations management, inventory management and project management. He received his PhD in Technology Management from INSEAD, his MBA from Dartmouth College, a mechanical engineering degree from the Military Institute of Engineering in Rio de Janeiro and a BA in Business Administration from Federal University of Rio de Janeiro. Dr. Ferrer was founder and director of Superserv, Ltd., a company that promoted technology transfer ventures between North American and Brazilian business, introducing innovative technology products for the petroleum industry. He has consulted for companies in the United States and in Brazil.

Geraldo Ferrer
Associate Professor
Graduate School of Business and Public Policy
Naval Postgraduate School
Monterey, CA 93943-5197
Tel: (831) 656-3290
E-mail: gferrer@nps.edu

Ira Lewis received a BA and MBA from the University of Ottawa in 1980 and 1982. From 1982 to 1998, he worked for Canada's Department of National Defence in acquisition- and logistics-related positions. Dr. Lewis received a PhD in Logistics and Operations Management from Arizona State University in 1992. Since joining the Naval Postgraduate School faculty as an Associate Professor in 1998, Dr. Lewis has taught courses in defense transportation and logistics management. His research interests include cultural change and organizational integration within military logistics systems and partnership programs between the DoD and the transportation industry. He is a recipient of a Certificate of Recognition for Outstanding Instructional Performance at NPS, and has authored or co-authored articles in *Transportation Journal*, the *Journal of Business Logistics*, the *International Journal of Physical Distribution and Logistics Management*, the *International Public Management Journal*, and the *Journal of Public Procurement*. Dr. Lewis also served as Associate Dean for Faculty Affairs in the NPS Graduate School of Business and Public Policy from October 2002 to March 2006.

Ira A. Lewis
Associate Professor
Graduate School of Business & Public Policy
Naval Postgraduate School
Monterey, CA 93943



Phone: (831) 656-2464
E-mail: jalewis@nps.edu

Rene G. Rendon is on the faculty of the Naval Postgraduate School where he teaches graduate acquisition and contract management courses. Prior to his appointment at the Naval Postgraduate School, he served for more than 22 years as an acquisition and contracting officer in the United States Air Force. His Air Force career included assignments as a contracting officer for major space launch systems and satellite programs, as well as the F-22 Advanced Tactical Fighter and the Peacekeeper ICBM. Rene also served as a contracting squadron commander and as a contracts manager for the NCR Corporation. Rene has earned Bachelor, Master, and Doctorate degrees in business administration, has taught for the UCLA Government Contracts program and was also a senior faculty member for the Keller Graduate School of Management.

Dr. Rendon has earned professional certifications from the National Contract Management Association (NCMA), the Institute for Supply Management (ISM), and the Project Management Institute (PMI). He has received the prestigious Fellow Award from NCMA, and he was recognized with the United States Air Force Outstanding Officer in Contracting Award. He has also received the NCMA National Education Award, the NCMA Outstanding Fellow Award, and the NCMA Charles J. Delaney Memorial Award for the best published article on contract management. Dr. Rendon is the Chair of ISM's Federal Acquisition and Subcontract Management Group, Chair of the ISM Certification Committee, as well as on the Editorial Review Board for the ISM Inside Supply Management. He is a member of the NCMA Board of Advisors, as well as associate editor for its *Journal of Contract Management*. Dr. Rendon has published articles in *Contract Management*, *the Journal of Contract Management*, *Program Manager*, *Project Management Journal*, and *PM Network*, and is co-author of *Contract Management Organizational Assessment Tools*, published in 2005, and *U.S. Military Program Management: Lessons Learned & Best Practices*, published in 2007.

Rene G. Rendon
Senior Lecturer
Graduate School of Business and Public Policy
Naval Postgraduate School
Monterey, CA 93945-5197
Tel: (831) 656-3464
E-mail: rgrendon@nps.edu



THIS PAGE INTENTIONALLY LEFT BLANK



ACQUISITION RESEARCH PROGRAM
GRADUATE SCHOOL OF BUSINESS & PUBLIC POLICY
NAVAL POSTGRADUATE SCHOOL

NPS-AM-06-032



ACQUISITION RESEARCH SPONSORED REPORT SERIES

**Managing the Service Supply Chain in the Department of
Defense: Opportunities and Challenges**

30 December 2006

by

Uday Apte, Professor,

Geraldo Ferrer, Associate Professor,

Ira Lewis, Associate Professor, and

Rene Rendon, Senior Lecturer,

Graduate School of Business & Public Policy

Disclaimer: The views represented in this report are those of the author and do not reflect the official policy position of the Navy, the Department of Defense, or the Federal Government.



ACQUISITION RESEARCH PROGRAM
GRADUATE SCHOOL OF BUSINESS & PUBLIC POLICY
NAVAL POSTGRADUATE SCHOOL

THIS PAGE INTENTIONALLY LEFT BLANK



ACQUISITION RESEARCH PROGRAM
GRADUATE SCHOOL OF BUSINESS & PUBLIC POLICY
NAVAL POSTGRADUATE SCHOOL

Table of Contents

I. Introduction	1
II. Service Characteristics and Their Implications to Contracting	4
A. Characteristics of Services	5
B. Service Quality.....	8
C. Service Characteristics and their Implications for Contracting	9
III. Size and Structure of the DoD’s Services Acquisition Environment	12
A. Growth and Scope of DoD Service Contracts.....	14
B. Services Contract Management—an Overview	18
IV. DoD Policy on Contracting for Services	22
A. The Challenge of Outsourcing Services	25
B. The “Human Capital” Issue	27
V. Site Visits	33
A. Presidio of Monterey	33
B. Travis Air Force Base	39
C. Naval Postgraduate School	42
VI. Conclusions	47
A. Discussion	49
References	51
Initial Distribution List	57



THIS PAGE INTENTIONALLY LEFT BLANK



ACQUISITION RESEARCH PROGRAM
GRADUATE SCHOOL OF BUSINESS & PUBLIC POLICY
NAVAL POSTGRADUATE SCHOOL

I. Introduction

The DoD's services acquisition volume has continued to increase in scope and dollars in the past decade. Between FY 1999 to FY 2003, the DoD's spending on services increased by 66%, and in FY 2003, the DoD spent over \$118 billion (or approximately 57% of total DoD procurement dollars) on services (GAO, 2005a). In recent years, the DoD has spent more on services than on supplies, equipment and goods, even considering the high value of weapon systems and large military items (Levy, D.G., Moini, J.S., Kaganoff, T., Keating, E.G., Augustine, C.H., Bikson, T. K., Leuschner, K.J., & Gates, S.M., 2004). These services belong to very broad set of activities, ranging from grounds maintenance to space launch operations. The major categories include professional, administrative, and management support; construction, repair, and maintenance of facilities and equipment; information technology; research and development, and medical care.

As the DoD's services acquisition volume continues to increase in scope and dollars, the agency must pay greater attention to proper acquisition planning, adequate requirements definition, sufficient price evaluation, and proper contractor oversight (GAO, 2002a). In many ways, these are the same issues affecting the acquisition of physical supplies and weapon systems. However, there are important differences between the production, acquisition and delivery of services and manufactured goods. For example, services cannot be inventoried, require customer contact and joint production, and have customer-specific inputs. Moreover, we observe intangibility in varying degrees, which makes it difficult to evaluate the quality and performance of a service operation (Karmarkar & Pitbladdo, 1995). The unique characteristics of services and the increasing importance of services acquisition offer a significant opportunity for conducting research in the management of the service supply chain in the Department of Defense.

The purpose of this research is, therefore, to conduct an initial exploratory analysis of DoD services acquisition so as to frame the totality of the DoD's services



acquisition environment. Our research contributes to both the theory and practice of service acquisition in the Federal Government. Theoretical contributions include the development of a conceptual framework for understanding and analyzing the supply chain in services, based on rigorous literature in operations management, logistics, public policy, budgeting and microeconomics. We expect that the knowledge developed herein will lead to more effective and efficient management of the Department of Defense acquisition of services.

This exploratory research effort consists of a review of the service acquisition practices in the Department of Defense. It includes visits to a sample of DoD installations involved in the acquisition of services, with interviews of contracting officers, program managers, and other personnel at these installations.

The literature review focuses on secondary sources such as government reports, defense acquisition-related periodicals and journals, as well as other scholarly and practitioner-oriented journals and periodicals dealing with service operations, outsourcing and contracting.

The DoD installation visits were planned to cover a sample of Army, Navy, and Air Force installations. Thus far, we have visited Travis AFB and the Presidio of Monterey and have visits to the Naval bases in San Diego planned in the near future. These DoD installations have outsourced significant operation-support services and provide an excellent source for analysis. During these visits, we explored the following research questions:

1. What types of base operations services are typically procured at military installations?
2. How is the outsourcing decision made in services acquisition?
3. How are these services acquired (what type of acquisition strategy and procurement method is used)?
4. What are the challenges in procuring base operations-support services, from both business (acquisition, finance) and operational (military, mission) perspectives?



5. What type of management structure is used to manage these service programs?
6. What are the emerging trends in the policies and practices used in acquiring base operations services?

This research paper is organized in six sections. This introductory section is followed by the second section dealing with the inherent characteristics of services and their implications to contracting. We analyze the size and structure of the DoD's service acquisition environment in the third section. An overview of services contract management is also presented in this section. The fourth section presents our analysis of the DoD's policy and practices on contracting for services. The information we gathered during our site visits is discussed in the fifth section. The preliminary observations and conclusions of this exploratory research are given in the sixth and final section. We wish to clarify that this is an ongoing research project with several activities such as additional base visits and interviews of contracting personnel and customers yet to be completed. Hence, this paper should be viewed more as an "interim report" rather than as a complete paper.



THIS PAGE INTENTIONALLY LEFT BLANK



II. Service Characteristics and Their Implications to Contracting

Service production differs from manufacturing in several ways. In many operations texts, the key issues that are identified include the intangibility of service output, the difficulty of portability, and complexity in the definition and measurement of services (for example, see Fitzsimmons & Fitzsimmons, 2006). To these we would also add the observation that services often involve joint production between the buyer and the supplier. These characteristics create certain differences in the production and marketing of services. For example, the joint production aspect means that the productive system is often not buffered from the customer. The customer is often present and even participating in the production process, while simultaneously being a consumer. The resulting need for "customer contact" has been analyzed in the seminal work of Chase (1981) to categorize different types of service firms and sectors. In this section, we examine the effect of some of the special characteristics of services on issues related to outsourcing of services and contracting for service delivery.

A. Characteristics of Services

There is a growing body of literature on operations management in service firms. Special characteristics of service operations are discussed in textbooks such as Sasser, Olsen and Wyckoff (1978), Murdick, Render and Russell (1990), Heskett, Sasser and Hart (1990), Lovelock (1992), Fitzsimmons and Fitzsimmons (2006), and in casebooks including Sasser, Hart and Heskett (1991).

Managing quality in service businesses, although similar in spirit to that in manufacturing, is somewhat different and is relatively more challenging due to certain inherent characteristics of service operations. These include the *intangibility of service outcome in some cases*, and the *presence and participation of customers in the creation of many services*. Intangibility of outputs results in difficulties in



matching demand and supply since such output can't be inventoried. This is, however, not meant to suggest that lack of inventory is a characteristic of services. In fact, as exemplified by a restaurant, managing inventory of supplies (termed as tangible goods by Sasser, Olsen and Wycoff (1978)) can be very critical to the success of a service enterprise.

The *diversity* of services makes it difficult to come up with generalizations that are helpful for managers of service businesses. Lovelock (1983, Summer) proposes five schemes for classifying services that offer insight for marketing and operations managers in different service businesses. Additional suggestions for managing service business are given by Lovelock (1992), Schmenner (1986, Spring), and Quinn (1992).

Chase (1981), as mentioned previously, proposed a theory of the *customer contact* approach to services which holds that the services that entail high degree of customer contact have inherently smaller potential for efficiency due to the variability and uncertainty that customers introduce in the creation of service. Apte and Mason (1995) propose that customer contact be conceptualized in two ways: first, in terms of propinquity, or a physical presence, involving a face-to-face contact between the customer and service provider, and second, in terms of a symbolic contact: the main purpose of customer contact is to exchange the information necessary in service creation and consumption. It should be noted that a service activity, in general, requires a combination of both types of customer contact. With the progress of information technology, the symbolic portion of the contact is being increasingly automated using information technology. In many cases, information technology is also being used for redefining, or reengineering, services.

Closely related to the concept of customer contact is the service characteristic of *co-production*. Not only do customers have a presence during the service-creation process, but they may have significant tasks to perform as well. Examples range from self service at gasoline stations and salad bars to the shared responsibility for communication in diagnostic services and tailored financial services



(including tax preparation). In some cases, the customer's participation in joint production is rather passive. But in other cases, such as financial planning or education, the participation may be very active and very significant in determining the quality of service production. Indeed, education is a major service sector for which an active role of the customer is absolutely critical. In the prototypical manufacturing case, customers' roles start after production has been completed. To the extent this is not the case—for example, custom production of manufactured goods with customer-provided blueprints—the manufacturing business takes on more of the character of a service.

As mentioned earlier, many services have outputs that are *intangible* and are *hard to measure* (McLaughlin & Coffey, 1990). For example, in services such as medical examinations or tax planning, output is quite intangible. Output of sales transactions involving manufactured goods can be metered rather easily with respect to the quantities involved. However, the delivered "quantity" of business consulting or medical services is rather more difficult to measure. In such cases, it is difficult for the buyer and the vendor to easily agree on exactly what output has been supplied. A serious confounding problem is that it is difficult to distinguish between the level of attributes of services and the quantity of services. For example, it may be hard to say whether medical advice is more correct, more thorough, more considerate of the patient, or simply more.

In textbook discussions of service operations, services are often described as being *complex*. A part of this complexity arises from the difficulties in measurement discussed above. A second part arises from the joint production or custom character of many services, which, in turn, has two effects: First, the presence of the customer means the service process cannot be separated from service output. The obvious consequence is a much larger set of attributes for customer evaluation. Moreover, the customer brings to the process a set of expectations, capabilities, as well as material inputs that are specific to that customer. As a result, the "output" of the process as perceived by the customer may involve many customer-specific



attributes. Participation in the production process is, in itself, a complex issue with some internal costs but possibly some consumption value as well. All these threads may be very difficult to untangle. As an example, consider a class in a management course, with the students (possibly organized into groups) and instructors interacting in the course of a case discussion. It is near impossible in practice to measure the educational output received by any one student in an objective way either in terms of quantity or attribute levels.

The special features of services lead to significant differences in the process of production, sale and consumption of services. These, in turn, have implications for market structure, pricing, and contracting for services. Karmarkar and Pitbladdo (1992) present some key features regarding service contracting that are relevant to the development of a service quality model. First and foremost, service operations are always post-contractual. Fixed-price contracts centered on output specifications can fail on two accounts. First is the difficulty of conceiving or verifying meaningful output specifications, and second is the variability of customer inputs and joint production which makes fixed-price contracts risky for the firm, even when the output specifications can be well defined. Alternatively, contracts based on process specifications, such as time and materials, can turn out to be unsuitable since these can be risky for customers. These dual risks for firms and for customers can be addressed via stage-wise or contingent contracting, in which the process is broken into stages, and the price for a given stage is made dependent on the outputs of previous stages. For example, there may be a fixed fee for a diagnosis, and a fixed fee for treatment which, however, depends on the outcome of the diagnosis. The uncertainty in customer inputs is resolved by the diagnosis before it materializes in terms of treatment cost.

B. Service Quality

Corporate experience indicates that customer satisfaction and high service quality leads to greater long-term profitability (Buzzell & Gale, 1987). The topic of service quality, therefore, has received increasing attention during the last few



decades. Deming (1985) and Crosby (1979) are notable examples of practitioner viewpoints on quality management. Gronroos' study (1982) is one of the early research papers that explicitly dealt with service quality. Adopting a customer's viewpoint, service quality is conceptualized by Parasuraman, Berry and Zeithaml (1985, Fall) as the difference between the service-quality expectations of a customer and the quality of service delivery performance as perceived by a customer. A detailed discussion of their service-quality model and the associated survey instrument, SERVQUAL, can be found in their 1990 text. Other research literature on service quality includes comprehensive collections of readings such as Bowen, Chase & Cummings (1990), Brown, Gummesson, Edvardsson & Gustavsson (1991), and Lovelock (1992). Chase and Bowen (1991) discuss service quality issues in terms of three elements of service delivery system: technology, systems and people. Apte, Karmarkar and Pitbladdo (1996) provide a new framework for measuring and improving service quality. Additionally, in discussing the measurement and management of service quality, Collier (1990) examines the issues of definitions, standards and measurement, monitoring and control of service quality.

The main conclusions of these papers are:

- Customers find it more difficult to evaluate the quality of service than the quality of goods.
- Customer evaluation of service quality involves comparison of a customer's expectations with actual service performance.
- Service quality evaluations are based on the outcome of a service as well as on the process of service delivery.

C. Service Characteristics and their Implications for Contracting

Intangibility of service outcomes makes it difficult to clearly describe and quantify services and, therefore, to contract for services. Consider, for example, the difficulty in writing a contract for an educational service involving academic lectures. How does one define a “pound of education” and how can one be sure when the



contract is fulfilled satisfactorily? As Karmarkar and Pitbladdo (1995) explain, this is the reason why in such cases we do not contract around quantities at all; rather we contract around process delivery. In general, the more information-intensive the service is, the more difficult it is to develop clear and meaningful contracts. This difficulty is somewhat reduced in services in which physical objects play a dominant role.

Intangibility of outputs also makes it *difficult to define and measure quality*. For example, even for a simple custodial service such as cleaning, it is not easy to define the desired level of cleanliness. The levels of cleaning needed for an office is certainly different than for a hospital operating room. The desired time duration for maintaining a clean status can also be an important matter in writing a contract for cleaning service. As research in service quality has found, customers typically evaluate the quality of service based on the outcome of a service as well as on the customer's experience with the process of service delivery. For example, in a dining facility, not only must the food be tasty but the manner in which the food is served must also be courteous, prompt and friendly. This means that the contracts for many services should not be based solely on outcomes but should include specifications on both the outcome and the customer's experience with the process.

Co-production requiring presence and participation of customers in the creation of many services is an important characteristic of services. For example, in an IT service such as software development, a customer's input in terms of desired specifications of a software system is critically important. For example, however competent the software developer may be, the developed software will not be satisfactory if the specifications do not accurately reflect the true needs of the customer. Hence, the contracts for services should ideally specify not only what the service provider should do but also what the customer should do. Otherwise, a satisfactory service outcome may not be realized.

Diversity of Services also makes it difficult and undesirable to use the same contract vehicles or procedures for different services. For example, given the



differences in medical services versus custodial services, it is important that the contracts for these services are customized to suit the lifecycle needs of individual services.

Finally, services are complex and may involve multi-stage processes. This makes it important, yet challenging, to write contracts that are flexible enough to cover all relevant scenarios and eventualities. Moreover, if such contract cannot be satisfactorily defined, it may be desirable to deliver certain services using internal resources as opposed to outsourcing them.



THIS PAGE INTENTIONALLY LEFT BLANK



III. Size and Structure of the DoD's Services Acquisition Environment

The DoD's procurement process is currently undergoing a transformation similar to the one experienced by private enterprises. This transformation is changing how the agency manages its procurement function, including its people, processes, practices, and policies. The DoD's procurement function is currently transforming from a transaction-oriented perspective to a strategic-oriented organization. No longer viewed as a tactical, clerical, or administrative function, the procurement function is gaining enhanced status as leading organizations understand its importance in achieving strategic objectives and its impact on competitive advantage. Specifically, the procurement transformation is taking place in three major areas: "moving from buying goods to buying services, moving from a command and control relationship to a partnering relationship between the government and contractors, and moving from a paper-based procurement system to electronic procurement" (Abramson & Harris, 2003). This research paper focuses primarily on the first transformation area: services acquisition.

The transformation from buying goods to buying services is considered the driving force behind the procurement revolution. Gansler describes this transformation as a reflection of the changing role of the government from that of a "provider of goods" to that of a "manager of the providers of good and service" (2003). In addition, the method of procuring services is also changing. Traditionally, through the Request for Proposal (RFP), the government would dictate what the contractor was to do and how to do it. Through the use of detailed specifications and requirements, the contractor was directed how to perform the contracted effort. The procurement transformation is changing how the RFP is being developed. RFPs are now being written to communicate the performance objectives or end-results of what the contracted effort needs to achieve, not how the work is to be done (Denhardt, 2003).



These two driving forces, the change in what the government is buying (services) and how the government is buying (performance-based contracts), is resulting in the government procuring solutions and knowledge, as opposed to specific supplies or standardized services (2003).

A. Growth and Scope of DoD Service Contracts

The federal government is the largest purchaser in the world: every 20 seconds of each business day the federal government awards a contract with an average value of \$465,000 (Stanberry, 2001). In Fiscal Year 2004, federal government procurement spending totaled approximately \$328 billion. Of that amount, approximately \$99 billion was spent by the civilian agencies, with the remaining \$228 billion spent by the Department of Defense (Federal Procurement Data System, 2004). Furthermore, the Department of Defense is the federal government's largest purchaser of services. As illustrated in Figure 1, since FY 1999, the DoD's spending on services has increased by 66%, to over \$118 billion in FY 2003—approximately 57% of total procurement value.

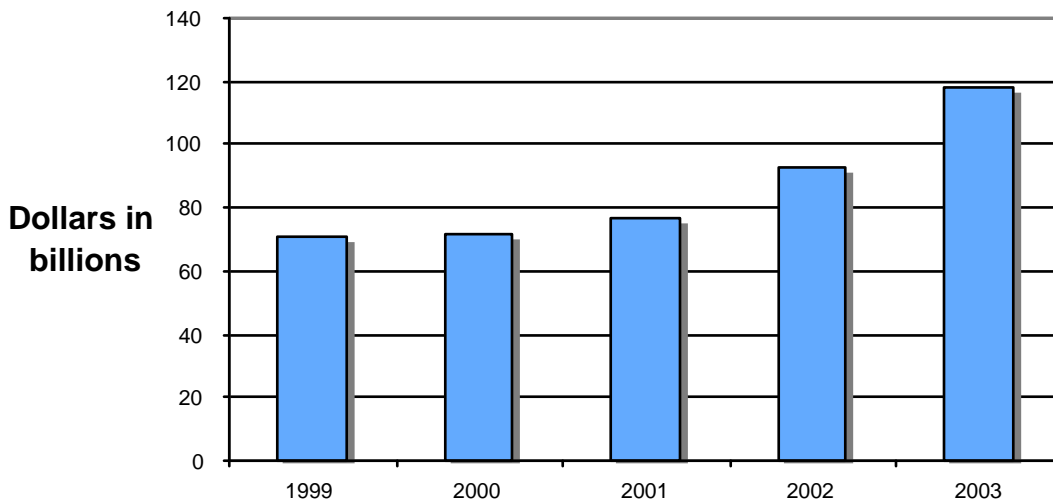

Figure 1. DoD Spending on Services
(GAO, 2005a)



Compared to other contract categories, the expenditure in services is the largest single spend category in the Federal Government. Figure 2 reflects the growth of services contracts in relation to the other contract categories. Between FY 1990 and 2000, procurement for services grew from \$70 billion to \$87 billion, yet the procurement of supplies and equipment decreased from \$102 billion to \$77 billion in that same time frame.

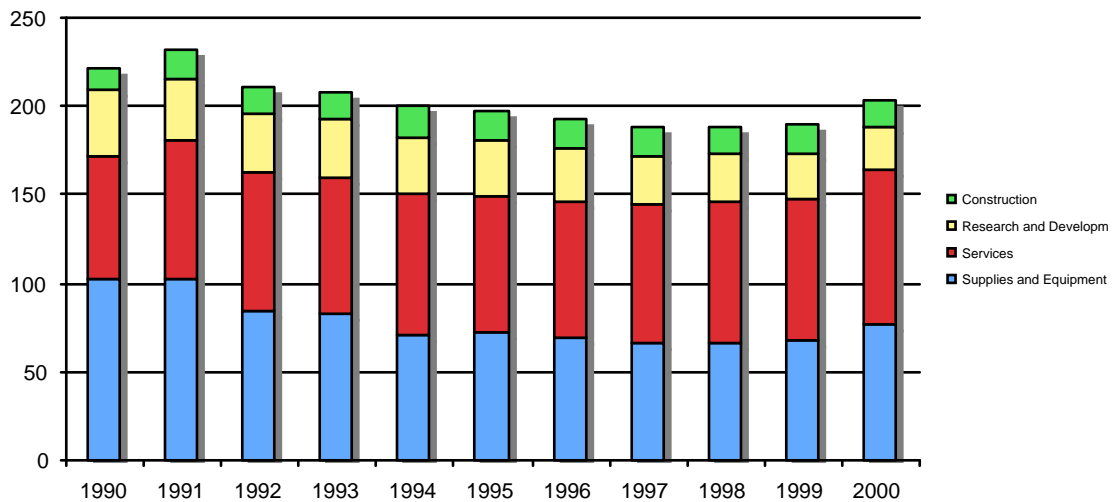

Figure 2. Federal Contract Spending
(GAO, 2001b)

Moreover, Figure 3 compares the procurement of services with the procurement of goods during the period between FY 1998 and FY 2002 in the Department of Defense.



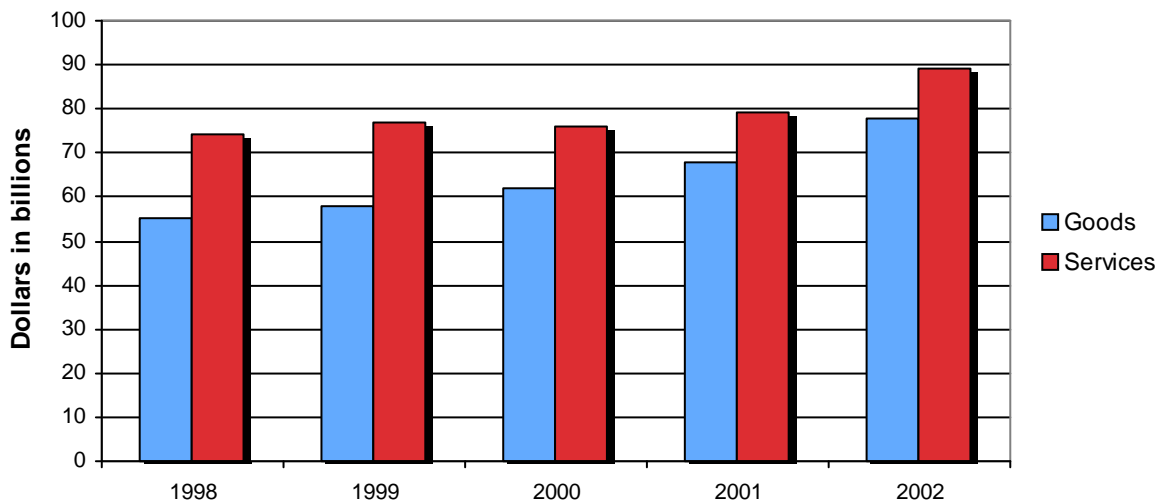

Figure 3. The DoD's Contracts for Goods and Services
(GAO, 2003b)

The DoD procures a variety of services in support of its mission. These services range from traditional commercial contracts such as IT support, custodial services, and grounds maintenance, to mission-related services such as aircraft and engine maintenance, and initial pilot training. Figure 4 shows the major categories of services procured by the DoD and their values; we see that Professional, Administrative, and Management Support, and Construction, Repair and Maintenance of Structure and Facilities are the types of services most often procured by the Department of Defense.



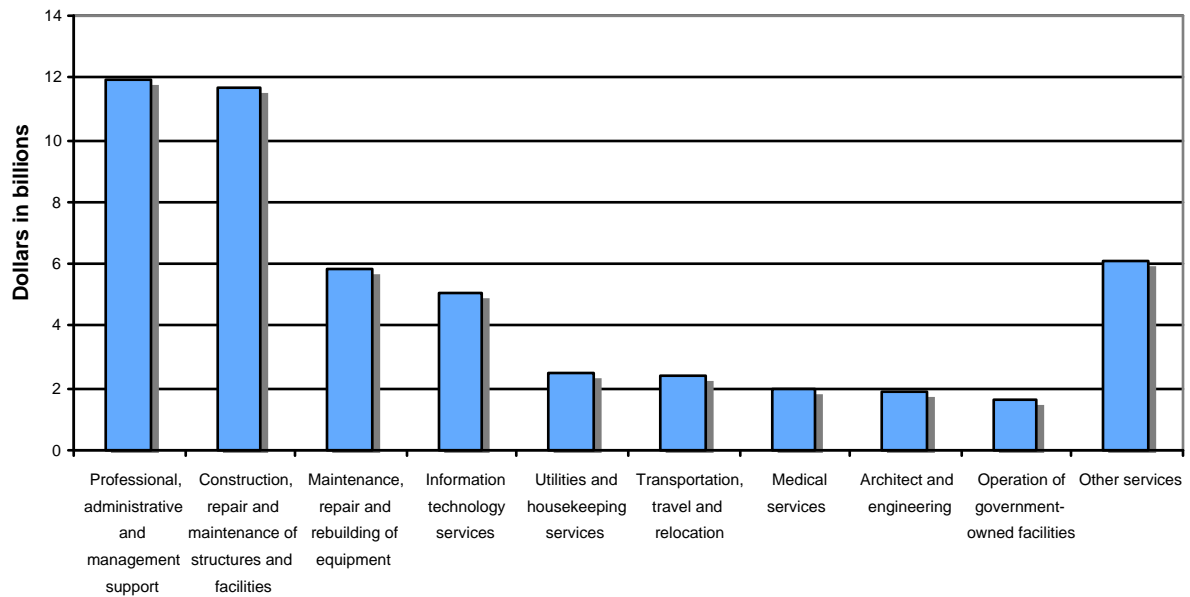

Figure 4. Services Purchased by the DoD in FY 2000
(GAO, 2002a)

We identified specific examples of these various services during recent visits at military installations in the central and northern California area. For example, at the Presidio of Monterey, an Army installation providing support services to the Defense Language Institute and the Ord Military Community, the Army contracts for base operations support, grounds maintenance, custodial services, and dining facilities services, among other contracts (Auernig, 2006).

At Travis Air Force Base, a major Air Mobility Command (AMC) base, these same types of services are procured, as well as several mission-unique services such as transient alert services for the flight-line operations, passenger screening for the airfield passenger terminal, and falconry services in support of the Bird Aircraft Strike Hazard (BASH) program. In addition, Travis AFB also provides contracting support to the David Grant USAF Medical Center. In this capacity, Travis AFB procures various medical services such as medical transcription, nurse services, blood testing, registered nurse staffing, and medical coding services (US Air Force, 2006).



B. Services Contract Management—an Overview

The management of the DoD's services contracts typically follows the traditional contract-management process. This contracting process consists of the following phases: procurement planning, solicitation planning, solicitation, source selection, contract administration, and contract closeout as illustrated in Figure 5 (Garrett & Redon, 2005). Each of these contracting phases will be discussed, along with key practice activities.

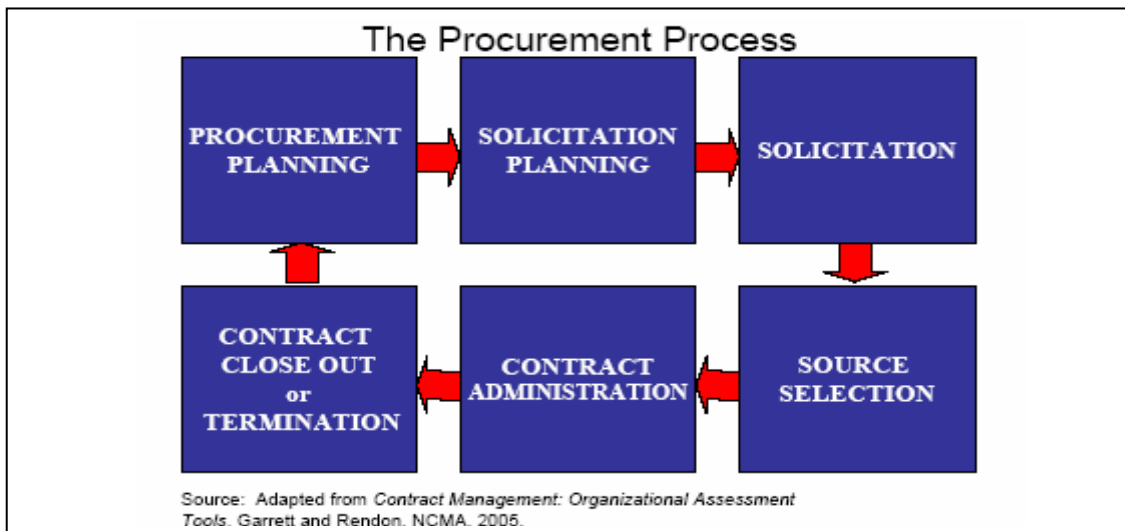

Figure 5. The Procurement Process

Procurement planning is the first contracting phase and involves identifying which business needs can be best met by procuring products or services outside the organization. This process involves determining whether to procure, how to procure, what to procure, how much to procure, and when to procure. Key practice activities included within the procurement planning phase include determining the initial scope of work or the description of the product in the acquisition, conducting market research to analyze the level of technologies and types of products and services available in the marketplace, determining funds availability, and developing initial cost and schedule estimates as well as manpower resources. Developing an initial Statement of Work (SOW) and Work Breakdown Structure (WBS) are also included in the procurement planning phase. Conducting an initial integrated assessment of



contract-type selection, risk management, and an initial analysis of potential contract terms and conditions is also part of the procurement planning process (Garrett & Redon, 2005). It should be noted that many of the contractual documents developed in the procurement planning phase are initial draft documents, such as SOWs, WBSs, project scope statements, and funding and manpower estimates. These are initial draft documents simply because they are typically modified and revised as the acquisition program office becomes more knowledgeable of the business and technical aspects of the program. Industry business and technical knowledge are typically acquired through the use of market research activities, industry conferences, and Requests for Information (RFIs).

The second phase of the procurement process is **solicitation planning**, which involves the process of preparing the solicitation documents needed to support the acquisition. This is a critical phase of the procurement process since it is during this phase that the work statements, specifications and other exhibits, standard terms and conditions, as well as special contract requirements are developed, revised, and finalized. Key practice activities within the solicitation planning process include using standard procurement forms and documents such as solicitation templates, model contracts, specifications and item descriptions, solicitation provisions, and contract terms and conditions (2005).

Solicitation is the third phase of the procurement process and is the process of obtaining bids and proposals from prospective sellers on how to meet the objectives of the project. The solicitation phase is critical to the overall acquisition strategy because it is this phase that executes the procurement planning strategy for a full and open competition or sole-source procurement. Some key practice activities within the Solicitation phase include conducting market research and advertising to identify new sources of supplies and services for the purpose of developing a list of interested offerors (Garrett & Redon, 2005). These offerors will receive the solicitation requesting the proposal. Another key practice activity in the Solicitation phase includes conducting a pre-solicitation or pre-proposal conference



to ensure that all prospective contractors have a clear, common understanding of the technical and contractual requirements of the acquisition (2005).

Source selection is the fourth phase of the contracting process and involves receiving proposals and applying evaluation criteria to select the contractor. Key practice activities within the source-selection process include using evaluation criteria focusing on management, technical, and cost, tailoring the basis for award to either lowest cost/technically acceptable or best value. In evaluating proposals, the Program Manager must also take into consideration an offeror's past performance (2005).

Contract administration is the fifth phase of the contracting process and entails managing the relationship with the contractor and ensuring that each party's performance meets the contract requirements. During contract administration, the government's focus is on managing the contractor's cost, schedule, and performance. Key practice activities within the contract administration process include using an integrated team approach for monitoring the contractor's cost, schedule, and performance, and having an established process for administering incentive and award-fee provisions (2005). These incentives and award fees are tools used to motivate the contractor to meet specific performance standards.

The *Federal Acquisition Regulation (FAR)* identifies two major contract categories: cost reimbursement contracts and fixed-price contracts, depending on the method of compensation due to the contractor. In the fixed-price category, the contractor agrees to provide specified supplies or services in return for a specified price, either a lump sum or a unit price. The price is fixed and is not subject to change regardless of the contractor's actual cost experience. Only if the contract is modified is the price subject to change (Garrett & Redon, 2005). There are various types of fixed-priced contracts such as Firm Fixed Price (FFP), Fixed Price with Economic Price Adjustment (FP-EPA), and Fixed Priced Incentive (FPI). In the cost-reimbursement contract category, the contractor agrees to provide a best effort in performing the requirements of the contract, which is typically described based on



broad specifications. In return, the contractor is reimbursed for all allowable costs up to the amount specified in the contract. Among cost reimbursement contracts we find Cost Sharing (CS), Cost Plus Fixed Fee, (CPFF), Cost Plus Incentive Fee (CPIF), and Cost Plus Award Fee (CPAF).

The final phase of the contracting process is **contract closeout**, the process of verifying that all administrative matters are concluded on a physically complete contract. This involves accepting final deliveries, making final payment to the contractor, as well as completing and settling the contract and resolving any open items. Key practice activities within the contract closeout phase include using checklists and forms for ensuring proper documentation of closed contracts and maintaining a “lessons learned and best practices” database for use in future contracts and projects (2005). An important aspect of closing out the contract is conducting a final evaluation of the contractor’s performance in terms of meeting cost, schedule, and performance objectives. This final contractor evaluation will be used in future contract competitions and source selections. The contract closeout phase is often forgotten and has been considered an administrative burden or relegated to a clerical or non-essential task.



THIS PAGE INTENTIONALLY LEFT BLANK



IV. DoD Policy on Contracting for Services

Since the beginning of the 1990s, the DoD has seen a steady growth in the volume, complexity and value of service contracts. Some of this growth results from an increase in the level of operations, some of it from the replacement of the civilian workforce by contractors, and some is a result of government policy dictating maximum use of contractors.

Compared with other federal agencies, the Department of Defense is often viewed as being particularly aggressive in complying with the Office of Management and Budget's *Circular A-76, Performance of Commercial Activities*. The Circular directs that the "longstanding policy of the federal government has been to rely on the private sector for needed commercial activities." A commercial activity is defined as, "a recurring service that could be performed by the private sector and is resourced, performed, and controlled by the [government] agency through performance by government personnel, a contract, or a fee-for-service agreement" (OMB, 2003).

Accompanying this growth in outsourcing activity has been a downsizing of the DoD civilian and military acquisition workforce, which is responsible for administering these contracts. Also, Congress has mandated a shift to Performance-based Service Acquisition (PBSA). PBSA is intended to obtain higher levels of contractor performance at lower cost, and promote a partnership-oriented, long-term approach that allows the government—and the DoD in particular—to benefit from commercial best practices (US Air Force, 2005; DoD Office of Inspector General, 2003; Federal Acquisition Council, 2006).

It is of interest that *Circular A-76* mandates that, while actual performance of an activity may be outsourced, control remains with the government agency no matter what decision is ultimately made as a result of a competition between in-house and commercial providers.



The complexity of the monitoring process and the nature of the services outsourced make this contradiction even more difficult to live with. A sanguine, yet now somewhat dated view of agencies' overall management challenges, has been provided by the DoD Inspector General:

The seven audit reports that I am bringing to your attention today have a common theme, which is that eleven years of workforce downsizing, without proportionate workload reductions or productivity increases, have created or exacerbated mission performance problems across a wide spectrum of DoD organizations and civilian personnel specialties. In an age when organizational agility is the watchword for successful businesses, DoD has been anything but agile, when it comes to managing human capital. This is partially due to restrictive personnel management laws and regulations, but also to previous reluctance to innovate and lack of strategic planning regarding the civilian workforce. (2001)

In transaction cost analysis (Williamson, 1983), a distinction is made between the cost of delivering the service ("production" costs) and the cost of managing the relationship between the buyer and seller ("transaction" costs). *Circular A-76* directs a decision based entirely on production costs while remaining silent on transaction costs. Yet, from the point of view of both the taxpayer and the mission, the total cost should perhaps be the deciding factor.

The issue of "control" (also referred as a synonym to "oversight" or "surveillance") transcends that of cost. The government agency that has outsourced the activity may simply not have access to the necessary personnel or budget to adequately exercise this control. Williamson emphasizes that, traditionally, a hierarchical (in-house) arrangement has lower transaction costs because it is easier to direct one's own employee to perform an activity. In contrast, specialist firms may have lower production costs because of experience or some type of economies of scale. The challenge for government is to equitably consider all these factors when making a sourcing decision.



A. The Challenge of Outsourcing Services

Traditionally, DoD contracting practice has been focused on goods, not services. This is in spite of the fact that services now account to over 55% of the dollar volume of DoD contracts (DoD Office of the Inspector General, 2005). A similar trend has been observed in other federal agencies (GAO, 2005c). Congress has mandated, through the *National Defense Authorization Act of 2002*, an improved management of the service contracting process (GAO, 2005a).

Outsourcing services on a large scale poses unique challenges for the DoD. The Department's employees, both those officially part of the "acquisition workforce" and those otherwise involved in the services acquisition process, are the focal point of any effort to increase the quantity and quality of outsourcing. Yet at the same time, the numbers of those employees have been falling rapidly; it is not unreasonable to claim that, in many cases, the necessary numbers of staff or skills are not present to ensure the adequate monitoring of the increased scale.

The DoD has a responsibility to act as a "knowledgeable client" for the nation in its relationship with the private sector. As a knowledgeable client, its employees must be in a position to maintain a number of capabilities, including the following:

1. An understanding of what services may or should be outsourced,
2. An awareness of the capabilities and limitations of private-sector firms in the appropriate area,
3. The ability to tender for and competently evaluate competing bids from both private-sector firms,
4. Where a service currently provided in-house is being considered for outsourcing, the ability to evaluate competing bids from in-house and private sources according to the complex requirements set by the Office of Management and Budget, and
5. The ongoing ability to develop, maintain, and improve the surveillance of contracted activity to ensure that value is being obtained, and to take corrective action where required. (OMB, 2003; GAO, 2005a)



All of the above require an appropriate number of skilled personnel in a wide variety of fields. Expertise is needed in both contracting per se and in the technical or functional area that is being outsourced. Where outsourcing is viewed as a way to reduce government headcount (particularly that of civilian personnel), those remaining in the job need to have higher levels of expertise to carry out adequate surveillance of each contracted activity. The GAO has emphasized the importance of improvements in monitoring (or “surveillance”) of DoD service contracts:

According to DOD officials, insufficient surveillance occurred because surveillance is not as important to contracting officials as awarding contracts and therefore, does not receive the priority needed to ensure that surveillance occurs. [...] Further, surveillance was usually a part-time responsibility and some personnel felt that they did not have enough time in a normal workday to perform their surveillance duties. (GAO, 2005a)

Another GAO study concurs with the above. It explains:

Addressing human capital issues in acquisition is not just a matter of the size of the workforce. It is also a capacity issue. While acquisition reforms have helped streamline smaller acquisitions, larger acquisitions, particularly for information technology, remain complex and technical. Yet agencies are at risk of not having enough of the right people with the right skills to manage these procurements. Consequently, a critical issue the federal government faces is whether it has today, or will have tomorrow, the ability to manage the procurement of increasingly sophisticated services. (GAO, 2001a)

That such phenomena should occur is perhaps a natural outcome of the contradictory forces at work in outsourcing activities. While the emphasis is on reducing in-house personnel, outsourcing in itself may require a targeted increase in the number of government employees, as well as some change in their qualifications, to ensure that outsourcing is carried out according to regulations in a cost-effective, “best value” manner.

The Air Force represents an example of an effective approach to the need for up-front planning of the in-house personnel requirements associated with outsourcing, as well as the inherently interdisciplinary mix of government personnel needed for adequate contract surveillance (US Air Force, 2005). However, the Air



Force experience illustrates the difficulties of considering potential or actual contract management costs as part of the outsourcing decision.

A RAND study of 22 PBSA-inspired contracts at 15 Air Force bases concluded that information on the internal costs of outsourcing was “highly impressionistic” and that data on quality assurance costs, which should theoretically decline with a switch to PBSA, were ambiguous (Ausink, Camm & Cannon, 2001). Even the actual expenditures on contracts were difficult to calculate and evaluate within the agency:

DOD is in the early stages of a spend analysis pilot. Although DOD is moving in the right direction, it has not yet adopted best practices to the same extent as the companies we studied. Whether DOD can adopt these practices depends on its ability to make long-term changes necessary to implement a more strategic approach to contracting. DOD also cites a number of challenges, such as its large and complex need for a range of services, the fragmentation of spending data across multiple information systems, and contracting goals for small businesses that may constrain its ability to consolidate smaller requirements into larger contracts. Challenges such as these are difficult and deep-rooted, but companies also faced them. For DOD to change management practices for the contracting of services will require sustained executive leadership at DOD as well as the involvement and support of Congress. (GAO, 2003a)

Given the difficulties of capturing costs at many levels and for different activities, it is perhaps not surprising that the DoD also suffers from major challenges in personnel management.

B. The “Human Capital” Issue

It is somewhat ironic, but not at all unexpected, that the downsizing of the DoD civilian workforce, and the increasing emphasis on moving military personnel into deployable positions, has resulted in increased concerns about who is minding the store. In its government-wide review of the acquisition function, the GAO emphasizes “human capital” as a “cornerstone” for an effective acquisition function—in particular, “Valuing and Investing in the Acquisition Workforce.” Also,



“Integration and Alignment” should form part of “Strategic Human Capital Planning” (GAO, 2005c).

The emphasis on “Integration and Alignment” is particularly salient for the DoD. What is being implied is that the in-house workforce needs to be developed and maintained in a manner commensurate with the workload requirements created by outsourcing. In an analysis of the Air Force’s PBSA activities based on commercial practices for outsourcing of installation management, RAND noted that government personnel should have the ability to:

- describe what service is desired and not how to perform the work,
- use measurable performance standards and quality assurance plans,
- specify procedures for reductions in fee or price when services do not meet contract requirements, and
- include performance incentives where appropriate. (Baldwin & Hunter, 2004)

Yet Baldwin and Hunter also emphasize in the same report the need for more sophisticated statements of requirement, refinement and reduction of performance metrics, and, notably, widespread participation in the services contracting process. Such participation necessarily requires time and the application of expertise by qualified people. Particularly in an era of downsizing and with an aging workforce, recruiting and retaining suitable civil service personnel is a difficult process. Meanwhile, the military services must “grow their own” personnel in a closed environment that usually begins at the recruiting station and balance a complex mix of occupational specialties, ranks, and attrition rates with the added complication of deployments that are impossible to forecast.

The *FAR* and other contracting regulations impose a host of responsibilities, such as those discussed above, on acquisition and other government personnel for the entire service’s contracting lifecycle. Not only must the agency head ensure that these responsibilities are carried out, but “best practices” must be used (Federal



Acquisition Council, 2006). However, the policy-making agencies responsible for contracting rules have little connection to the organizations who set budgets or who assign qualified people to the positions required to develop or monitor the contracts that result from those contracting rules.

In the private sector, this lack of communication may be less of a barrier, given the common sense of purpose imposed by the pursuit of profit (Balwin & Hunter, 2004). However, it is reasonable to state that increased contracting and decreased surveillance could lead to reduced quality performance. Some of the more extreme examples of this divergence in direction that have already led to widespread media attention include insufficient monitoring of contracts in Iraq by the DoD, the Department of State, and other federal agencies (GAO, 2006) and the employment of illegal immigrants by contractors at military installations (Witte, 2005, October 29).

The Department of Defense has responded to some of this divergence in policy by attempting to supplement or substitute on-site human expertise using a variety of methods. The first is to centralize, either on a national or regional basis, expertise in contracting or in a functional area, taking some responsibilities (and positions) away from individual installations. For example, the Army Contracting Agency and Army Installations Agency have been established as “centers of excellence” to direct and assist with the provision of the appropriate services.

The Department of the Navy has placed all shore installation-management activities under regional commanders (such as Commander Naval Region Southwest) who then may establish detachments, as tenant activities, at specific installations as the perceived need may justify. Contracting itself has also been centralized in the Navy; for example, all contracts above the “simplified acquisition threshold” (usually meaning small purchases such as office supplies which are carried out locally using credit cards) are done by the Fleet and Industrial Supply Center (FISC) for that region. For example, the FISC in San Diego serves all Navy and Marine Corps installations in California and Nevada.



Another method used by the DoD is to “virtualize” expertise by creating Web-based sites where published direction, documents such as “lessons learned” can be posted, or chat rooms can be hosted. There are now a variety of such facilities in place. While these initiatives may appear laudable, questions remain. Centralization and regionalization are convenient vehicles for budget cuts, with the side effect of removing financial management flexibility from installation commanders. The authors did note, however, that the Air Force seems to be resisting this trend and that Wing Commanders at installations are retaining a traditionally broad range of responsibilities, personnel and budget under their chain of command.

Notice that many types of services, and their contracts, do not lend themselves to codification or to asynchronous communication. In such circumstances, the richness of face-to-face communication and the leveraging of experience acquired by long-serving government personnel can be diminished or lost if human capital is not carefully managed. According to Nonaka and Takeuchi (1995),

frequent dialogue and communication helps create a “common cognitive ground” among employees and thus facilitates the transfer of tacit knowledge. Since members of the organization share overlapping information, they can sense what others are struggling to articulate.

The shift from explicit, clerical-like functions to complex activities requiring a much more significant component of judgment is well represented by two shifts: one being that the majority of DoD acquisition is now in services rather than goods, and the second being the emphasis on PBSA. For example, the Air Force established a goal that at least half of all service acquisitions should be performance-based by 2005 (Baldwin & Hunter, 2004). Rendon (2005, Summer) has also commented that what was previously viewed simply as “purchasing” within the DoD has now evolved into a complex process that includes integrated supplier management, consideration of total ownership costs, cross-functional teams, and strategic sourcing strategies.



Yet a RAND study of the Army showed that the remaining civilian acquisition personnel were not being used “as effectively as they should be,” even with the recent loss of many military acquisition personnel to deployments (Hanks, C.H., Axelband, E.I., Lindsay, S., Malik, M.R., & Steele, B.D. 2005). The shift toward PBSA has significant implications for the government’s in-house capabilities to perform outsourcing, but how these implications will be dealt with remains an interesting area for further research.

In its comprehensive review of the federal government’s outsourcing process, the Commercial Activities Panel, a congressionally chartered body chaired by the head of the GAO, emphasized that outsourcing policy be “consistent with human capital practices designed to attract, motivate, retain, and reward a high performing federal workforce.” Similarly, the Panel concluded, “the government faces continued and significant management, human resource, and professional development challenges, which affect the government’s ability to manage the cost, schedule, and performance of in-house and contracted activities” (GAO, 2002b). A significant increase in the volume, cost and complexity of outsourced activity, declining numbers of experienced personnel, increased deployments, and widely rumored budget cuts do not point to a simple resolution of the challenges of contracting for services within the DoD.

It is difficult in the best of times to undertake horizontal coordination between or within different agencies in Washington and translate them into improved cost-effectiveness in the field. Yet the integration of strategic human planning with other functions has been identified as critical to achieving desired mission outcomes (GAO, 2005d; 2005e). The DoD must also remain an attractive customer for the best-performing businesses, and remain a “knowledgeable client” so it can continue to act as an effective steward of public funds. PBSA, in the words of a RAND study, requires the DoD to develop a “better understanding of how commercial firms do things” (Ausink, Camm & Cannon, 2001). Given the emerging environment, maintaining an effective capability within the DoD to determine if and how services



should be delivered, and how such services should be overseen, may pose a significant challenge.



V. Site Visits

As part of this research, we visited two bases to collect information about their respective service acquisition processes: the Presidio of Monterey (POM) and Travis Air Force Base. We visited their facilities, interviewed their contracting officers and spoke with several among their contract customers. Our impressions follow.

A. Presidio of Monterey

The Presidio of Monterey has a complex history. Originally established as a fort (the Spanish meaning of “presidio”) under Spanish rule in 1770, POM began its life under the US flag as a garrison for Marines in 1846. The site was inactive from 1856 until 1902, and hosted a variety of Army units until its official closure in 1944. Military training in the Monterey area continued five miles north of the city at Fort Ord (established 1917)—at 28,000 acres one of the largest Army bases ever established. Fort Ord operated as a basic and advanced combat training center and until its closure under the Base Realignment and Closure (BRAC) process in 1994. After 1994, the POM continued to operate on its original 392 acres, which currently includes 180 buildings (Uslar, 2005). While language training in Japanese began in secrecy at the dormant POM beginning a few months before the attack on Pearl Harbor, in 1946 the site was officially reactivated as a foreign language training center, now known as the Defense Language Institute Foreign Language Center (DLIFLC or informally DLI). While DLI is part of the Army’s Training and Doctrine Command (TRADOC), it has always had the mission of training military personnel from all of the military services. Additionally, a small number of civil servants from the DoD and other federal agencies learn foreign languages at DLI, which graduates over 3,000 students annually in about 25 languages. While TRADOC is responsible for the funding and management of DLI, the functional sponsor is the Office of the Secretary of Defense (OSD).



When Fort Ord closed in 1994, the Army began transferring segments of the base to a variety of entities. A small portion of Fort Ord was retained for military use and designated as Ord Military Community (OMC). OMC includes DoD offices, housing, community facilities, and notably some POM and DLI organizations that could no longer be accommodated on the original POM site, given the growth of DLI. Some support, such as transportation and recreation, is also provided by POM to other DoD installations in the Monterey area. In a reversal of roles since the 1994 BRAC action, OMC is now a “tenant activity” of POM, which provides all administrative support such as contracting (DLIFLC, 2006; Department of Toxic Substances Control, 2006; Presidio of Monterey, 2006).

Since the closure of Fort Ord, the end of the Cold War and the attacks of September 11, 2001, DLI has both changed its mission and begun to grow rapidly. The focus has changed from the languages of the Warsaw Pact to those of the Middle East and Asia. In January 2006, DLI received additional funding of \$362 million from OSD to further enhance the quantity and quality of instruction of over 200 classrooms and offices. This includes reducing average class size, hiring over 300 additional language instructors above the current complement of approximately 900, as well as adding about 250 additional support staff. A great deal of construction is also planned, extending until approximately 2012. POM, whose physical facilities have developed in the haphazard manner so typical of military bases, will evolve into a more campus-like facility designed around DLI’s mission. Given the current expansion of POM and DLIFLC activity levels, a key challenge for both organizations will be agreeing on common levels of support and coordinating mission expansion and physical space requirements (Cairns, 2005, December 1; Howe, 2006, January 22).

1. Contracting Organization

Contracting for DLI and other activities supported by POM is provided by the Directorate of Contracting (DC), which falls under the POM Garrison Commander. Previously located on the POM proper, the DC’s offices relocated in early 2006 to



the DoD Center, a large building at OMC, which served as the medical center for the previous Fort Ord. The DC is also functionally part of the Army Contracting Agency Southern Region (ACASR), headquartered at Fort Sam Houston in San Antonio, Texas. DLI is the largest single entity supported by the DC; its needs tend to directly or indirectly influence the remainder of the contracting activity carried out by the DC.

Furthermore, although DLI is the responsibility of TRADOC, POM and its associated physical infrastructure (land, roads, buildings, and utilities) is the responsibility of the Army's Installation Management Agency (IMA) Southwest Region, also headquartered at Fort Sam Houston. POM is also responsible for management of two training facilities: Fort Hunter Liggett and Camp Roberts, both located about 80 miles southeast of Monterey near Paso Robles.

Accordingly, the DC has a number of reporting relationships within the DoD, in addition to dealing with private bidders and contractors. Each of these relationships encompasses a specific mission, budgetary allocation, and regulatory framework. Additionally, the funding and activity levels may not necessarily be coordinated. The GAO has commented that among the services, the Army appears to have the greatest problem maintaining adequate levels of Base Operating Support (BOS) funding, which can potentially contribute "to the degradation of many installation facilities and can adversely affect the quality of life and morale of military personnel" (2005b).

The above situation represents a challenge: the base's mission (in this case, particularly language training) is growing rapidly but, for example, the IMA or ACA is not in a position to fund the additional contracting workload associated with that growth. We discussed the challenges imposed by centralization of functional responsibilities within the different services previously. In the case of POM, the GAO's views on the subject may be particularly pertinent:

Because the military services have often based future requirements estimates largely on prior expenditures, they do not necessarily know if BOS services were provided at appropriate levels. DOD and the military services have a



strategic plan for installations and have multiple actions under way to address these problems, but they have not synchronized varying time frames for accomplishing related tasks. Until these problems are resolved, DOD will not have the management and oversight framework in place for identifying total BOS requirements, providing Congress with a clear basis for making funding decisions, and ensuring adequate delivery of services.

While the Army's and Navy's creation of centralized installation management agencies can potentially create efficiencies and improve the management of the facilities through streamlining and consolidation, implementation of these plans has so far met with mixed results in quality and level of support provided to activities and installations. Until more experience yields perspective on their efforts to address the issues identified in this report, GAO is not in a position to determine whether the approach should be adopted by the other services. (2005b)

One unique characteristic of the DC is its relationship with the two nearby cities of Monterey and Seaside. It should be added that the legislation providing for the closure of Fort Ord in 1994 provided for a "demonstration project" (made permanent in 2003) that gave privileged contractor status, on a no-fee, cost-reimbursement basis, to the Presidio Municipal Services Agency (PMSA) [originally known as the Joint Powers Authority (JPA)]. The PMSA is an inter-municipal consortium of the cities of Monterey and Seaside. The first JPA contract was signed in 1997, and the current agreement under the PMSA has been described as follows:

Under the expanded contract, which was signed in May 1999, the JPA maintains about 120 buildings at DLIFLC & POM and 35 buildings at the Annex. The buildings include such facilities as shopping malls, churches, a movie theatre, libraries, barracks, clubs, a sports center, and administrative buildings. As part of the contract, the building maintenance crews from the City of Monterey operate from facilities and shops at DLIFLC & POM, ensuring that support and services is immediately available.

Competing against national, commercial businesses, the City of Monterey was again awarded the contract through a competitive bid process in 2001. The contract is priced at \$18 million over a 5-year period. Fire services are now contracted separately [...] and sewer maintenance is no longer part of the contract, as the City purchased the sewer system in July 2002.

Through this partnership and contract, the Army has realized a 41% reduction in expenses when compared with previous base operation costs and private contracts. The City has also worked with the military staff to reduce energy



costs, by installing photocell timers and HVAC controllers. Some \$60,000 in energy costs alone have been saved annually for one building. (DLIFLC, 2006)

In 2000, the Army Audit Agency concluded that the use of PMSA had resulted in a 41% cost reduction compared to previous military and private services providers. POM has explained that “the local municipalities have built-in incentives to reduce costs, improve techniques, and streamline procedures as they are using their resources up front until they are reimbursed” and that Monterey and Seaside are “non-profit agencies with reasonable general and administrative costs” with the necessary technical expertise in areas such as traffic engineering (2004, January 24).

During the 2005 BRAC hearings, the “Monterey model” was cited as an example of a technique for reducing BOS costs, and a number of adjoining communities proposed similar arrangements could be put in place to preserve their military installations. It is of interest that the PMSA uses the services of both cities’ municipal workforces and also contracts with the private sector to carry out work on the POM and OMC sites. Routine maintenance carried out by PMSA for the Army currently costs approximately \$5.3 million in Fiscal Year 2004-2005 (Cairns, 2005, December 1). The service supply chain model of the contracting arrangements at POM is shown in Figure 6.



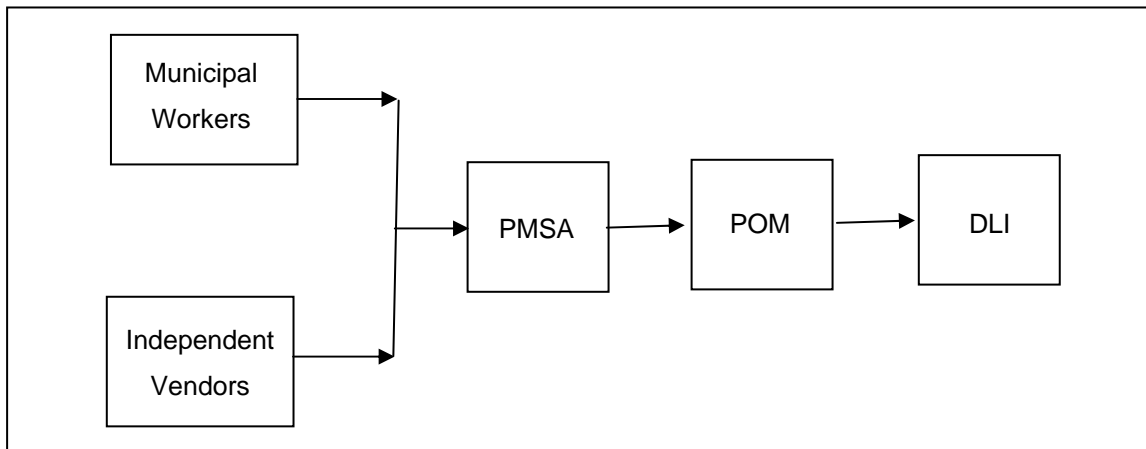

Figure 6. Service Supply Chain at POM

2. Contracting Activities

The DC is responsible for managing 53 contracts involving approximately 500 contracting actions (such as new contracts, renewals and amendments) annually, representing a total value of approximately \$35 million—including \$5.3 million contracted with PMSA (Cairns, 2005, December 1). However, as described above, the creation of IMA and ACA have had a significant impact on the DC’s staff, which has declined from 80 to 12. Additionally, funding is often inadequate to cover contracts in force, and often is allocated by IMA or ACA on an incremental (less than yearly) basis

Major contracts managed by the DC during FY2006 included grounds and other infrastructure maintenance (mainly through the PMSA), supply of gas and electricity, custodial (janitorial) services, food services (which use contractor personnel in two POM dining halls), maintenance and dispatching of the motor pool (including buses), audio visual and IT services in support of the instructional mission, and fire protection for the POM from the City of Monterey, which is not covered by the PMSA.

For each contract, monitoring of contractor performance is the responsibility of the POM, DLI or other organization that benefits from the contractor’s services. For example, custodial services are monitored and the contractor performance



reported to the DC by government employees within the Directorate of Public Works. These personnel are known by various titles such as “technical personnel” or “quality assurance evaluators.”

Efforts are underway to improve and standardize the training of these staff members so they can carry out their duties in a consistent manner and ensure that the DC has the proper information on contractor performance in exercising its oversight responsibilities on behalf of the government. These initiatives are particularly important given the shortage of contracting staff. A related initiative by the DC to deal with the staffing problem is to reduce the total number of contracts through consolidation, which has a major impact on the administrative workload of both DC and user-organization personnel.

We found POM staff to be highly conscious of their role in supporting the mission, notably DLI’s rapidly expanding instructional activities. However, there is concern about the long-term ability of POM to provide an acceptable level of service to DLI given the significant staff reduction. The problems can be deceptively subtle. For example, we mentioned previously that DLI has received significant funding from the OSD to improve the quality of instruction and the production of qualified linguists. However, much of the supporting infrastructure for this initiative will be provided through contracts. Requirements determination, market research, tendering, evaluation of proposals, correspondence with bidders, bid evaluation, contract award, and contract monitoring all require a variety of qualified personnel who may not currently be available. Additionally, agencies such as IMA, ACA or TRADOC may view DLI’s expansion as an OSD-directed initiative that does not necessarily commit those organizations to assisting POM.

B. Travis Air Force Base

Travis Air Force Base is located approximately 50 miles northeast of San Francisco. Travis can be considered a small city unto itself, complete with airport, hospital, restaurants, and neighborhoods. As an Air Mobility Command (AMC)



Base, Travis is home to the 60th Air Mobility Wing (AMW), which is the largest air mobility organization in the Air Force. Flying the Lockheed C-5 Galaxy cargo aircraft and the KC-10 Extender tanker aircraft, the 60th AMW fulfills its mission of Global Reach and flying support and humanitarian airlift missions anywhere in the world. Travis is also home to the David Grant Medical Center, the second largest medical treatment facility in the Air Force.

1. Contracting Support

Providing contracting support to Travis Air Force Base is the mission of the 60th Contract Squadron (CONS). The 60th CONS awards and administers over \$320 million annually in contracts for construction, supplies, and services (US Air Force, 2006).

In terms of services contracts, the 60th CONS manages service contracts that are traditionally found at most Air Force bases. These services include grounds maintenance, food services, custodial, and military family housing maintenance. Due to the unique mobility mission of Travis AFB and the medical mission of the adjacent David Grant Medical Center, the contracting squadron also manages some specialized services contracts such as passenger terminal screening, professional medical staffing services, and falconry services.

2. Services Contracts

Travis AFB contracts with Pride Industries for many labor-intensive service contracts such as grounds maintenance, food services, custodial, and military family housing maintenance. Pride Industries is also the contractor for the passenger terminal operations and pre-board screening. It is “the nation's largest employer of people with disabilities and provides a variety of outsourcing solutions to meet the manufacturing and service needs of companies nationwide” (Pride Industries). These contracts are based on a Firm Fixed-price (FFP) basis and use predominantly detailed specifications. Contracts based on detailed specifications are focused on



the contractor complying with specific government requirements specified in the Statement of Work (SOW).

In supporting the David Grant Medical Center, Travis uses performance-based service contracts for nursing personnel supply, intensive care unit (ICU) services, natal services, and pediatric care. Performance-based service contracts are designed to focus on the desirable performance results, including specific measurable objectives, and quality assurance plan to ensure that contract requirements are met or exceeded (Garrett & Rendon, 2005). Performance-based service contracts are based on a Statement of Objectives (SOO) developed by the government, included in the government's solicitation or Request for Proposal (RFP). The SOO identifies the end-results or desired performance results of the contract.

3. Organizational Processes and Tools

The 60th Contracting Squadron interfaces with the base organizations that own or manage the required service. For example, the 60th Civil Engineering Squadron owns the requirement for the grounds maintenance, custodial, and military family housing maintenance services. The Services Squadron owns the requirement for the food services, and the Medical Center owns the requirement for the medical services. These requirement owners represent the users for these specific services and, thus, are responsible for developing the Statement of Objective (SOO) or Performance Work Statement (PWS), Quality Assurance Surveillance Plan (QASP), and for the actual surveillance of the contractor's performance.

As the organization providing contracts support the requirement owners, the Contracting Squadron meets periodically with the functional managers and QAEs of those organizations to discuss any critical issues that may result in modifications to the contract Statement of Work or Quality Assurance Surveillance Plan. Proactive and frequent communications are essential for a successful services contract.



Travis AFB uses Business Requirement Advisory Groups (BRAGs) as the mechanism for conducting these communications. BRAGs are teams made up of cross-functional personnel that represent the functional organizations involved in the services contracts. These cross-functional teams plan and manage the service contracts throughout the service's lifecycle, including the market research, requirements determination, procurement planning and solicitation planning, as well as determining the performance surveillance strategy for the contract.

Each requirement organization provides Quality Assurance Evaluators (QAEs) for controlling and managing the contractor's performance. The QAEs are considered functional experts within their specific function (grounds maintenance, custodial, housing maintenance, food services, medical services, etc.) and are responsible for ensuring the contractor meets the requirement of the contract. The Contracting Squadron provides training to the QAEs and manages the base-wide Quality Assurance program. The contractor uses the Performance Work Statement to ensure that it meets the performance objectives of the respective Statement of Objective. The Quality Assurance Surveillance Plan provides the Quality Assurance Evaluator with an effective tool for surveying the contractor's performance. These surveillance tools include random sampling, 100-percent inspection, and periodic surveillance (Rendon, 2001). The QASP is used to ensure that the government receives acceptable contractor performance as compared to the technical requirements of the contract.

C. Naval Postgraduate School

The Naval Postgraduate School (NPS) was established in Monterey, CA, in 1952. Along with the US Naval Academy and the Naval War College, NPS is often referred to as one of the Navy's "flagship" educational institutions. NPS awards accredited graduate degrees and offers short courses as well as distance-learning programs. Current full-time enrolment is approximately 1,800. Students are military officers from all five US armed services, US government employees, and officers and government employees from approximately 60 nations.



NPS, like the Presidio of Monterey (POM), faces the challenge of determining the most effective manner in which to organize a complex educational mission while ensuring that adequate support for its physical facilities is in place, including service contracts. Following the closure of the nearby Fort Ord in 1991 (discussed in the previous section on POM), and the near-demise of NPS during the 1995 Defense Base Closure and Realignment (BRAC) process, the School has undergone numerous changes in organizational structure and budgetary responsibilities, which have, in turn, significantly changed how service contracts are defined, competed and administered.

However, NPS and POM have not evolved toward shared support services, with a few minor exceptions such as medical care and military housing. Also unlike POM, NPS has not developed any innovative partnerships with the City of Monterey, although refuse collection and tree-trimming are provided to NPS by the City on a routine contractual basis.

Before the BRAC decision in 2005 to keep NPS open, the School's mission and functions were carried out in an essentially unitary style, much like a typical Air Force Base. Support activities, military personnel and civilian staff were the responsibility of the NPS President and (on a more frequent basis) the Chief of Staff, while the Provost (who is appointed by and responsible to the Secretary of the Navy, not the NPS President) had (and retains) authority over academic matters and faculty personnel issues.

Beginning in 2005, the Navy began to modify its installation management and contracting activities in order to reduce overhead costs and redirect notional savings toward operations. This was primarily achieved by separating mission from support functions, and then transferring responsibility to regional or national organizations that would provide the same services on a consolidated basis, assumedly ensuring a more uniform service level with fewer acquisition and acquisition-related personnel, consolidated service contracts covering a larger number of installations, and with the expectation of lower total contractual expenditures.



The above changes had little impact on service contracting in support of the academic mission, which was left within the purview of NPS. However, the NPS Supply Department was closed and all acquisition above the “micropurchase” (i.e., credit card) limit of \$2500 is now conducted by the Fleet and Industrial Supply Center San Diego (FISC-SD). Purchasing agents in academic departments as well as the NPS Research Office now route their requisitions through FISC-SD, which is responsible for all Navy installations in California and Nevada.

Additionally, support functions such as facilities management and grounds maintenance, police, civilian human resources, legal services and public affairs were transferred from NPS to a new entity, Naval Support Detachment Monterey (NSDM). NSDM functions as a local detachment of the Commander Naval Region Southwest (CNRSW), who is now considered the “landlord” for NPS and all other Navy units in the Monterey area. CNRSW, in turn, reports to the Commander Navy Installations Command (CNIC), a position established to “enable the Navy's Operating Concept through Enterprise alignment of all shore installation support to the Fleet, Fighter and Family” (see http://www.cni.navy.mil/cnic_hq_site/AboutCNIC/index.htm). NSDM has a limited contracting capability, with four contracting officer positions that carry out contracting for the above functions, particularly facilities management and construction. Larger construction contracts are issued by the Naval Facilities Engineering Command Southwest (NAVFAC Southwest) in San Diego, with local inspection and other liaison activities carried out by NSDM personnel, who absorbed the former NPS “Public Works” (facilities and grounds management) role.

In early 2006, further changes were made that added to the fragmentation of service contracting responsibilities in the Monterey area. The remaining supply-related activities under NSDM were transferred to FISC-SD as part of a further regionalization initiative. Similarly, the NSDM Public Works organization became the Monterey detachment of NAVFAC Southwest. Finally, CNRSW currently plans to shift custodial and grounds maintenance contracts from NSDM to NAVFAC



Southwest over the next few years. These are the largest (\$1.2 million and \$614,000 respectively) service contracts now administered by NSDM.

In summary, Navy units in the Monterey area, of which NPS and the Fleet Numerical Meteorological and Oceanographic Center are the largest, are now considered “tenant activities” of their new landlord, CNRSW. Further complexity has been added by centralization of service contracting at FISC-SW and the replacement of the locally managed Public Works functions by NAVFAC detachments.

This challenging mix of organizational structures, comparable in some ways to the one now faced by POM, raises the issue of congruency in managerial decisions, budget allocation, and coherence of support vs. mission needs. A final comment relates to the stewardship of NPS’ academic mission, which has changed from being located in the Office of the Chief of Naval Operations (OPNAV) in Washington to the Naval Education and Training Command in Pensacola, FL, the latter being an organization that administers a large array of training and education facilities and has little expertise in graduate education. Notably, the US Naval Academy is exempt from NETC oversight and continues to report to OPNAV, as did NPS in the past. It should be noted that NETC is currently being restructured and may become integrated into OPNAV. However, NPS appears to lack the clear “mission sponsor” role (which includes significant, dedicated funding) played by the Under Secretary of Defense for Intelligence in the case of the Defense Language Institute, and by extension, POM. How the various Navy and Army organizations in the Monterey area will continue to evolve their reporting relationships and consequent strategy for service contracting remains an open question.



THIS PAGE INTENTIONALLY LEFT BLANK



VI. Conclusions

We want to underscore that this is exploratory research in Service Supply Chain in the Department of Defense. Consequently, the research observations and conclusions listed below are somewhat preliminary in nature, and should be viewed as such.

1. The Department of Defense's services acquisition volume has continued to increase in scope and dollars in the past decade. The GAO found that since FY 1999, the DoD's spending on services has increased by 66%, and in FY 2003, the DoD spent over \$118 billion—or approximately 57% of total DoD procurement dollars—on services (GAO, 2005a). The DoD procures a variety of services, including both the traditional commercial service and services unique to defense. In terms of amount spent, four service categories represent over 50% of total spending on services: (a) professional, administrative, and management support services, (b) construction, repair and maintenance of structure and facilities, (c) equipment maintenance, and (d) information technology services.
2. Presidio of Monterey (POM) has contracted maintenance of about 155 buildings and structures to Presidio Municipal Services Agency (PMSA), a consortium of the cities of Monterey and Seaside. The PMSA agreement has allowed the two cities to apply their expertise to routine municipal services, and the Army to focus on its military mission. Through this partnership and contract with PMSA, the POM has realized a 41% reduction in expenses when compared with previous base operation costs and private contracts. We recommend the DoD explore and evaluate the possibility of establishing such synergistic contractual relations with cities adjacent to other bases in supporting of their respective operations.
3. Proactive and frequent communications are essential for a successful services contract. We found a successful example of this at Travis AFB, where 60th CONS uses BRAGs as the mechanism for conducting such communications. Business Requirement Advisory Groups (BRAGs) are teams made up of cross-functional personnel that represent the functional organizations involved as customers in the services contracts. These cross-functional teams plan and manage the service contracts throughout the service's lifecycle. As the DoD increases the use of centralized contracting organizations and regional contracts, the use of proactive and frequent communications will be



even more essential for the successful management and performance of these contracts.

4. Our visits and interviews at Travis AFB, Presidio of Monterey (POM), and the Naval Support Detachment Monterey (NSDM) confirmed the GAO's finding that, "while the Army's and Navy's creation of centralized installation management agencies can potentially create efficiencies and improve the management of the facilities through streamlining and consolidation, implementation of these plans has so far met with mixed results in quality and level of support provided to activities and installations" (GAO, 2005b).
5. The centralization of contracting offices and use of regional contracts will result in additional dynamics to the DoD's acquisition of services. The use of centralized contracting organizations and regional contracts will require even more proactive and frequent communications between the contracting organization and the customer. Although it is still too early to assess the effectiveness and efficiency of centralized contracting organizations and regional contracts, this research has indicated that centralization and regionalization of services contracts are growing trends in the DoD, and will significantly change how services contracts are managed.
6. Given the unique characteristics of services, such as intangibility, co-production, diversity and complexity, establishing service specifications and measuring and monitoring the quality of delivered service is inherently more complex than that in manufactured goods. Hence, it is critical to have onboard a "knowledgeable client" and the necessary number of skilled contracting personnel to define the requirements and to supervise outsourced services. The DoD has been aggressively complying with OMB's *Circular A-76*, which directs all federal government agencies "to rely on the private sector for needed commercial activities." This has resulted in dramatic growth in the DoD's spending while downsizing the DoD civilian and military acquisition workforce. Although this exploratory study is not yet completed, we believe that the above two trends contradict the critical need to have onboard a necessary number of skilled contracting personnel. This could mean that in the DoD's outsourced services, either the needs are not being fully satisfied, or the value for the money spent is not being realized.
7. Although the DoD acquires more services than goods, and the acquisition of services and the use of service contractors are becoming an increasingly critical aspect of the DoD mission, the management infrastructure for the acquisition of services is less developed than for the acquisition of products and systems. There is a less formal



program management approach and lifecycle methodology for the acquisition of services, which is confirmed by the lack of standardization in the business practices associated with the services acquisition process. This results from the fact that the functional personnel currently managing the services programs are not considered members of the DoD acquisition workforce, and are typically not provided acquisition training under Defense Acquisition Workforce Improvement Act (DAWIA) requirements.

A. Discussion

The establishment of centralized contracting organizations and the use of regional service contracts were identified in this research as a current trend in the DoD's approach to services acquisition. With the drawdown of the defense workforce and the consolidation of military installations, the defense department is attempting to achieve cost efficiencies by centralizing contracting organizations and awarding regional contracts for some base-support services.

An example of a centralized contracting organization includes the Fleet and Industrial Supply Center San Diego (FISCSD). FISC San Diego's regional contracts department provides a full range of acquisition and contracting support to all CONUS Navy installations west of the Mississippi River, unless otherwise assigned (FISC San Diego website). Although the services being acquired are performed at geographically separated locations, in this case CONUS Navy installations west of the Mississippi River, the contracting support for these contracts (Procuring Contracting Officers and contract administrators) are centrally located at FISC San Diego.

An example of a regional service contract includes a single contract awarded by the Air Force Space Command (AFSPC) to Phoenix Management, Inc., for base logistics services at six military installations—Peterson AFB Colorado (including Schriever AFB and Cheyenne Mountain), FE Warren AFB, Wyoming, Malmstrom AFB, Montana, and Vandenberg AFB, California. Although the logistics services will be provided at each of these six locations, only one contract source selection was conducted, and only one contract was awarded by the AFSPC Headquarters



contracting office. It is also assumed that this logistics services contract will be centrally controlled at AFSPC Headquarters, but de-centrally executed at each of the military installations (Phoenix Management, Inc., website)

The centralization of contracting offices and use of regional contracts will result in additional dynamics to the acquisition of services. The advantages of centralized contracting offices include better control of contracting operations, the development of consistent and standardized services requirements, and a decreased contract-management workforce. Disadvantages of centralized contracting organizations include physical separation from the customer and the potential of being non-responsive to the customer's requirements. For example, if the commander of a military installation has concerns or issues with the quality of the contractor's performance, the commander will typically have to contact the contracting organization—which is not only geographically separated from the commander's installation, but may not consider the contractor's performance a critical priority.

The use of regional contracts provides the contracting organization with a means of applying a strategic approach to the acquisition of services. The advantages of regional contracts include ensuring and maintaining standardized services requirements at multiple military installations, leveraging the buying power of the buying organization, and reducing the number of contracts and contractors managed by the contracting organization. The disadvantages of regionalized contracts include contracts that do not address the unique needs of each of the military installations. For example, a regional grounds maintenance contract may not meet the unique mission needs of a military installation with flight operations if the other military installations under that contract do not have a flight-operations mission. Another example would be a regional custodial services contract for a group of military installations, some with 24-hour flight or training operations and others with more traditional working hours.



References

- Abramson, M.A., & Harris, R.S. III. (2003). The transformation of government procurement. In M.A Abramson & R.S. Harris, III (Eds.), *The procurement revolution* (pp. 3-11). Lanham, MD: Rowman & Littlefield Publishers.
- Apte, U. M., & Mason, R.O. (1995). Global disaggregation of information-intensive services. *Management Science*, 41(7), 1250-1262.
- Apte, U. M., Karmarkar, U. S., & Pitbladdo, R. (1996). Quality management in services: Analysis and applications. In P. Lederer, & U. Karmarkar (Eds.), *Practice of quality management*. Boston, MA: Harvard Business School Press.
- Auernig, M. Director of Contracting, Presidio of Monterey. Personal interview (2006).
- Ausink, J., Camm, F., & Cannon, C. (2001). *Performance-based contracting in the Air Force: A report on experiences in the field* (DB-342-AF). Santa Monica, CA: RAND.
- Baldwin, L. H., & Hunter, S. (2004). *Defining needs and managing performance of installation support contracts: Perspectives from the commercial sector* (MR-1812). Santa Monica, CA: RAND.
- Bowen, D. E., Chase, R.B., & Cummings, T.G. (1990). *Service management effectiveness*. San Francisco, CA: Jossey-Bass Inc.
- Brown, S. W., Gummesson, E., Edvardsson, B., & Gustavsson, B. (1991). *Service quality*. Lexington, MA: Lexington Books.
- Buzzell, R. D., & Gale, B.T. (1987). *The PIMS principle: Linking strategy to performance*. New York: The Free Press.
- Cairns, J. (2005, December 1). *US Army Garrison—Presidio of Monterey* (IMSW-POM-ZA). PowerPoint Presentation.
- Camm, F. I., Blickstein, & Venzor, J. (2004). *Recent large service acquisitions in the Department of Defense*. Santa Monica, CA: RAND National Defense Research Institute.
- Chase, R. (1981). The customer contact approach to services: Theoretical bases and practical extensions. *Operations Research*, 21(4), 698-705.



- Chase, R. B., & Bowen, D.E. (1991). Service quality and the service delivery system: A diagnostic framework. In S.W. Brown, E. Gummesson, B. Edvardsson, & B. Gustavsson (Eds.). *Service quality* (pp.157-176). Lexington, MA: Lexington Books.
- Collier, D. A. (1990). Measuring and managing service quality. In D.E. Bowen, R.B. Chase, & T.G. Cummings (Eds.), *Service management effectiveness* (pp. 234-265). San Francisco, CA: Jossey-Bass.
- Commander, Navy Installations. Retrieved from http://www.cni.navy.mil/cnic_hq_site/AboutCNIC/index.htm
- Crosby, P. B. (1979). *Quality is free*. New York: McGraw-Hill.
- Deming, W. E. (1985). *Out of crisis*. Cambridge, MA: MIT, Center for Advanced Engineering Study.
- Denhardt, K. G. (2003). The procurement partnership model: Moving to a team-based approach. In M.A. Abramson & R.S. Harris, III (Eds.), *The procurement revolution* (pp. 59-86). Lanham, MD: Rowman & Littlefield Publishers.
- Defense Language Institute Foreign Language Center, US Department of the Army. (2006). *History of DLI*. Retrieved March 30, 2006, from http://www.dliflc.edu/about_dliflc.
- Defense Language Institute Foreign Language Center, US Department of the Army. (2006). *Partnerships: Base operations support*. Retrieved March 31, 2006, from <http://www.dli.army.mil/partnerships/baseops.htm>.
- Department of Defense Office of the Inspector General. (2001, March 29). *Statement of Robert J. Lieberman, Deputy Inspector General, Department of Defense, to the Senate Subcommittee on Oversight of Government Management, Restructuring and The District of Columbia and the House Subcommittee on Civil Service and Agency Organization on national security implications of the human capital crisis* (D-2001-091). Washington, DC: author.
- Department of Defense Office of the Inspector General. (2003). *Acquisition: Contracts for professional, administrative and management support services* (D-2005-015). Washington, DC: author.
- Department of Defense Office of the Inspector General. (2005). *Contract surveillance for service contracts* (D-2006-010). Washington, DC: author.



Department of Toxic Substances Control. State of California. (2006). EnviroStor Database: Fort Ord, CA. Retrieved March 30, 2006, from <http://www.envirostor.dtsc.ca.gov>.

Federal Acquisition Council. (2006). *Federal acquisition regulation*. Part 37: Services contracting. Retrieved March 27, 2006, from <http://farsite.hill.af.mil>.

Federal Procurement Data System-Next Generation (FPDS-NG). (2004). *Cadenza Document: FY 2004 Federal Awards by Department*. Retrieved from http://www.fpdsng.com/downloads/top_requests/total_federal_spending_by_dept.pdf

FISC San Diego website, <https://www.navsup.navy.mil>

Fitzsimmons, J. A., & Fitzsimmons, M.J. (2006). *Service management: Operations, strategy, and information technology* (5th ed.). New York: McGraw-Hill.

Gansler, J.S. (2003). A vision of the government as a world-class buyer: Major procurement issues for the coming decade. In M.A. Abramson, R.S. Harris, III (Eds.), *The procurement revolution* (pp. 13-57). Lanham, MD: Rowman & Littlefield Publishers

GAO. US Government Accountability Office. (2001a). *Contract management: Improving services acquisitions* (GAO-02-179T). Washington, DC: author.

GAO. US Government Accountability Office. (2001b). *Contract management: Trends and challenges in acquiring services* (GAO-01-753T). Washington, DC: author.

GAO. US Government Accountability Office. (2002a). *Best practices: taking a strategic approach could improve DoD's acquisition of services* (GAO-02-230). Washington, DC: author.

GAO. US Government Accountability Office. (2002b). *Commercial activities panel: Improving the sourcing decisions of the government* (GAO-02-2xx). Washington, DC: author.

GAO. US Government Accountability Office. (2003a). *Best practices: Improved knowledge of DoD service contracts could reveal significant savings* (GAO-03-661). Washington, DC: author.

GAO. US Government Accountability Office. (2003b). *Contract management: High level attention needed to transform DoD services acquisition* (GAO-03-935). Washington, DC: author.



- GAO. US Government Accountability Office. (2005a). *Contract management: opportunities to improve surveillance on Department of Defense contracts* (GAO-05-274). Washington, DC: author.
- GAO. US Government Accountability Office. (2005b). *Defense infrastructure: Issues need to be addressed in managing and funding base operations and facilities support* (GAO-05-556). Washington, DC: author.
- GAO. US Government Accountability Office. (2005c). *Framework for assessing the acquisition function at federal agencies* (GAO-05-218G). Washington, DC: author.
- GAO. US Government Accountability Office. (2005d). *High risk series: An update* (GAO-05-207). Washington, DC: author.
- GAO. US Government Accountability Office. (2005e). *Human capital: Agencies need leadership and the supporting infrastructure to take advantage of new flexibilities* (GAO-05-616T). Washington, DC: author.
- GAO. US Government Accountability Office. (2006). *Rebuilding Iraq: Stabilization, reconstruction and financing challenges* (GAO-06-428T). Washington, DC: author.
- Garrett, G.A., & Rendon, R.G. (2005). *Contract management: Organizational assessment tools*. National Contract Management Association, McLean, VA.
- Gronroos, C. (1982). *Strategic management and marketing in the service sector*. Helsingfors, Sweden: Swedish School of Economics and Business.
- Hanks, C.H., Axelband, E.I., Lindsay, S., Malik, M.R., Steele, B.D. (2005). *Reexamining military acquisition reform: Are we there yet?* (MG-291). Santa Monica, CA: RAND.
- Heskett, J. L., Sasser, W.E., & Hart, C.W.L. (1990). *Service breakthroughs: Changing the rules of the game*. New York: The Free Press.
- Howe, K. (2006, January 22). Money talks at language school: \$362 million will help hire teachers, add languages to DLI program. *Monterey County Herald*. Retrieved from LexisNexis, January 22, 2006.
- Karmarkar, U. S., & Pitbladdo, R. (1992). *Quality, class and competition*. Simon working paper.
- Karmarkar, U. S., & Pitbladdo, R. (1995). Service markets and competition. *Journal of Operations Management*, 12(3-4), 397-411.



- Levy, D.G., Moini, J.S., Kaganoff, T., Keating, E.G., Augustine, C.H., Bikson, T. K., Leuschner, K.J., Gates, S.M. (2004). *Base realignment and closure (BRAC) and organizational restructuring in the DoD: Implications for education and training and infrastructure* (MG-153). Santa Monica, CA: RAND, p. 36-50.
- Lovelock, C. H. (1983, Summer). Classifying services to gain strategic marketing advantage. *Journal of Marketing*, 47(Summer), 9-20.
- Lovelock, C. H. (1992). A basic toolkit for service managers. In C. H. Lovelock (Ed.). *Managing services: Marketing, operations and human resources* (2nd ed) (pp.17-30). Englewood Cliffs, NJ: Prentice Hall.
- Lovelock, C. H. (1992). *Managing services: Marketing, operations and human resources* (2nd ed.). Englewood Cliffs, NJ: Prentice Hall.
- McLaughlin, C. P., & Coffey S. (1990). Measuring productivity in services. *International Journal of Service Industries Management*, 1, 46-64.
- Murdick, R. G., Render, B., & Russell, R.S. (1990). *Service operations management*. Needham Heights, MA: Allyn and Bacon.
- Nonaka, I., & Takeuchi, H. (1995). *The knowledge-creating company: How Japanese companies create the dynamics of innovation*. New York: Oxford University Press USA, p. 12.
- OMB, Executive Office of the President. (2003). *Performance of commercial activities* (Circular No. A-76 (REVISED)).
- Parasuraman, A., Zeithaml, V.A., & Berry, L.L. (1985, Fall). A conceptual model of service quality and its implications for future research. *Journal of Marketing*, 49(Fall), 41-50.
- Phoenix Management, Inc., website. Retrieved from <http://www.pmiaus.com>
- Pride Industries website, retrieved March 30, 2006 from <http://www.prideindustries.com/>.
- Presidio of Monterey, US Department of the Army. (2004, January 24). *Presidio of Monterey municipal services contract*. Information Paper (ATZP-GC).
- Presidio of Monterey, Office of the Command Historian, US Department of the Army. (2006). *Presidio of Monterey [history of]*. Retrieved March 30, 2006, from <http://monterey.army.mil>.
- Quinn, J. B. (1992). *Intelligent enterprise: A knowledge and service based paradigm for industry*. New York The Free Press.



- Rendon, R.G. (2001). Outsourcing base operations support functions. *Program Manager*, Defense Acquisition University Press.
- Rendon, R.G. (2005, Summer). Commodity sourcing strategies: Processes, best practices, and defense initiatives. *Journal of Contract Management*, 3(1), 7.
- Sasser, W. E., Olsen, R. P. & Wyckoff, D. D. (1978). *Management of service operations: Text, cases, and readings*. Boston, MA: Allyn & Bacon.
- Sasser, W. E., Hart, C. W. L., & Heskett, J. L. (1991). *The service management course*. New York: The Free Press.
- Schmenner, R. W. (1986, Spring). How can service businesses survive and prosper? *Sloan Management Review*, (Spring), 21-32.
- Stanberry, S.A. (2001). *Federal contracting made easy*. Vienna, VA: Management Concepts.
- US Air Force. (2005). *Air Force Instruction. Acquisition: Performance based services acquisition (PBSA) (63-124)*.
- US Air Force. (2006). *60th Contracting Squadron mission overview*. Travis AFB.
- Uslar, H. (2005). *The Monterey model: Monterey's municipal-military partnership with the Department of the Army*. PowerPoint Presentation by the Deputy Public Works Director, City of Monterey, to the 2005 Annual Conference of the Association of Defense Communities, Denver, June 4-7. Retrieved April 3, 2006, from <http://www.defensecommunities.org>.
- Williamson, O. E. (1983). *Markets and hierarchies: Analysis and antitrust implications*. New York: The Free Press.
- Witte, G. (2005, October 29). Suspected illegal workers detained at US bases: Investigators question employees doing contract work at military facilities. *The Washington Post*, p. A5.
- Zeithaml, V. A., Parasuraman, A., & Berry, L. L. (1990). *Delivering quality service*. New York: The Free Press.



Initial Distribution List

1. Defense Technical Information Center 2
8725 John J. Kingman Rd., STE 0944; Ft. Belvoir, VA 22060-6218
2. Dudley Knox Library, Code 013 2
Naval Postgraduate School, Monterey, CA 93943-5100
3. Research Office, Code 09 1
Naval Postgraduate School, Monterey, CA 93943-5138
4. Robert N. Beck 1
Dean, GSBPP
555 Dyer Road, Naval Postgraduate School, Monterey, CA 93943-5000
5. Keith F. Snider 1
Associate Professor, GB
555 Dyer Road, Naval Postgraduate School, Monterey, CA 93943-5000
6. James B. Greene 1
Acquisition Chair, GB
555 Dyer Road, Naval Postgraduate School, Monterey, CA 93943-5000
7. Bill Gates 1
Associate Dean for Research, GB
555 Dyer Road, Naval Postgraduate School, Monterey, CA 93943-5000
8. Uday Apte 1
Professor, GB
555 Dyer Road, Naval Postgraduate School, Monterey, CA 93943-5000
9. Geraldo Ferrer 1
Associate Professor, GB
555 Dyer Road, Naval Postgraduate School, Monterey, CA 93943-5000
10. Ira Lewis 1
Associate Professor, GB
555 Dyer Road, Naval Postgraduate School, Monterey, CA 93943-5000
11. Rene Rendon 1
Senior Lecturer, GB
555 Dyer Road, Naval Postgraduate School, Monterey, CA 93943-5000



12. Karey L. Shaffer

1

Program Manager, Acquisition Research Program, GB
555 Dyer Road, Naval Postgraduate School, Monterey, CA 93943-5000

Copies of the Acquisition Sponsored Research Reports may be printed from our website www.acquisitionresearch.org



2003 - 2006 Sponsored Acquisition Research Topics

Acquisition Management

- Software Requirements for OA
- Managing Services Supply Chain
- Acquiring Combat Capability via Public-Private Partnerships (PPPs)
- Knowledge Value Added (KVA) + Real Options (RO) Applied to Shipyard Planning Processes
- Portfolio Optimization via KVA + RO
- MOSA Contracting Implications
- Strategy for Defense Acquisition Research
- Spiral Development
- BCA: Contractor vs. Organic Growth

Contract Management

- USAF IT Commodity Council
- Contractors in 21st Century Combat Zone
- Joint Contingency Contracting
- Navy Contract Writing Guide
- Commodity Sourcing Strategies
- Past Performance in Source Selection
- USMC Contingency Contracting
- Transforming DoD Contract Closeout
- Model for Optimizing Contingency Contracting Planning and Execution

Financial Management

- PPPs and Government Financing
- Energy Saving Contracts/DoD Mobile Assets
- Capital Budgeting for DoD
- Financing DoD Budget via PPPs
- ROI of Information Warfare Systems



- Acquisitions via leasing: MPS case
- Special Termination Liability in MDAPs

Logistics Management

- R-TOC Aegis Microwave Power Tubes
- Privatization-NOSL/NAWCI
- Army LOG MOD
- PBL (4)
- Contractors Supporting Military Operations
- RFID (4)
- Strategic Sourcing
- ASDS Product Support Analysis
- Analysis of LAV Depot Maintenance
- Diffusion/Variability on Vendor Performance Evaluation
- Optimizing CIWS Life Cycle Support (LCS)

Program Management

- Building Collaborative Capacity
- Knowledge, Responsibilities and Decision Rights in MDAPs
- KVA Applied to Aegis and SSDS
- Business Process Reengineering (BPR) for LCS Mission Module Acquisition
- Terminating Your Own Program
- Collaborative IT Tools Leveraging Competence

A complete listing and electronic copies of published research within the Acquisition Research Program are available on our website: www.acquisitionresearch.org



ACQUISITION RESEARCH PROGRAM
GRADUATE SCHOOL OF BUSINESS & PUBLIC POLICY
NAVAL POSTGRADUATE SCHOOL



ACQUISITION RESEARCH PROGRAM
GRADUATE SCHOOL OF BUSINESS & PUBLIC POLICY
NAVAL POSTGRADUATE SCHOOL
555 DYER ROAD, INGERSOLL HALL
MONTEREY, CALIFORNIA 93943

www.acquisitionresearch.org